



3 Series 1 Series Heated Cabinets

INSTRUCTIONS FOR USE



3 Series



1 Series

Differences on voltage, amps or wattage are listed with bold text in replacement part descriptions.

This manual covers both 120V and 220-240V cabinets, confirm voltage before selecting and ordering parts.

Metro Heated Cabinets are for Hot Food Holding applications only



We put space to work.™

InterMetro Industries Corporation
Wilkes-Barre, PA 18705
1-800-992-1776 www.metro.com

METRO[®]**3 & 1 SERIES****BASIC OPERATING GUIDELINES****BASIC CABINET SETUP**

- A. Refer to DATA PLATE for electrical requirements. Cabinets rated at 120V 1440W must be plugged into either a 15 amp or 20 amp 125VAC receptacle. Cabinets rated at 120V 2000W must be plugged into a 20 amp 125VAC receptacle. Cabinets rated at 220-240V must be plugged into a 15 amp 250VAC receptacle.
- B. With POWER switch OFF, plug into VAC grounded receptacle.
- C. Fill stainless water pan to top with clean HOT tap water for Proofing or if moisture is desired for Holding. Check water level every 3 hours (2 hours when Proofing) and refill with clean HOT tap water as necessary. Water pan does not have to be filled for Holding. Proofing requires water pan to be filled.

HOLDING INSTRUCTIONS (Holding, Combo, Moisture Holding)

- 1) Set Combination Module switch to HOLD.
- 2) Set POWER switch to the ON position.
- 3) Set TEMPERATURE control to 10.
- 4) Moisture Module Only: Set MOISTURE control to 10 (or desired level).
- 5) Pre-heat cabinet until desired temperature is reached (typical heat-up time from 72°(22°C) ambient to 160°(71°C) is approximately 45 minutes).
- 6) Re-set TEMPERATURE control and adjust as necessary to reach desired temperature - setting 6-8 is typical for 150°(66°C) to 160° (71°C). Indicator light will turn on and off as the heat thermostat cycles.

PROOFING INSTRUCTIONS (Combo and Proofing)

- 1) Set Combination Module switch to PROOF.
- 2) Set POWER switch to the ON position.
- 3) Set TEMPERATURE control to 2.
- 4) Set MOISTURE control to 10.
- 5) Pre-heat cabinet until desired temperature and humidity is reached (typical heat-up time from 72°(22°C) ambient to 95°(35°C) and 95% relative humidity is approximately 30 minutes).
- 6) Adjust settings as necessary to reach desired temperature and humidity levels. Power indicator lights will turn on and off as the heat and moisture thermostats cycle.

**CAUTION**

- STAINLESS WATER PAN MUST BE PLACED INSIDE CABINET DURING MODULE OPERATION. PLASTIC DRIP PAN MUST BE PLACED UNDER THE FRONT BUMPER DRIP TROUGH OF THE CABINET.
- UNPLUG CABINET FROM WALL AND ALLOW CABINET (AND WATER) TO COOL BEFORE CLEANING OR SERVICING.
- DO NOT SPRAY OR POUR WATER ON THE MODULE WHEN CLEANING AND DO NOT IMMERSE THE MODULE IN WATER. WIPE WITH A DAMP CLOTH AND DRY WITH A TOWEL.
- KEEP CABINET AND MODULE CLEAN. ACCUMULATION OF GREASE AND OTHER DRIPPINGS MAY IGNITE.

TABLE OF CONTENTS

SECTION	PAGE
I. Basic Operating Guidelines.....	Inside Front Cover
II. Safety Instructions.....	1
III. Identifying Your Cabinet.....	2
IV. Installation & Set-up.....	3
V. Product Features.....	7
VI. Operating Instructions.....	8
VII. Care & Maintenance.....	10
VIII. Basic Troubleshooting.....	11
IX. Service & Replacement Parts.....	13
X. Warranty.....	26

SAFETY INFORMATION

WARNING: Follow all food safety guidelines. Pre-heat the cabinet to the desired temperature before placing cooked, hot food into the cabinet. This is not a re-thermalizing cabinet. Food must be at the appropriate temperature before being placed into this cabinet. Use a food probe to check internal food temperature — the cabinet temperature is not necessarily the internal food temperature.

WARNING: Only factory-approved service agents should attempt to service, repair or replace electrical components, wiring or power cord.

WARNING: Unplug the cabinet before cleaning or servicing. Do not wash the cabinet with a water jet or high pressure water.

WARNING: This cabinet is for hot food holding applications only.

CAUTION: Stainless steel water pan and Plastic drip pan should not go together when operating the cabinet. Stainless steel water pan is located/installed inside cabinet and plastic drip pan is located/installed underneath the cabinet.

CAUTION: Do not spray or pour water into the module. To clean the cabinet, wipe with a damp cloth and dry with a towel. Use only cleaning agents approved for aluminum.

CAUTION: Water dripping onto the floor from open doors can be a slip hazard.



IDENTIFYING YOUR CABINET

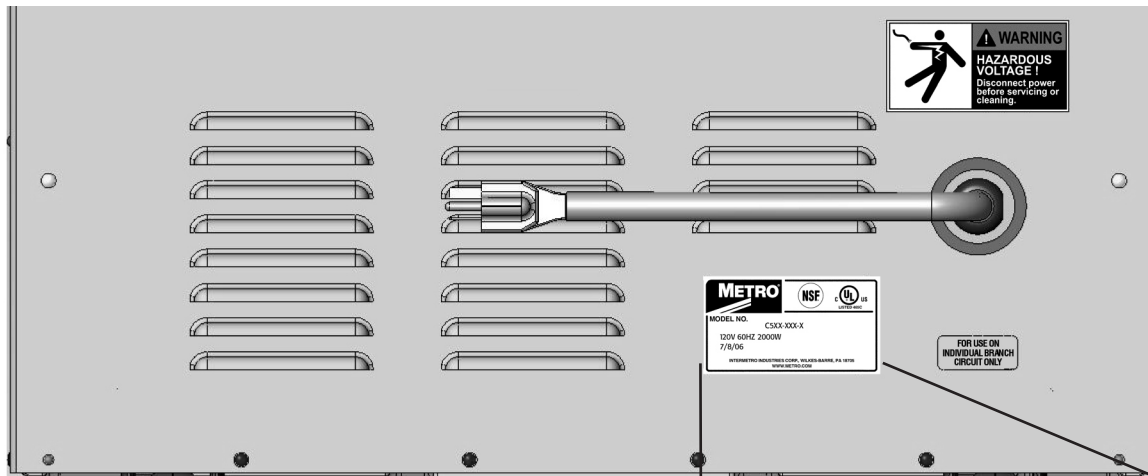

For future reference, record the cabinet model number & manufactured date found on the date plate located at rear of cabinet. Also record the module serial number located inside the cabinet on module right-hand corner.

Model number: _____

Cabinet manufactured date: _____

Module serial number: _____

Module manufactured date: _____

Fill out and return the warranty card located at the back of this manual.



PART NUMBERING

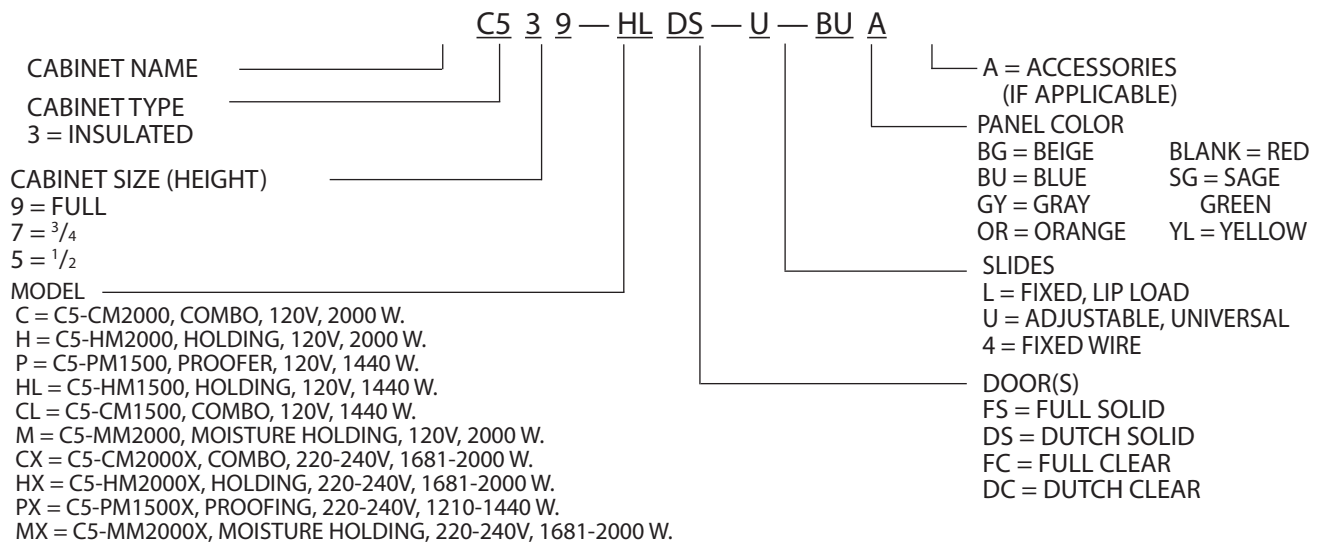
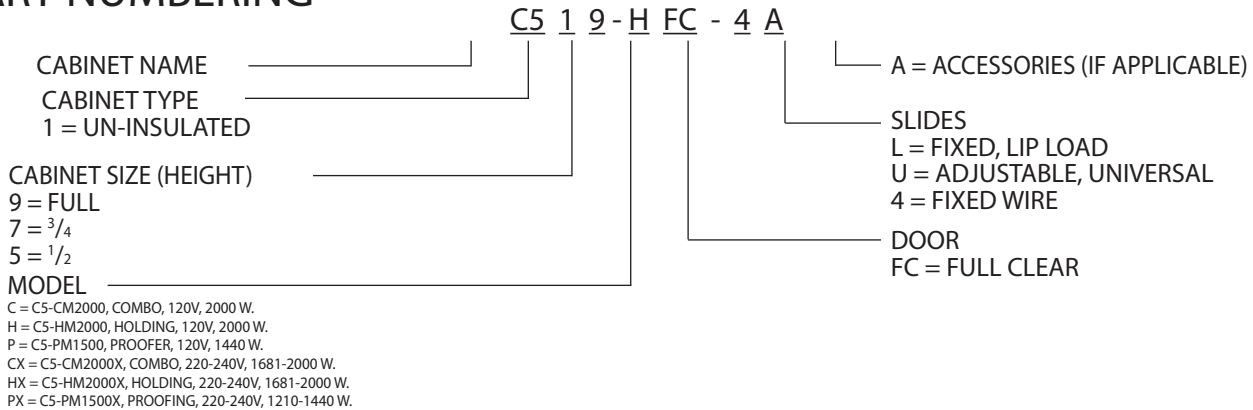

MODULE SERIAL NUMBER LABEL

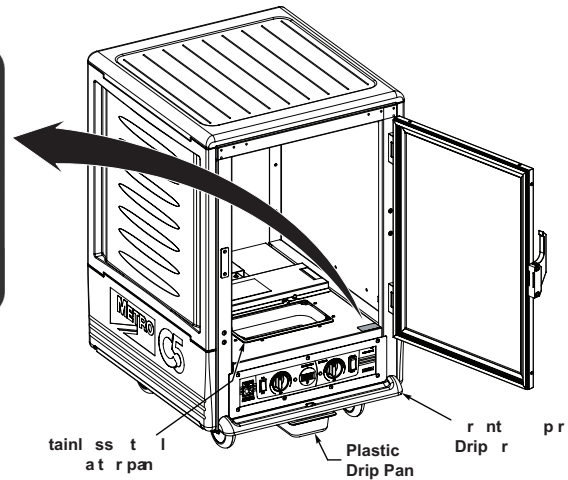
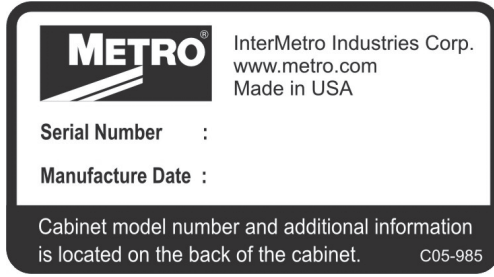

INSTALLATION AND SET-UP

1. Check for Shipping Damage: Check the packaging and cabinet for shipping damage after unloading the unit, and after removing all the packaging.
2. The receiver of this product is responsible for filing freight damage claims. This equipment must be opened immediately for inspection. All visible damage must be reported to the freight company within 48 hours and must be noted on freight bill at the time of delivery.
3. Concealed damage is your responsibility — you must advise the carrier of any loss or damage within 15 days after receipt of the cabinet. If there is damage, retain the original packaging for inspectors.
4. After unpacking the cabinet, remove all tape and packing material from the inside as well as outside of the unit.

Note: Plastic drip pan is wrapped and placed inside the cabinet while packaging. Plastic drip pan must be installed underneath the cabinet.

5. Any protective covers (plastic or paper sheet) on the sheet metal or clear door, if applicable, must also be removed before turning the cabinet on.

Warning: Only factory-approved service agents should attempt to service, repair or replace electrical components, wiring or the power cord.

6. Refer to the data plate located near the power cord for the electrical specifications of cabinet as shown below.
 - With the POWER switch OFF, plug the cord into the appropriate rated, grounded receptacle.
 - Cabinets rated at 120V 1440W must be plugged into either a 15 amp or 20 amp 125VAC receptacle.
 - Cabinets rated at 120V 2000W must be plugged into a 20 amp 125VAC receptacle.
 - Cabinets rated at 220-240V must be plugged into a 15 amp 250VAC receptacle.

15 Amp Outlet
For 120V 1440 Watt Cabinets

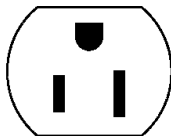

20 Amp Outlet
For 120V 2000 Watt Cabinets

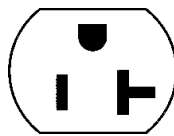

250 VAC 15 Amp Outlet
(For All 220-240V Cabinets)

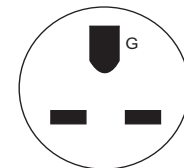

(1440 watt cabinets can be plugged into 20 Amp outlet)

Warning: A 3 Series cabinet (polymer Insulation Armour panels on the sides, top and rear) must not be placed next to char broilers. Allow 18" (46cm) between the Insulation Armour and any cooking equipment. Do not allow hot kitchen equipment whose surfaces exceed 200°F (90°C) to touch the panels.

Warning: Do not allow combustible materials to be stored or accumulate on, under or next to the cabinet. Do not block any ventilation louvers or slots.

Note: For 120V units temperature is displayed °F.
For 220-240V units temperature is displayed in °C.

INSTALLATION AND SET-UP (continued)

SLIDE INSTALLATION

The universal rack uprights or lip load slides have been installed at the factory. If removed for cleaning, reinstall by hanging them on the shoulder rivets on the side walls of the cabinet.

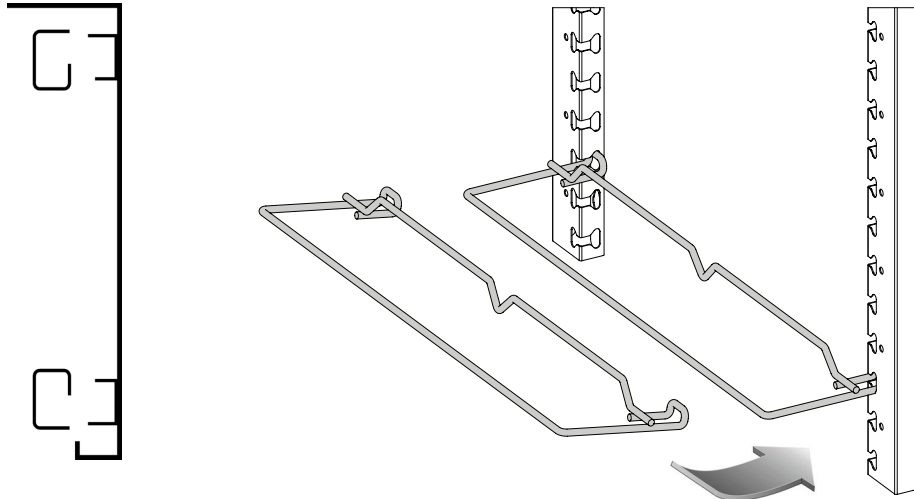

TOP VIEW

SLIDE POSITION TO MAXIMIZE 3" PAN CAPACITY OF UNIVERSAL SLIDES

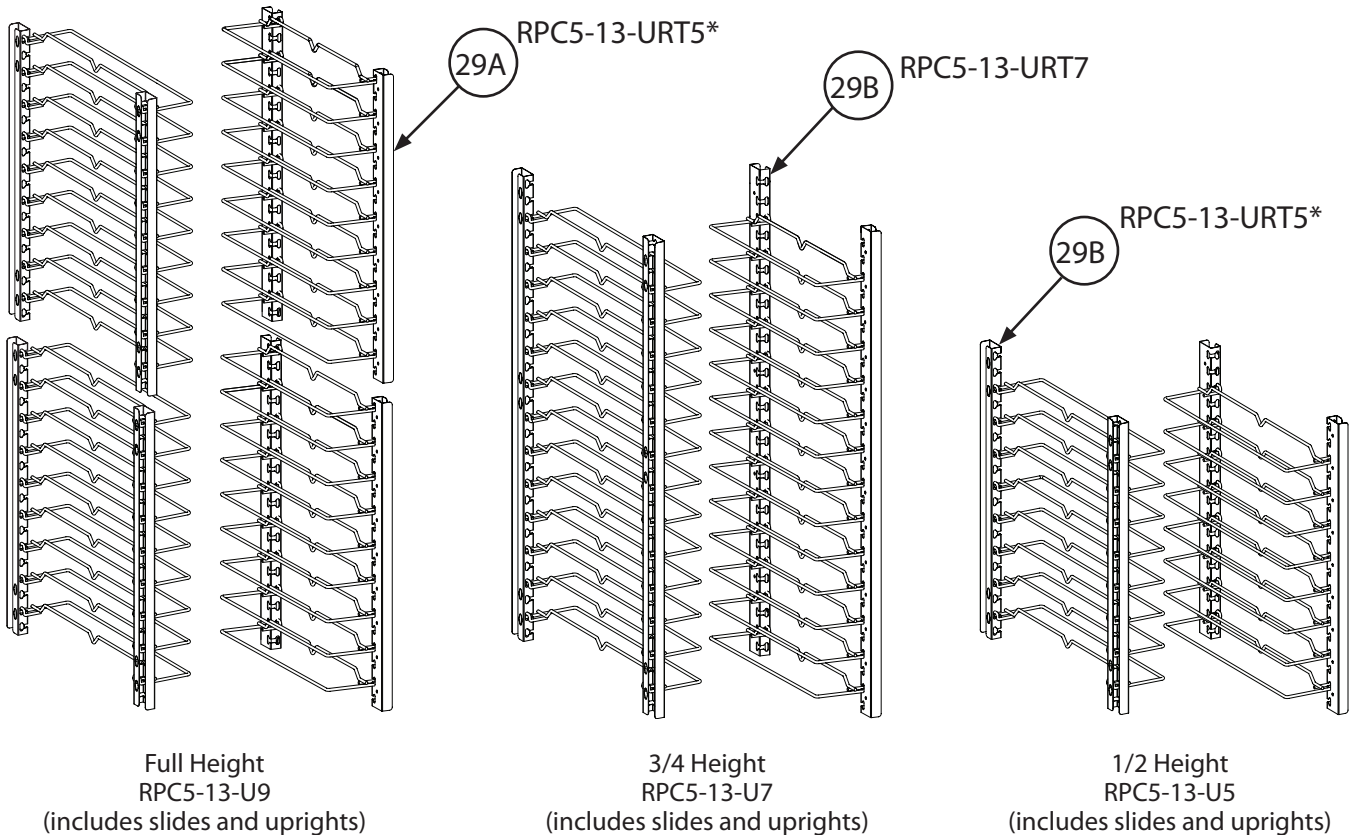

Slides sold in pairs. For additional pair of wire slides, order C5-USLIDEPR-C for Chrome or C5-USLIDEPR-S for Stainless Steel. To order individual universal uprights only, see item #'s 29A, 29B.

INSTALLATION AND SET-UP (continued)

CORRECT ORIENTATION OF LIP LOADED SLIDE RACKS

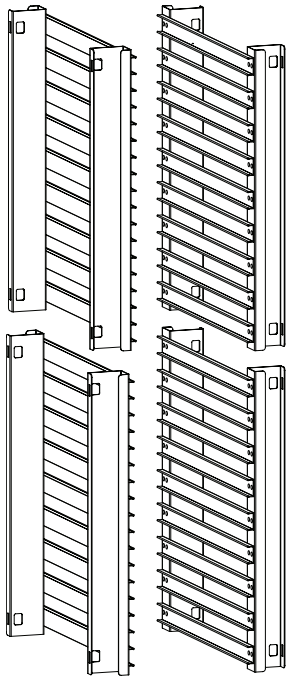

Full Height
2-piece Construction
Part No: C5-13-L9D
(For Dutch Door Units)

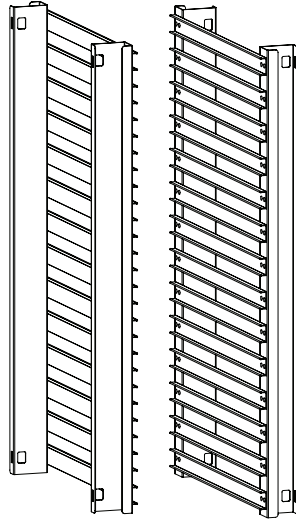

3/4 Height
1-piece Construction
Part No: C5-13-L-7

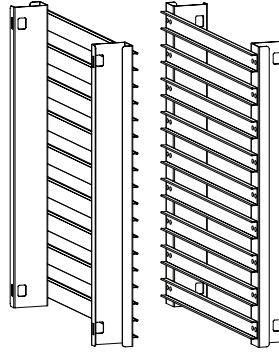

1/2 Height
1-piece Construction
Part No: C5-13-L5

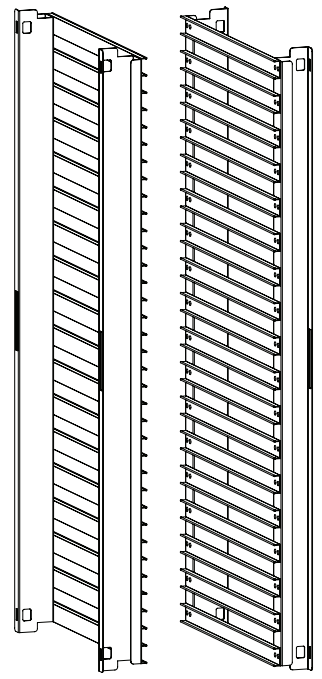

Full Height
1-piece Construction
Part No: C5-13-L9F
(For Full Height Door Units)

CORRECT ORIENTATION OF FIXED WIRE SLIDES

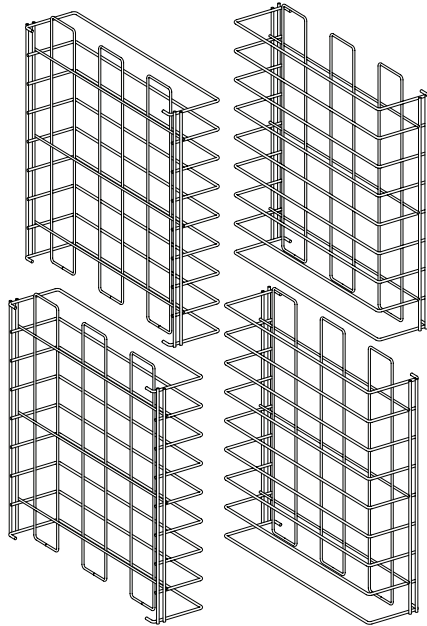

Full Height
Part No: C5-13-FW-9

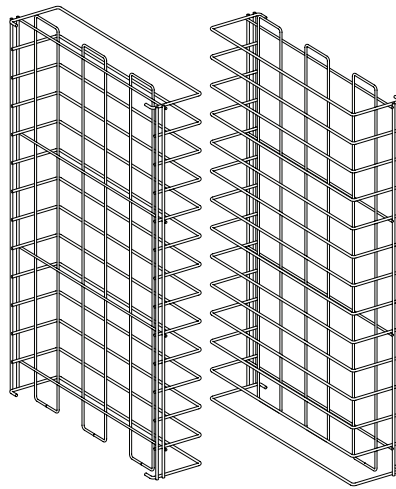

3/4 Height
Part No: C5-13-FW-7

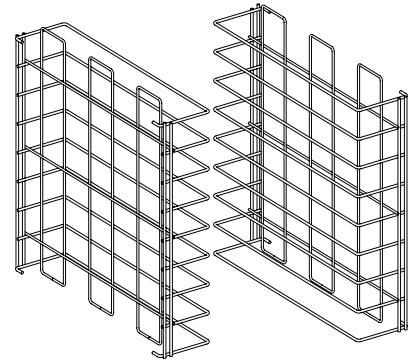

1/2 Height
Part No: C5-13-FW-5

REVERSING THE DOORS

The door on your cabinet can be reversed to accommodate a right- or left-hand opening. The cabinet has been shipped with the hinges mounted on the right-hand side. To reverse, follow the instructions listed below:

1. With the door in the closed position, remove the hinge pin by driving it out using a hammer and a drive pin or small diameter screwdriver.
2. Once the pins are removed grasp the door firmly and pull the latch lever, this will release the door. Set the door aside being careful not to damage the gasket.
3. Remove the screws from the left side of the cabinet and set aside. Then remove the cabinet mounted part of the hinge and remount to the left side of the cabinet. Put the screws removed from the left side of the cabinet into the remaining holes on the right side of the cabinet. Tighten all screws before proceeding.
4. Relocate the latch plate(s) from the left side to the right by removing the two mounting screws. Tighten all screws before proceeding.
5. Rotate the door 180 degrees and align the door mounted hinge part with the cabinet mounted hinge part and tap the hinge pin into place so the top of the pin is flush with top of the cabinet mounted hinge part. Invert the door latch by removing the black plastic screw covers and remove the screws holding the latch in place.

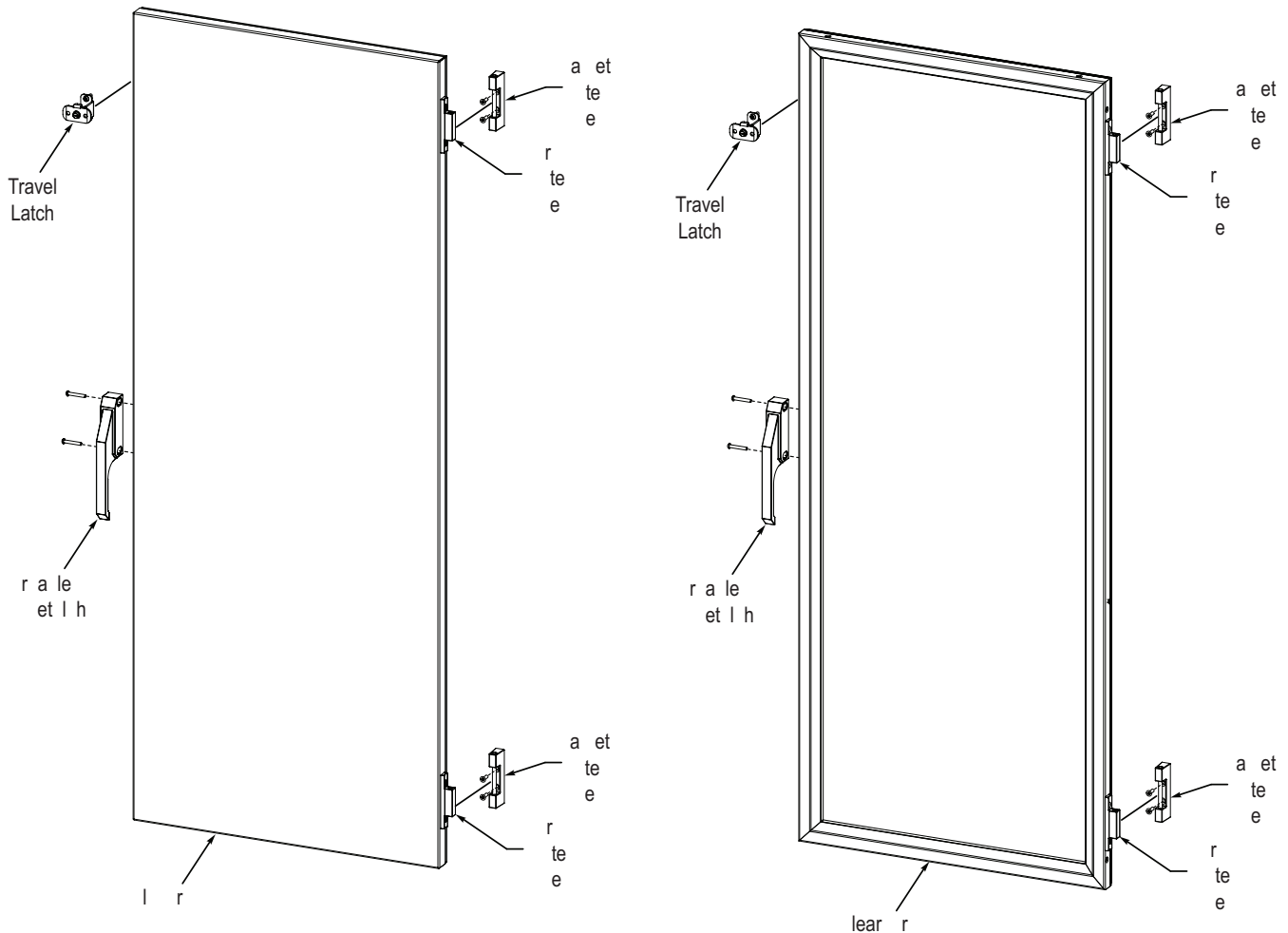

PRODUCT FEATURES

- The module has been placed at the base of the cabinet for easy accessibility and efficient operation.
- Clearly-marked control panel for easy viewing allows climate adjustments without opening the door.
- Removable stainless steel water pan (located inside cabinet).
- Cabinet designed with plastic drip pan (located underneath cabinet) to contain condensation drippage.
- Field reversible, gasketed door.
- Easy pull adjustable magnetic door latch.
- Cord keeper at rear of cabinet.
- All components — door, module, slide racks — are removable to permit thorough, obstruction-free cleaning.

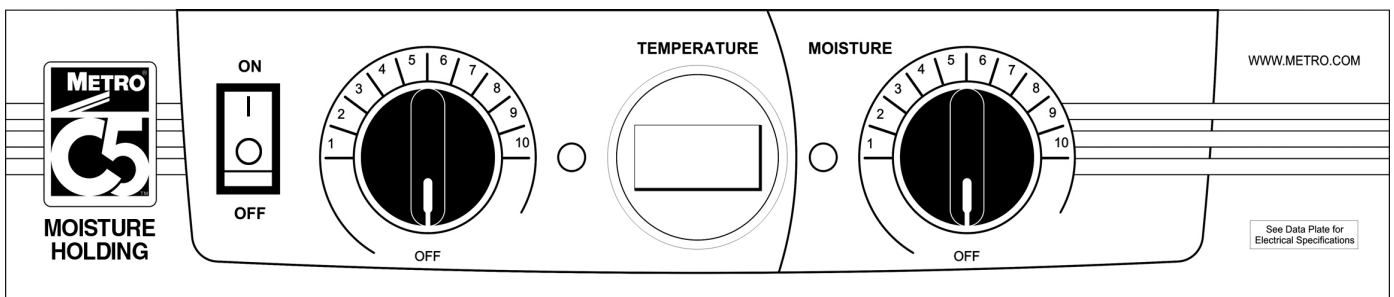
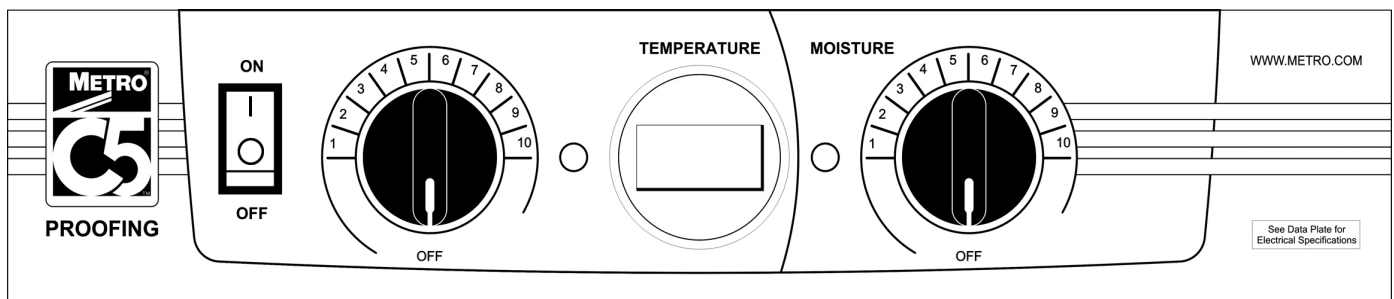
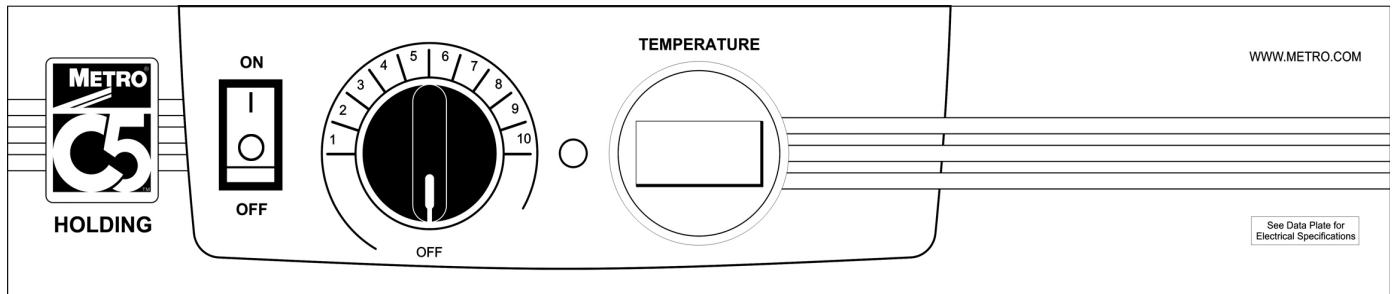
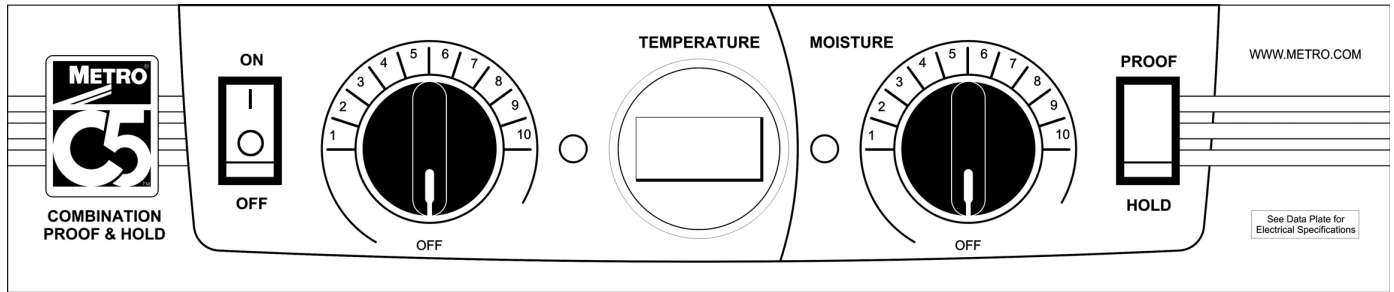
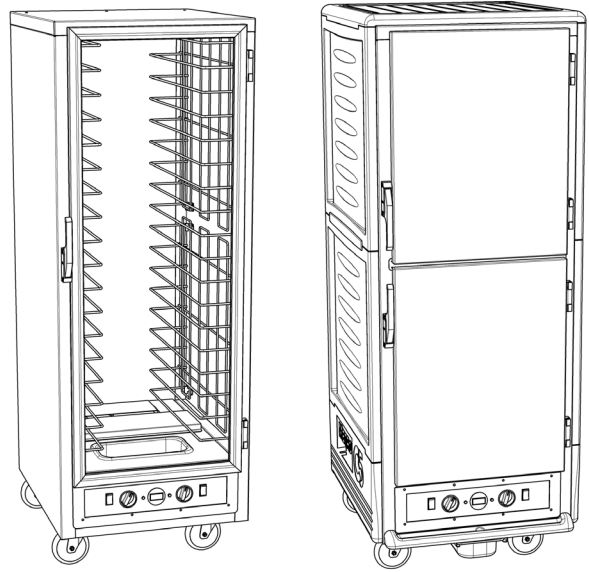

OPERATING INSTRUCTIONS

Power-Up & Pre-Heat

YOUR C5 1 SERIES OR 3 SERIES CABINET MAY BE EQUIPPED WITH SEVERAL DIFFERENT MODULES:

C5 1 SERIES

COMBINATION PROOF & HOLD MODULE
HOLDING MODULE
PROOFING MODULE

C5 3 SERIES

COMBINATION PROOF & HOLD MODULE
HOLDING MODULE
MOISTURE HOLDING MODULE

- A. Refer to the data plate located near the power cord for the electrical specifications of cabinet as shown on page 3.
 - With the the POWER switch OFF, plug the cord into the appropriate rated, grounded receptacle.
 - Cabinets rated at 120V 1440W must be plugged into either a 15 amp or 20 amp 125VAC receptacle.
 - Cabinets rated at 120V 2000W must be plugged into a 20 amp 125VAC receptacle.
 - Cabinets rated at 220-240V must be plugged into a 15 amp 250VAC receptacle.
- B. With POWER switch OFF, plug into a grounded receptacle.
- C. Fill the stainless steel water pan to 1/2" from the top with clean HOT tap water for Proofing or if moisture is desired for Holding. Check water level every 3 hours (2 hours when Proofing) and refill with clean HOT tap water as necessary. Water pan does not have to be filled for Holding. Proofing and Moisture Holding Module require water pan to be filled if moisture control is turned on.

HOLDING INSTRUCTIONS (Combo, Holding & Moisture Holding)

1. Set Combination Module switch to HOLD.
2. Set POWER switch to the ON position.
3. Set TEMPERATURE control to 10.
4. On Moisture Holding only: Set MOISTURE control to 10.
5. Pre-heat cabinet until desired temperature is reached (typical heat-up time from 72°F (22°C) ambient to 160°F (71°C) is approximately 45 minutes).
6. Re-set TEMPERATURE control and adjust as necessary to reach the desired temperature (setting 6-8 typical for 150°F (66°C) to 160°F (71°C)). Power indicator light will turn on and off as the heat thermostats cycles.
7. On Moisture Holding only: Adjust MOISTURE control to desired level (10 being highest level, 1 lowest level, OFF being no heat to the water). The indicator lights will turn on and off as the heat and moisture thermostats cycle.

Figures Shown in °F

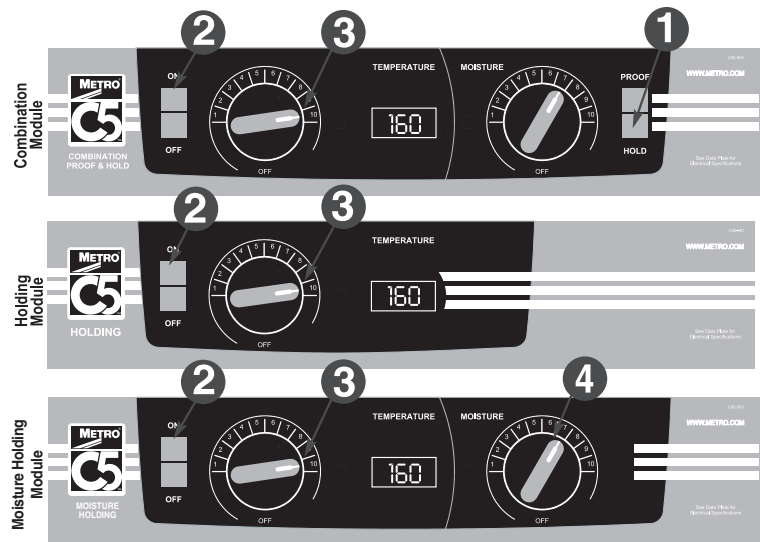

PROOFING INSTRUCTIONS (Combo & Proofing)

1. Set Combination Module switch to PROOF.
2. Set POWER switch to the ON position.
3. Set TEMPERATURE control to 2.
4. Set MOISTURE control to 10.
5. Pre-heat cabinet until desired temperature and humidity is reached (typical heat-up time from 72°F (22°C) ambient to 95°F (35°C) and 95% relative humidity is approximately 30 minutes).
6. Adjust settings as necessary to reach the desired temperature and humidity levels. Power indicator lights will turn on and off as the heat and moisture thermostats cycle.
7. Adjust MOISTURE control to desired level (10 being highest level, 1 lowest level, OFF being no heat to the water). The indicator lights will turn on and off as the heat and moisture thermostats cycle.

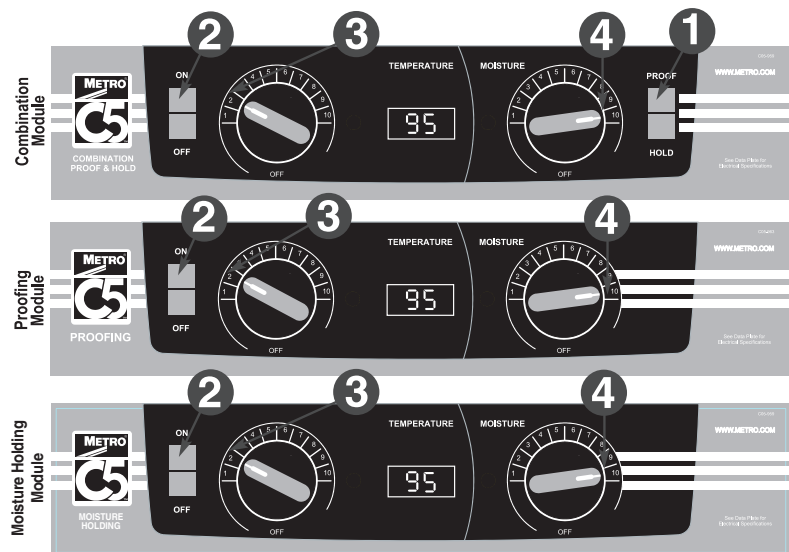

When the power switch is on, the blower is always energized, circulating air, and the digital thermometer is always displaying the cabinet temperature. When the thermostat senses heat is required, the appropriate indicator will light and the heater element will begin to produce heat.

- At the end of the operating day, it is not necessary to disrupt the temperature setting to turn the cabinet off. By switching the power switch off, the cabinet is no longer operating. When resuming operations, switch the power on and the cabinet will attain the previous temperature and moisture levels.

OPERATING INSTRUCTIONS (continued)

Caution: The stainless steel water pan must be in place during module operation.

Caution: Water inside this cabinet's pan is hot during use! Turn off and allow the water to cool before emptying the pan.

Note: The POWER switch is not a foot switch. Using it as a foot switch can damage the switch and make the cabinet inoperable.

Warning: Follow all food safety guidelines. Preheat the cabinet to the desired temperature before putting cooked, hot food into the cabinet. This is not a rethermalization cabinet. Food must be at the appropriate temperature before being placed into this cabinet.

- Your C5 1 Series or 3 Series cabinet is capable of creating some humid air. As you operate the cabinet and open and close the door(s), condensation may form on the inside surfaces of the cabinet. Some dripping of water may occur to the outside of the cabinet particularly at the door seals. Water may also drip off opened doors onto the floor.

Caution: Water dripping onto the floor from open doors can be a slip hazard.

Note: When turning the cabinet off at the end of the workday, it is recommended to leave the door(s) open to prevent heat and condensation build up within the cabinet.

FOOD HOLDING GUIDELINES

Combo and Holding Modules

Recommended Food Holding Guidelines

Food Product	Covered/Uncovered	Temperature Setting
Baked Fish	Uncovered	175°F (79°C)
Baked Potatoes	Uncovered	180°F (82°C)
Biscuit	Uncovered	180°F (82°C)
Broccoli	Covered	170-175°F (77-79°C)
Chicken Nuggets	Uncovered	175°F (79°C)
Corn on the Cob	Covered	170-175°F (77-79°C)
Croissants	Uncovered	175°F (79°C)
Egg Patties	Covered	180°F (82°C)
French Fries**	Uncovered	185°F (85°C)
Fried Chicken	Uncovered	180-185°F (82-85°C)
Fried Fish	Uncovered	180°F (82°C)
Hamburgers	Covered	180°F (82°C)
Lasagna	Covered	185°F (85°C)
Mashed Potatoes	Covered	175°F (79°C)
Mixed Veggies	Covered	170-175°F (77-79°C)
Pancakes	Covered	175°F (79°C)
Pasta	Covered	180°F (82°C)
Peas	Covered	170-175°F (77-79°C)
Pizza	Uncovered	175-180°F (79-82°C)
Roast Beef	Uncovered	170-180°F (77-82°C)
Roast Pork	Uncovered	170-180°F (77-82°C)
Scalloped Potatoes	Covered	175°F (79°C)
Strip Steak	Uncovered	160-170°F (71-77°C)
Turkey	Uncovered	170-180°F (77-82°C)
Waffles	Covered	175°F (79°C)
Whole Chicken	Uncovered	170-180°F (77-82°C)

*Temperatures are guidelines only, based on opening cabinet doors every 15 minutes.

**Lightly salted for best quality.

Developed by Penn State University School of Hotel, Restaurant, and Recreation Management

CARE & MAINTENANCE

Cleaning The Cabinet

Warning: Unplug the cabinet before cleaning or servicing. Do not wash the cabinet with a water jet or high-pressure water.

Warning: Allow the unit to cool before cleaning, as the interior of the cabinet may be hot enough to burn. Also, allow the water in the pan to cool before removal.

Caution: Do not spray or pour water into the control module. To clean the cabinet and module, wipe with a damp cloth and dry with a towel. Use only cleaning agents approved for aluminum.

Caution: Do not use strong alkalis as it may discolor aluminum.

- Use cleaners in the proper concentrations. Follow the manufacturer's directions for the cleaning product used. After using any cleaning products, thoroughly rinse all surfaces to remove all residue.
 - Use a damp cloth or sponge. Mild soap suitable for aluminum is acceptable. Dry with a clean towel. Wipe up spills as soon as possible and regularly clean the cabinet to avoid staining and difficult to clean conditions.
 - If a control knob needs to be removed for cleaning, remove the knob, clean the knob recess and knob, and replace the knob.
1. When removing the module, make sure the power cord is NOT hooked onto the cord keeper. Open the door(s). If there is water in the stainless steel pan, remove and empty. Remove the module from the cabinet by lifting up the front enough to clear its detent, and then pull the module away from the cabinet. The power cord slips through the clearance hole at the rear of the cabinet.
 2. Remove the slide racks.
 3. After cleaning, replace all components. Make sure the slide racks are seated in the hangers correctly.
 4. Push the power cord through the plastic snap bushing in the rear of the cabinet and install the module.

Cleaning Instructions for Clear, Polycarbonate Doors (if applicable):

The protective masking on the polycarbonate door may be removed by simply peeling it from the door, starting at a top corner and working downward. For regular cleaning, a soft cotton flannel cloth and a cleaner recommended by its manufacturer for use on polycarbonate plastics is suggested. Do not use synthetic cloths or cleaners not intended for polycarbonate plastics as these will scratch and dull the polycarbonate door panel. Additional hints for keeping the door panel clean and clear:

1. Isopropyl (rubbing) alcohol, used as a cleaner, will aid in removing grease smudges and fingerprints.
2. A small amount of liquid dish detergent in a bucket of water will help remove heavier dirt and will help make the clear panel antistatic and therefore less likely to attract dust.
3. A paste-wax recommended for polycarbonate plastics and approved for food service equipment will hide small scratches and return the luster and clarity to the clear door panel as well as reduce the electrostatic attraction of dust.

Cleaning Instructions for 3 Series Insulation Armour Panels on Sides, Top and Back:

Use soft cloth, mild soap water solution to clean lightly-soiled surfaces. Then wipe dry with a clean, soft cloth. For heavily-soiled areas, use a soft brush and solvent or emulsion-based cleaner. Always insure the cleaner is recommended for use on plastics and follow any special instructions from the manufacturer.

Cabinet Maintenance:

Regularly inspect this product. Tighten loose fasteners and replace worn or damaged parts with new InterMetro approved parts. For mobile units, replace worn or damaged casters immediately; if equipped with grease fittings, lubricate casters regularly.

BASIC TROUBLESHOOTING

Module operation basics:

When the power switch is on, the blower is always energized, circulating air, and the digital thermometer is always displaying the cabinet temperature. A thermostat controls whether an element will be energized depending on the thermostat setting and the air temperature it is sensing. The control knob is used to change the thermostat setting. When a thermostat senses the temperature has gone below its set point, the thermostat contacts close, the appropriate indicator will light and the heater element will begin to produce heat. When the thermostat senses the temperature has reached its set point, the contacts open, the indicator light will go out and the heater element will stop producing heat.

Holding Module: The holding module has one heating element. It is in the air duct and heats up the air as it is circulated in the cabinet. The thermostat senses the return air temperature and will energize the air duct element as required to heat up the cabinet air. Some moisture can be introduced by filling the stainless steel water pan with warm water and allowing the warm air to pick up the water vapor as the blower circulates the air. There is no heating element to heat the water.

Moisture Holding and Proofing Module: There are two heating elements in these modules. One is in the air duct to heat the air, and one is under the stainless steel water pan to heat the water and introduce moisture into the cabinet. One thermostat senses the return air temperature and will energize the air duct element as required to heat up the cabinet air. The other thermostat senses the air temperature around the water pan. It will energize the water pan element to heat the water and release moisture into the cabinet.

Combination Proof and Hold Module: A combination proof and hold module has a mode switch, which allows the module to act as either a holding module or a proofing module. Therefore, it has all the elements of both a holding module and a proofing module. When the mode selector switch is set to HOLD, only the larger wattage air element is used. The stainless steel water pan element is not used. When the mode selector switch is set to PROOF, the lower wattage air element and the water pan element are used but independently controlled by individual thermostats. See the appropriate paragraph above for more detail on how the Combination Proof and Hold Module operates in either holding or proofing mode.

Element wattages are shown in the chart below:

	20 amp, 2000 watt cabinet		15 amp, 1440 watt cabinet	
	Air Duct element	Water Pan element	Air Duct element	Water Pan element
Combination module	1950 watt and 675 watt	675 watt	1360 watt and 675 watt	675 watt
Holding module	1950 watt	none	1360 watt	none
Proofing module			675 watt	675 watt
Moisture Holding module	1360 watt	590 watt		

120V

Element wattages are shown in the chart below:

	220-240V, 1681-2000W cabinet		220-240V, 1210-1440W cabinet	
	Air Duct element	Water Pan element	Air Duct element	Water Pan element
Combination module	1950 watt and 675 watt	675 watt		
Holding module	1950 watt	none		
Proofing module			675 watt	675 watt
Moisture Holding module	1360 watt	590 watt		

220-240V

Note: When heating element(s) are not energized, the amp draw for the blower and digital thermometer is approximately 0.8 to 0.9 amps.

Warning: Only factory-approved service agents should attempt to service, repair or replace electrical components, wiring or power cord..

1. Controls do not work (digital thermometer and indicator light(s) not lit):
 - a. Check that the cabinet is plugged in.
 - b. Check that the outlet has power. Is electrical service fuse blown or circuit breaker tripped?
 - c. Check that the power switch is in the "On" position.
 - d. Check the cabinet wiring from the power cord to the power switch and to the terminal block.
 - e. Power switch could be bad.
2. Temperature too hot:
 - a. Temperature set point is too high. Turn control knob down to a lower setting. Wait several minutes and see if the displayed temperature decreases.
 - b. Thermostat may have failed with contacts closed. Check thermostat.
 - c. If displayed temperature exceeds 220°F (104°C):

BASIC TROUBLESHOOTING (continued)

- i. Blower wiring is faulty or disconnected.
 - ii. Blower needs replacing. Check blower.
 - iii. The thermostat or blower may have failed and the thermal overload device is controlling the temperature. Stop using the cabinet immediately and contact a factory-approved service agent.
3. Temperature too low:
 - a. The cabinet may still be in pre-heat or recovering from a door being opened.
 - b. Temperature set point is too low. Turn temperature control knob to a higher setting. Wait several minutes and see if the displayed temperature increases.
 - c. A door is not closed or sealing properly.
 - d. Blower is not circulating air:
 - i. Blower wiring is faulty or disconnected.
 - ii. Blower needs replacing.
4. Indicator light is not working:

It is rare that an indicator light will be defective but it is possible. The thermostat contacts may not be closing and therefore the heater element is not being energized. Check the thermostat and pilot light and their respective wiring.
5. No heat generated:
 - a. If the heat indicator light is on, but the cabinet does not draw the appropriate amperage per the chart on page 11.
 - i. Air heater element may be faulty.
 - ii. The wiring to the air heater element may be faulty or disconnected.
 - iii. The thermostat may be faulty.
 - b. If the heat indicator light is not on, the thermostat contacts may not be closing and therefore the heater element is not being energized. It is rare that the indicator light will be defective but it is possible. Check the thermostat and pilot light and their respective wiring.
6. Moisture level is too low:
 - a. If the heat indicator light is on, and the cabinet draws the appropriate amperage per the chart on page 11:
 - i. Check that the stainless steel water pan has water.
 - ii. A door is not closed or sealing properly.
 - iii. Moisture set point is too low. Turn moisture control knob to a higher setting.
 - b. If the heat indicator light is on, but the cabinet does not draw the appropriate amperage per the chart on page 11:
 - i. Air heater element may be faulty.
 - ii. The wiring to the air heater element may be faulty or disconnected.
 - iii. The thermostat may be faulty.
 - c. If the heat indicator light is not on, the thermostat contacts may not be closing and therefore the heater element is not being energized. It is rare that the indicator light will be defective but it is possible. Check the thermostat and pilot light and their respective wiring.
7. Cabinet trips GFCI (ground fault circuit interrupter):

A GFCI receptacle protects against "ground faults" whenever an electrical product is plugged into the GFCI outlet by constantly monitoring the electricity for any loss of current. If the current flowing out of the receptacle differs by a small amount from that returning, the GFCI quickly switches off power to that circuit. The GFCI interrupts power extremely fast to minimize the possibility of an electric shock.

 - a. The heater element may absorb some moisture into its casing and insulation during shipment or during long periods of not being used (such as during the summer in a closed school kitchen). Plug the cabinet (without water in the stainless steel water pan into a non-GFCI outlet, set the temperature to "10" and let it run for 30-60 minutes to dry out any moisture the element may have absorbed. (If it trips the standard circuit breaker call factory-approved service agent.) After drying the element, plug the cabinet into the GFCI outlet; the cabinet should run without tripping the GFCI.
 - b. If the cabinet still trips the GFCI, call a factory-approved service agent.

SERVICE and REPLACEMENT PARTS

C5 1 & 3 SERIES CABINETS (BOTH 120V & 220-240V)

ITEM #	Replacement Part No.	Description	ITEM #	Replacement Part No.	Description
CABINET BODY			OUTSIDE POLY PANELS ON C5 3 SERIES CABINETS		
1	RPC5-19-FCDR RPC5-17-FCDR RPC5-15-FCDR RPC5-39-TCDR RPC5-39-BCDR	COMPLETE FULL HEIGHT CLEAR DOOR COMPLETE 3/4 HEIGHT CLEAR DOOR COMPLETE 1/2 HEIGHT CLEAR DOOR COMPLETE TOP CLEAR DUTCH DOOR COMPLETE BOTTOM CLEAR DUTCH DOOR	23	RPC3-TPNL-BG RPC3-TPNL-BU RPC3-TPNL-GY RPC3-TPNL-RE	BEIGE TOP PANEL — INCLUDES SCREWS BLUE TOP PANEL — INCLUDES SCREWS GRAY TOP PANEL — INCLUDES SCREWS RED TOP PANEL — INCLUDES SCREWS
2	RPC5-39-FSDR RPC5-37-FSDR RPC5-35-FSDR RPC5-39-TSDR RPC5-39-BSDR	COMPLETE FULL HEIGHT SOLID DOOR COMPLETE 3/4 HEIGHT SOLID DOOR COMPLETE 1/2 HEIGHT SOLID DOOR COMPLETE TOP SOLID DUTCH DOOR COMPLETE BOTTOM SOLID DUTCH DOOR	24	RPC3-SD27-BG RPC3-SD27-BU RPC3-SD27-GY RPC3-SD27-RE	BEIGE 27" SIDE PANEL — INCLUDES SCREWS BLUE 27" SIDE PANEL — INCLUDES SCREWS GRAY 27" SIDE PANEL — INCLUDES SCREWS RED 27" SIDE PANEL — INCLUDES SCREWS
3	RPC14-119	DOOR HINGE (QTY. 1)	25	RPC3-SD21-BG RPC3-SD21-BU RPC3-SD21-GY RPC3-SD21-RE	BEIGE 21" SIDE PANEL — INCLUDES SCREWS BLUE 21" SIDE PANEL — INCLUDES SCREWS GRAY 21" SIDE PANEL — INCLUDES SCREWS RED 21" SIDE PANEL — INCLUDES SCREWS
4	RPC14-118 RPC14-118A	DOOR LATCH, OFFSET HANDLE DOOR LATCH, FLUSH HANDLE	26	RPC3-IA-BTPNL	BOTTOM SIDE PANEL — INCLUDES SCREWS
5	RPC06-910A RPC06-910B RPC06-910C RPC06-910D	FULL HEIGHT CLEAR DOOR GASKET 3/4 HEIGHT CLEAR DOOR GASKET 1/2 HEIGHT CLEAR DOOR GASKET CLEAR DUTCH DOOR GASKET	27	RPC3-IA-RTNR	MIDDLE PANEL RETAINER — INCLUDES SCREWS
6	RPC06-916A RPC06-916B RPC06-916C RPC06-916D	FULL HEIGHT SOLID DOOR GASKET 3/4 HEIGHT SOLID DOOR GASKET 1/2 HEIGHT SOLID DOOR GASKET SOLID DUTCH DOOR GASKET	28	RPC5-3-BASECLP	BOTTOM PANEL CLAMP & SCREWS
7	B5DNB RPQC02-248	5" BRAKE CASTER 6" BRAKE CASTER	29	RPC5-13-URT5* RPC5-13-URT7	FULL & 1/2 HEIGHT UNIV. UPRIGHTS (QTY. 1) *(Full height cabinet uses same uprights) 3/4 HEIGHT UNIV. UPRIGHTS (QTY. 1)
8	B5DN B5DNR RPQC02-247	5" SWIVEL CASTER 5" RIGID CASTER 6" SWIVEL CASTER	57	RPC519-PKG RPC515-PKG	FULL & 3/4 HEIGHT 1 AND 3 SERIES CABINET RETURN PACKAGING 1/2 HEIGHT 1 AND 3 SERIES CABINET RETURN PACKAGING
9	RPC5-SSLEG-1	STATIONARY EQUIPMENT LEG (QTY. 1)	58	RPC53-HGRKIT	REPLACEMENT RACK HANGER KIT — 1 PAIR
10	RPC5-DPTRH	POLY BUMPER/DRIP TROUGH & SCREWS			
11	RPC06-179	PLASTIC DRIP PAN			
12	RPC5-RHANDLE	REAR HANDLE & SCREWS (USED ONLY ON 1 SERIES)			
13	RPC5-TRVL	TRAVEL LATCH			
14	RPC5-1-BMPR	1 SERIES CORNER BUMPERS (2 FRONT, 2 REAR & SCREWS)			
15	RPC13-106	POWER CORD BUSHING			
16*	C5-13-FW-9 C5-13-FW-7 C5-13-FW-5	FULL HEIGHT FIXED WIRE SLIDES 3/4 HEIGHT FIXED WIRE SLIDES 1/2 HEIGHT FIXED WIRE SLIDES			
17*	RPC5-13-U9 RPC5-13-U7 RPC5-13-U5	FULL HEIGHT UNIV SLIDES & UPRIGHTS 3/4 HEIGHT UNIV SLIDES & UPRIGHTS 1/2 HEIGHT UNIV SLIDES & UPRIGHTS			
18*	C5-13-L9F C5-13-L9D C5-13-L-7 C5-13-L-5	FULL HEIGHT LIP LOAD SLIDES — 1 PAIR SPLIT FULL HEIGHT LIP LOAD SLIDES — 2 PAIR 3/4 HEIGHT LIP LOAD SLIDES 1/2 HEIGHT LIP LOAD SLIDES			
19	C5-USLIDEP-R C5-USLIDEP-S	CHROME UNIV WIRE SLIDES — 1 PAIR SS UNIVERSAL WIRE SLIDES — 1 PAIR			
20	C5-SHELF-S	ACCESSORY SHELF (USED WITH UNIVERSAL UPRIGHTS)			

*See pages 4 and 5 for slide identification.
All slides sold in pairs.
Universal slides include uprights.

SERVICE and REPLACEMENT PARTS (continued)

FOR C5 1 & 3 120V CABINET MODULES*

ITEM#	PART #	DESCRIPTION	MODULE TYPE: MODULE ELECTRICAL RATING:					MOISTURE HOLDING 2000W QTY
			COMBO 2000W QTY	HOLDING 2000W QTY	PROOFER 1440W QTY	COMBO 1440W QTY	HOLDING 1440W QTY	
30	RPC13-375	POWER SWITCH (RED)	1	1	1	1	1	1
31	RPC13-128	SELECTOR SWITCH (WHITE)	1	1				N/A
32	RPC06-913	THERMOSTAT KNOB	2	1	2	2	1	2
33	RPC13-721	THERMOSTAT	2	1	2	2	1	2
34	RPC09-213	THERMOSTAT MOUNTING CUP	2	1	2	2	1	2
35	RPC13-246	AMBER INDICATOR LIGHT	2	1	2	2	1	2
36	RPC13-237	DIGITAL THERMOMETER	1	1	1	1	1	1
37	RPC13-183	THERMOMETER TRANSFORMER	1	1	1	1	1	1
38	RPC11-191	BLOWER INTAKE COLLAR	1	1	1	1	1	1
39	RPHM20-2103	BLOWER	1	1	1	1	1	1
40	RPC13-365	HEAT ELEMENT, "M" SHAPED, 120V 1950W	1	1				N/A
40A	RPC13-366	HEAT ELEMENT, "M" SHAPED, 120V 1360W				1	1	1
41	RPC13-367	HEAT ELEMENT, "U" SHAPED, 120V 675W	2		2	2		N/A
42	RPC13-198	THERMAL CUT-OUT	1	1	1	1	1	1
43	RPC13-359	POWER CORD 15A, RT. ANGLE PLUG	1	1				1
	RPC13-099	POWER CORD, 20A, STR. PLUG						
	RPC5-RTWSTPLG	POWER CORD, 20A TWIST LOCK PLUG						
43A	RPC13-017	POWER CORD, 15A			1	1	1	N/A
	RPC13-348	POWER CORD 15A, RT. ANGLE PLUG						
	RPC13-289	POWER CORD 15A, STR. PLUG						
	RPC5-RTWSTPLG-15	POWER CORD, 15A TWIST LOCK PLUG						
44	RPC13-098	STRAIN RELIEF BUSHING, 20A CORD	1	1				1
44A	RPC13-083	STRAIN RELIEF BUSHING, 15A CORD			1	1	1	N/A
45	RPC13-096	TERMINAL BLOCK	1	1	1	1	1	1
46	RPC07-055	GROMMET	1	1	1	1	1	2
47	RPC56-SCLP	SENSOR & BULB CLAMP KIT	1	1	1	1	1	1
48	RPC11-185	STAINLESS STEEL WATER PAN	1	1	1	1	1	1
49	RPC06-206	STEM BUMPER, MODULE STOP	2	2	2	2	2	2
50	RPC13-368	HEAT ELEMENT, "U" SHAPED 120V, 590W						1

REPLACEMENT MODULES (120V)

51	RPC5-CM2000	REPLACEMENT COMBO, 120V, 2000W MODULE
52	RPC5-HM2000	REPLACEMENT HOLDING, 120V, 2000W MODULE
53	RPC5-PM1500	REPLACEMENT PROOFING, 120V, 1440W MODULE
54	RPC5-CM1500	REPLACEMENT COMBO, 120V, 1440W MODULE
55	RPC5-HM1500	REPLACEMENT HOLDING, 120V, 1440W MODULE
56	RPC5-MM2000	REPLACEMENT MOISTURE HOLDING, 120V, 2000W MODULE

*Check data plate at rear of cabinet to confirm cabinet voltage before selecting replacement parts.

SERVICE and REPLACEMENT PARTS (continued)

FOR C5 1 & 3 SERIES 220-240V CABINET MODULES*

ITEM#	PART #	MODULE TYPE: DESCRIPTION	COMBO QTY	HOLDING QTY	PROOFER QTY	MOISTURE HOLDING QTY
30	RPC13-375	POWER SWITCH (RED)	1	1	1	1
31	RPC13-128	SELECTOR SWITCH (WHITE)	1			N/A
32	RPC06-913	THERMOSTAT KNOB	2	1	2	2
33	RPC13-721	THERMOSTAT	2	1	2	2
34	RPC09-213	THERMOSTAT MOUNTING CUP	2	1	2	2
35	RPC13-246	AMBER INDICATOR LIGHT	2	1	2	2
36**	RPC13-248	THERMOMETER °C & 220-240V TRANSFORMER	1	1	1	1
38	RPC11-191	BLOWER INTAKE COLLAR	1	1	1	1
39	RPHX20-2103	BLOWER, 220-240V, 50/60HZ	1	1	1	1
40	RPC13-370	HEAT ELEMENT, "M" SHAPED, 240V, 1950W	1	1		N/A
40A	RPC13-371	HEAT ELEMENT, "M" SHAPED, 240V, 1360W				1
41	RPC13-369	HEAT ELEMENT, "U" SHAPED, 240V, 675W	2		2	N/A
42	RPC13-198	THERMAL CUT-OUT	1	1	1	1
43	RPC13-247	POWER CORD, 250VAC 15A, NEMA 6-15P	1	1	1	1
44	RPC13-083	STRAIN RELIEF BUSHING	1	1	1	1
45	RPC13-096	TERMINAL BLOCK	1	1	1	1
46	RPC07-055	GROMMET	1	1	1	2
47	RPC56-SCLP	SENSOR & BULB CLAMP KIT	1	1	1	1
48	RPC11-185	STAINLESS STEEL WATER PAN	1	1	1	1
49	RPC06-206	STEM BUMPER, MODULE STOP	2	2	2	2
50	RPC13-372	HEAT ELEMENT, 240V, 590W				1

REPLACEMENT MODULES (220-240V)

51	RPC5-CM2000X	REPLACEMENT COMBO, 220-240V, 1681-2000W MODULE
52	RPC5-HM2000X	REPLACEMENT HOLDING, 220-240V, 1681-2000W MODULE
53	RPC5-PM1500X	REPLACEMENT PROOFING, 220-240V, 1210-1440W MODULE
54	RPC5-MM2000X	REPLACEMENT MOISTURE HOLDING, 220-240V, 1681-2000W MODULE

*Check data plate at rear of cabinet to confirm cabinet voltage before selecting replacement parts.

**Thermometer and Transformer are serviced as one unit.

SERVICE and REPLACEMENT PARTS (continued)

C5 1 Series Cabinet Replacement Parts Diagram (Both 120V & 220-240V)

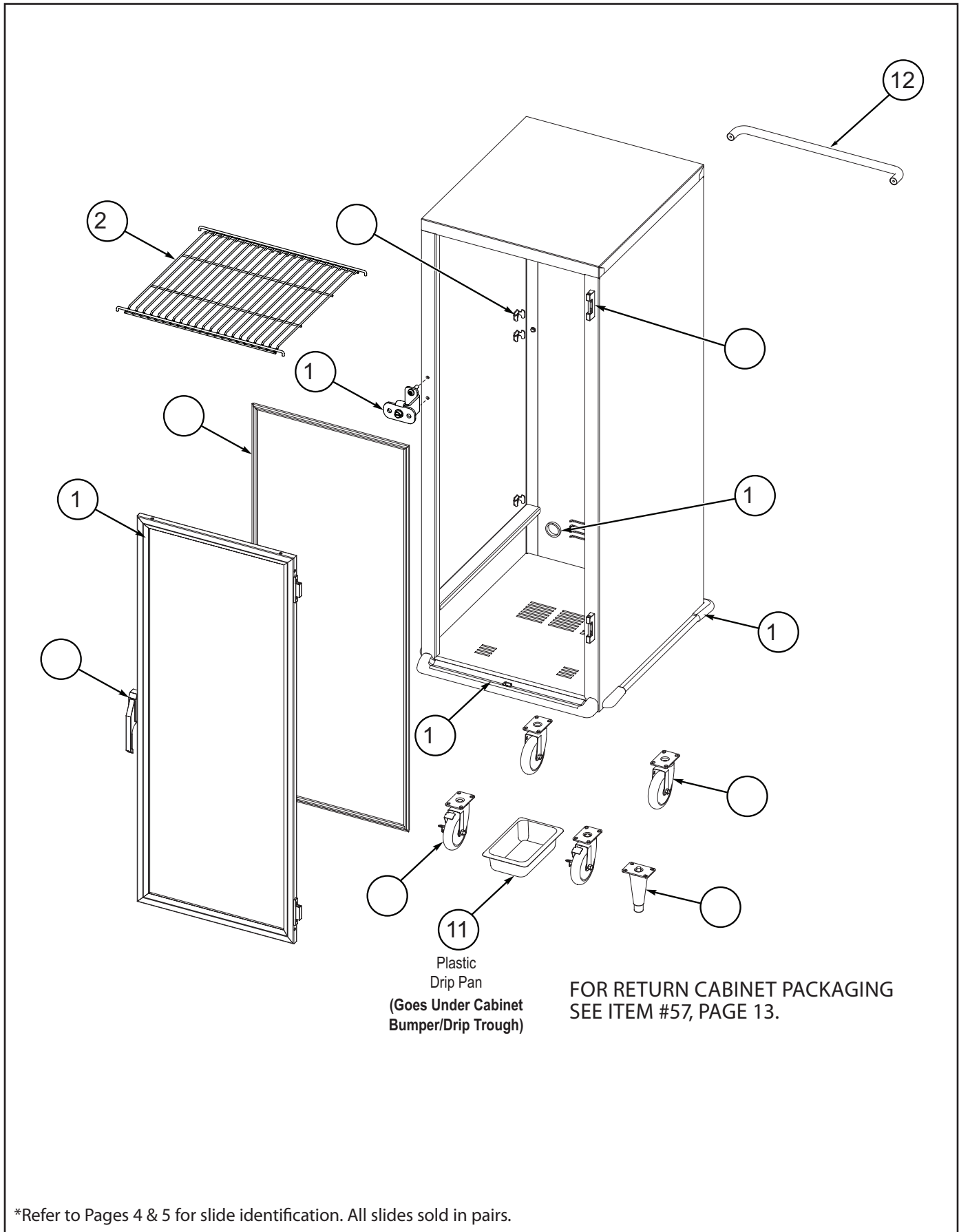

SERVICE and REPLACEMENT PARTS (continued)

C5 3 Series Cabinet Replacement Parts Diagram (Both 120V & 220-240V)

NOTE: Replacement panels are ordered by color.
See chart on page 13.

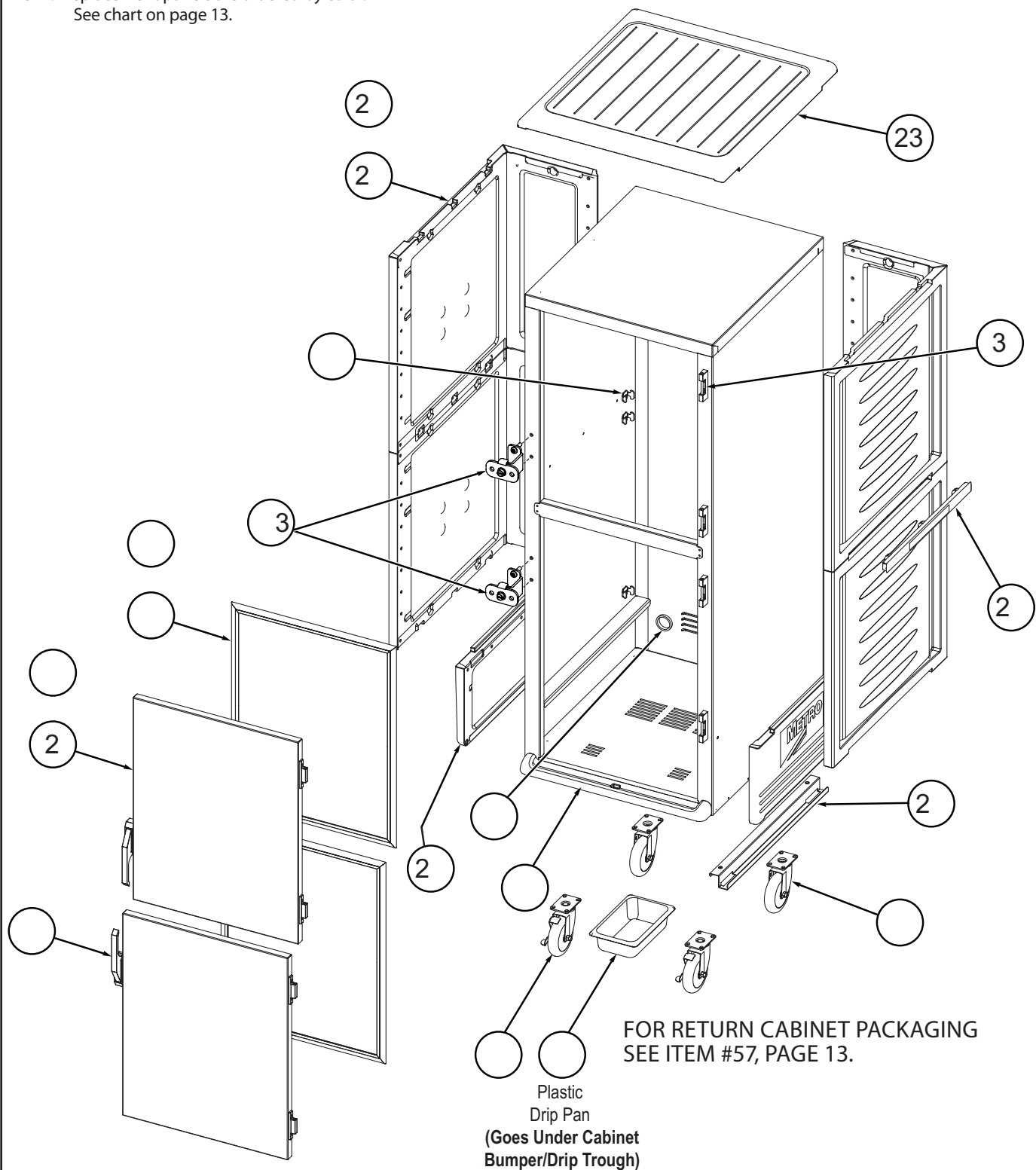

*Refer to Pages 4 & 5 for slide identification. All slides sold in pairs.

SERVICE and REPLACEMENT PARTS (continued)

(For 120V parts see Page 14 & for 220-240V parts see Page 15)

COMBO MODULE

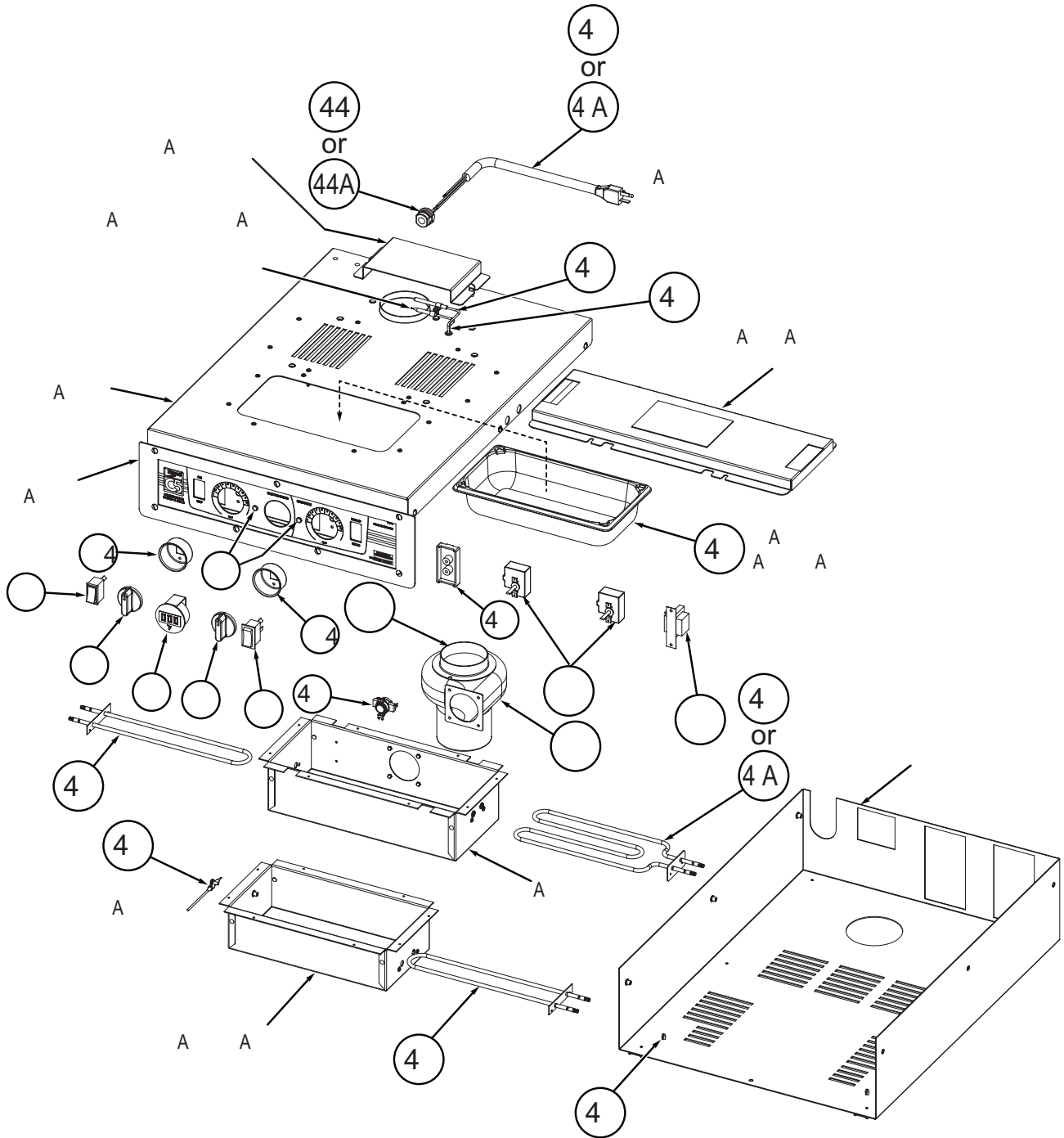

FOR 120V REPLACEMENT C5-CM2000 MODULE, ORDER ITEM #51 ON PAGE 14

FOR 120V REPLACEMENT C5-CM1500 MODULE, ORDER ITEM #54 ON PAGE 14

FOR 220-240V REPLACEMENT C5-CM2000X MODULE, ORDER ITEM #51 ON PAGE 15

**ON 220-240V MODULES THERMOMETER AND TRANSFORMER ARE SERVICED AS ONE UNIT.

SERVICE and REPLACEMENT PARTS (continued)

(For 120V parts see Page 14 & for 220-240V parts see Page 15)

HOLDING MODULE

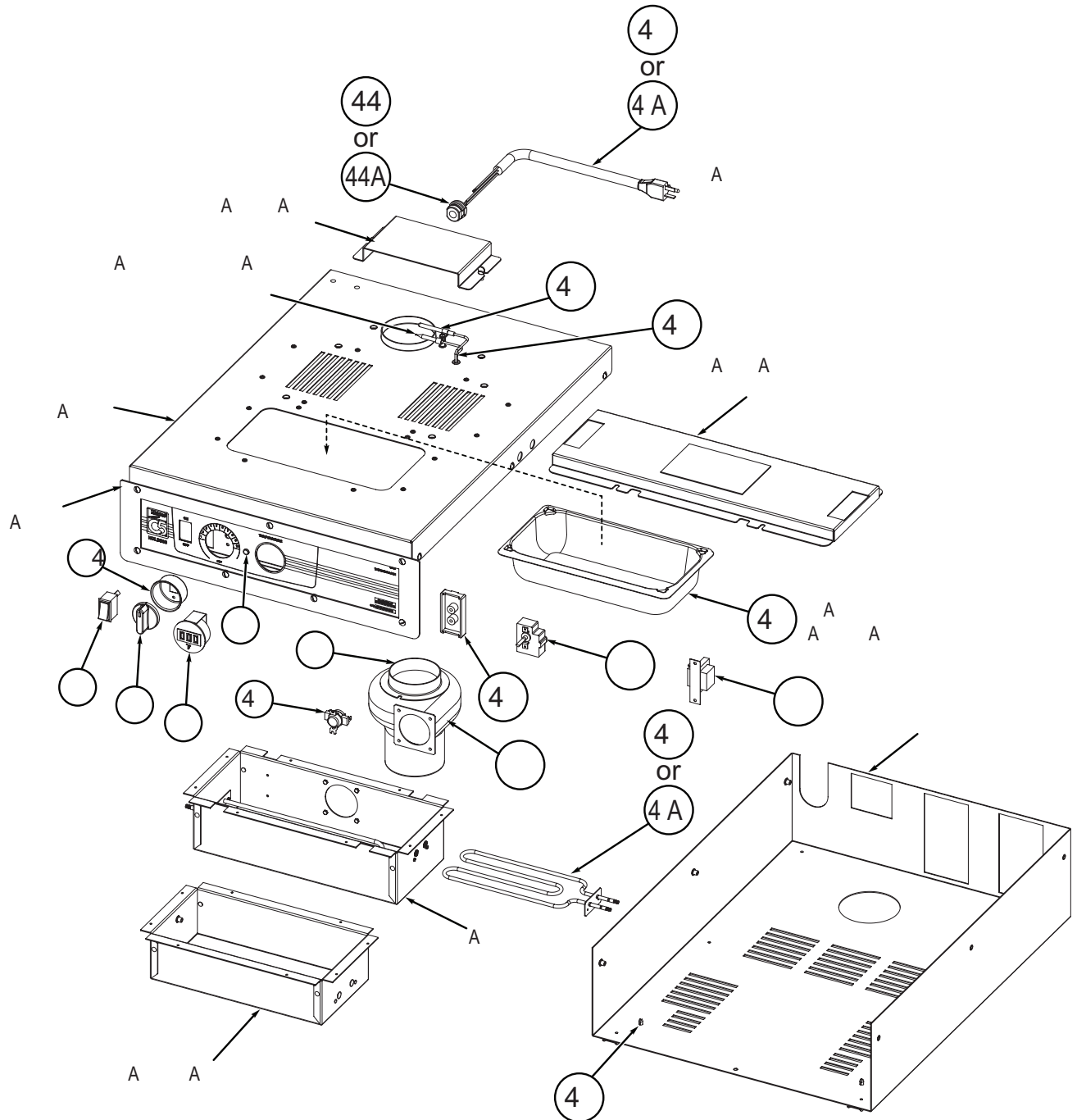

FOR 120V REPLACEMENT C5-HM2000 MODULE, ORDER ITEM #52 ON PAGE 14

FOR 120V REPLACEMENT C5-HM1500 MODULE, ORDER ITEM #55 ON PAGE 14

FOR 220-240V REPLACEMENT C5-HM2000X MODULE, ORDER ITEM #52 ON PAGE 15

**ON 220-240V MODULES THERMOMETER AND TRANSFORMER ARE SERVICED AS ONE UNIT.

SERVICE and REPLACEMENT PARTS (continued)

(For 120V parts see Page 14 & for 220-240V parts see Page 15)

MOISTURE HOLDING MODULE

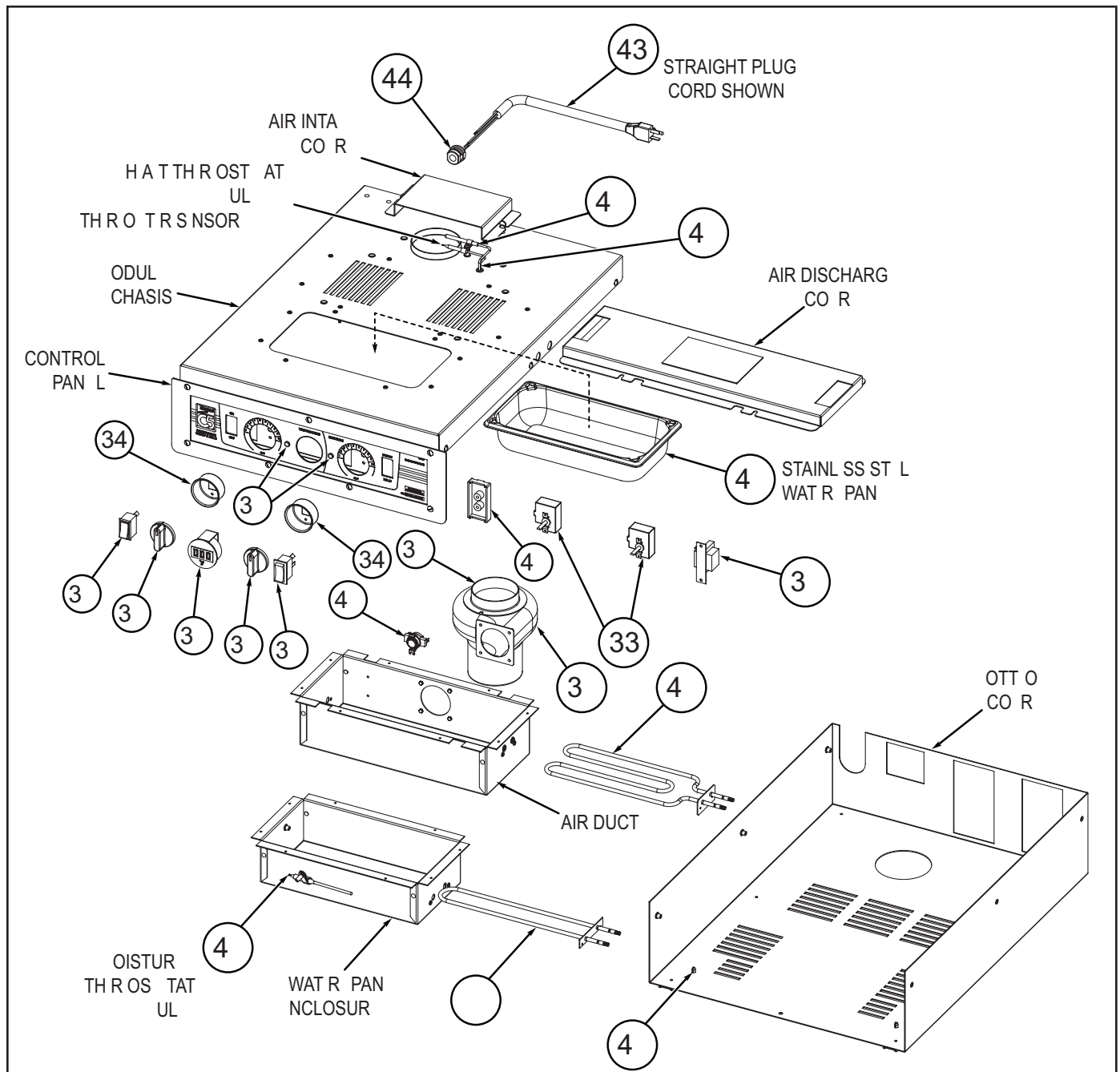

FOR 120V REPLACEMENT C5-MM2000 MODULE, ORDER ITEM #56 ON PAGE 14

FOR 220-240V REPLACEMENT C5-MM2000X MODULE, ORDER ITEM #54 ON PAGE 15

**ON 220-240V MODULES THERMOMETER AND TRANSFORMER ARE SERVICED AS ONE UNIT.

SERVICE and REPLACEMENT PARTS (continued)

WIRING DIAGRAM — COMBO MODULE

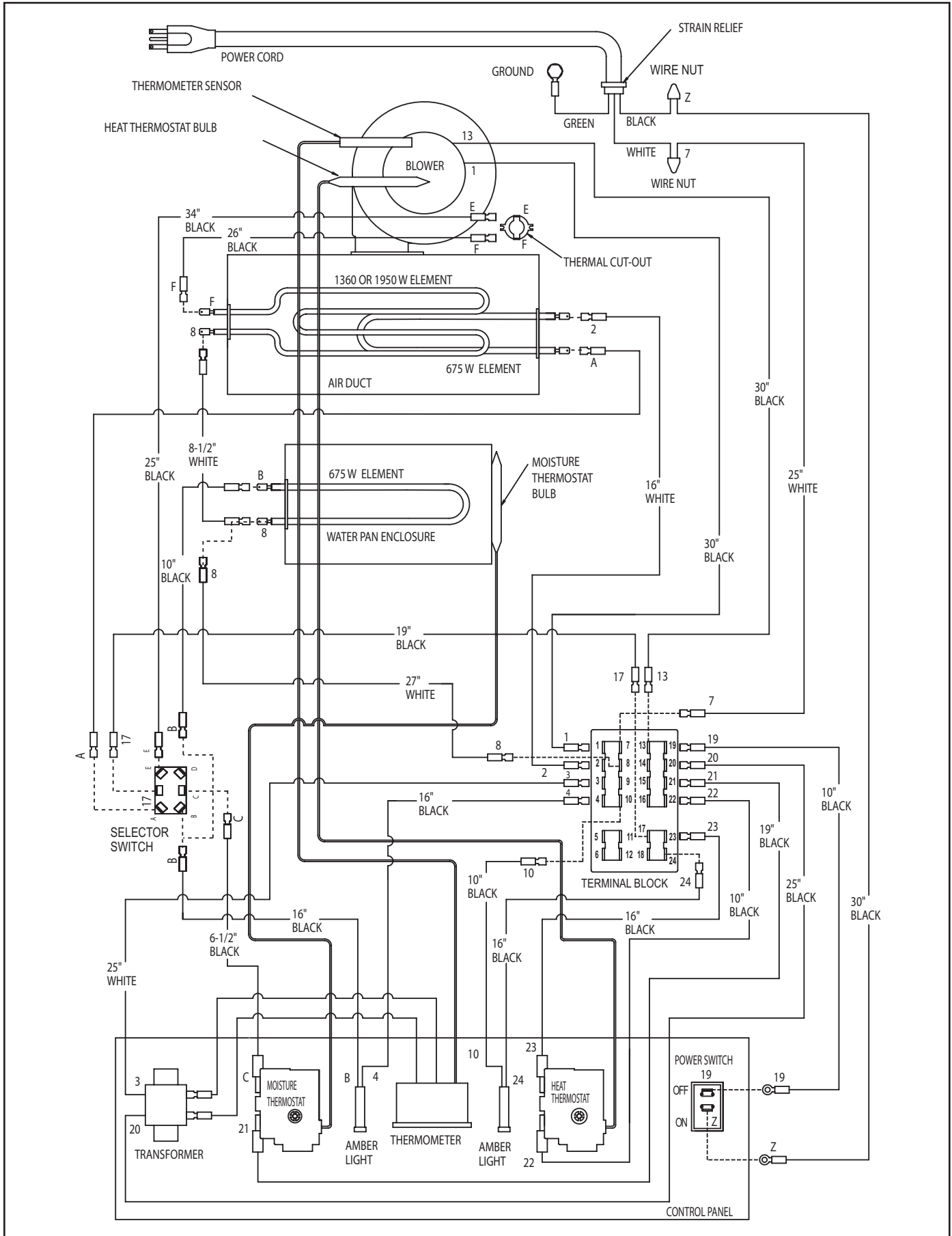

SERVICE and REPLACEMENT PARTS (continued)

WIRING DIAGRAM — HOLDING MODULE

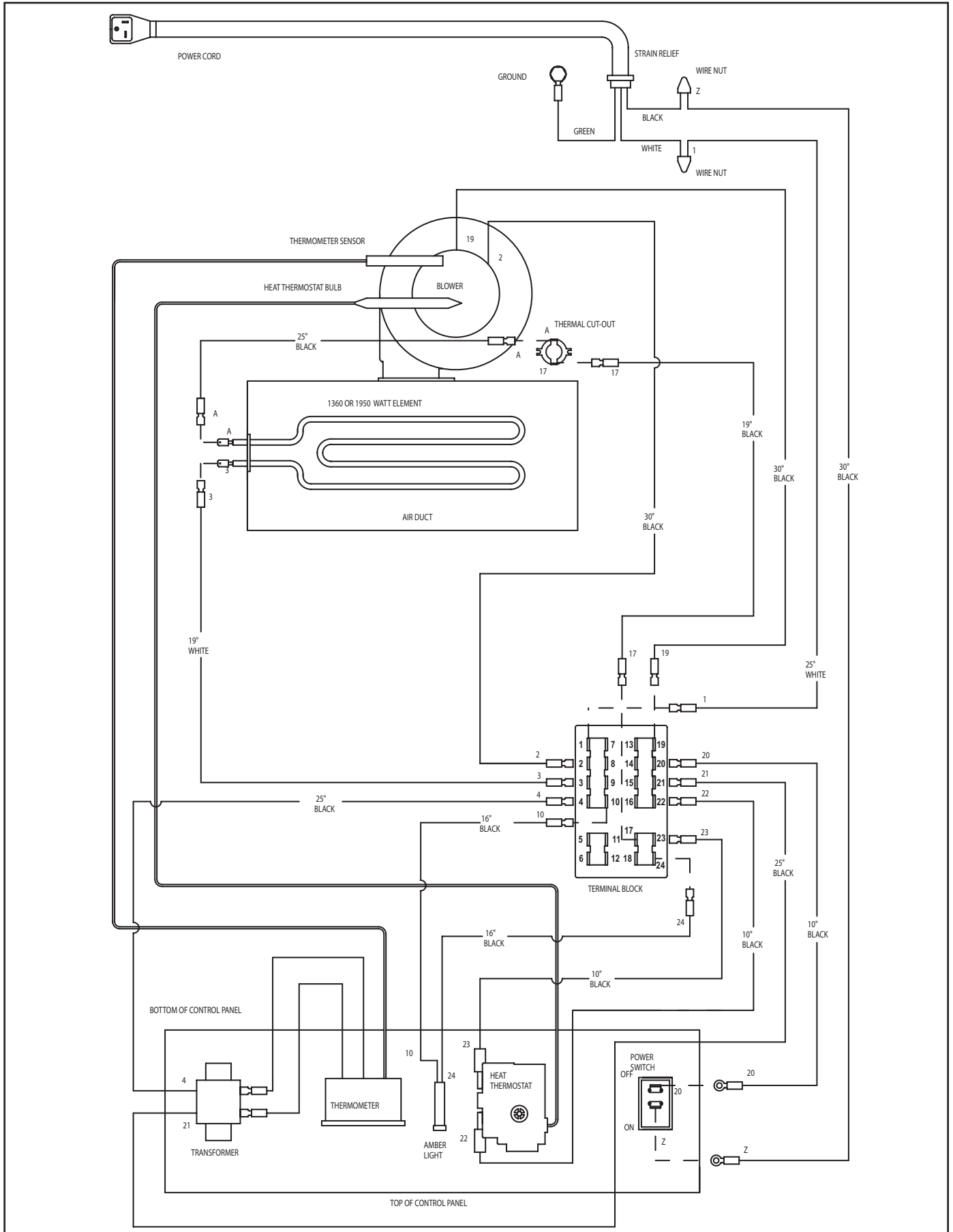

SERVICE and REPLACEMENT PARTS (continued)

WIRING DIAGRAM — PROOFING MODULE

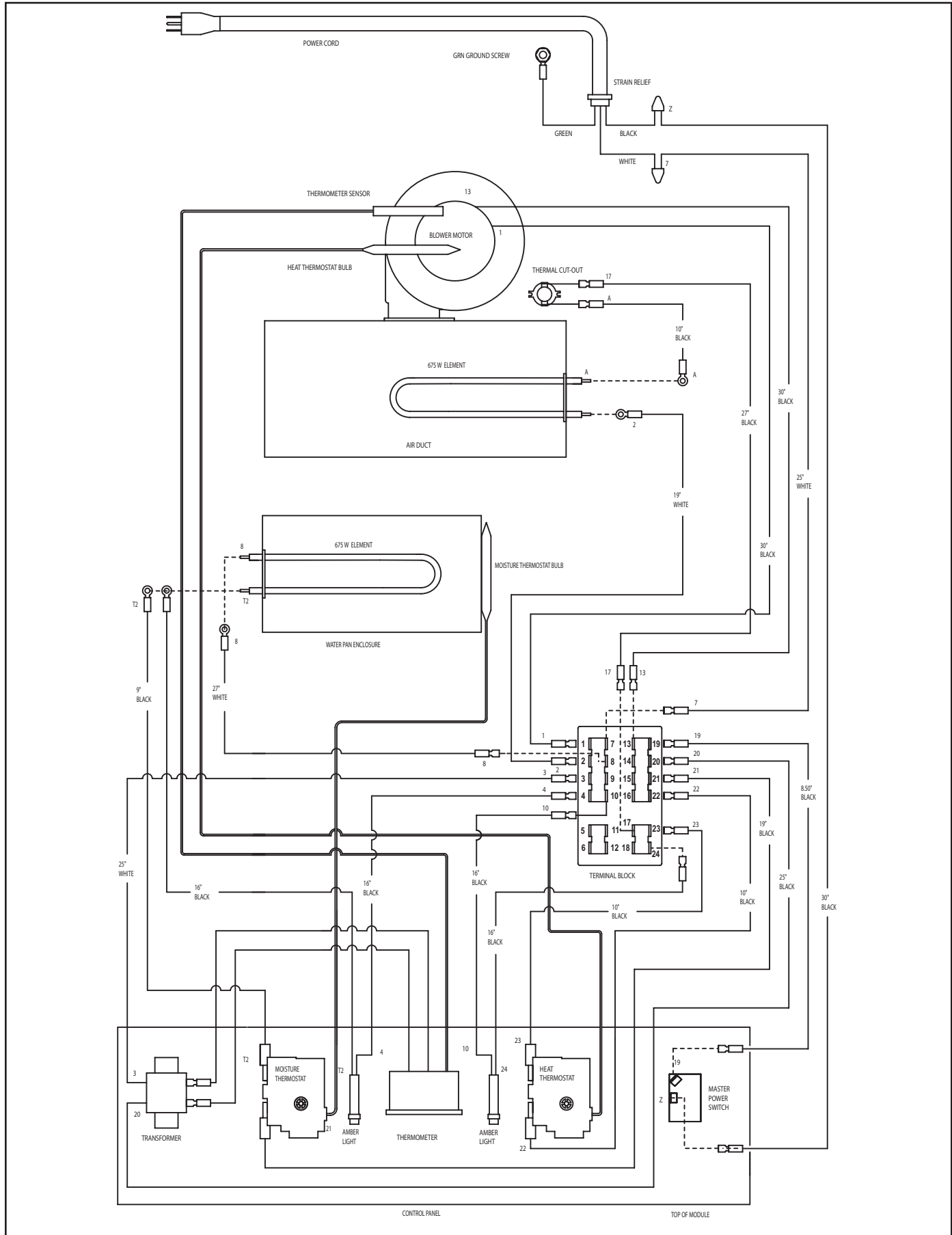

SERVICE and REPLACEMENT PARTS (continued)

WIRING DIAGRAM — MOISTURE HOLDING MODULE

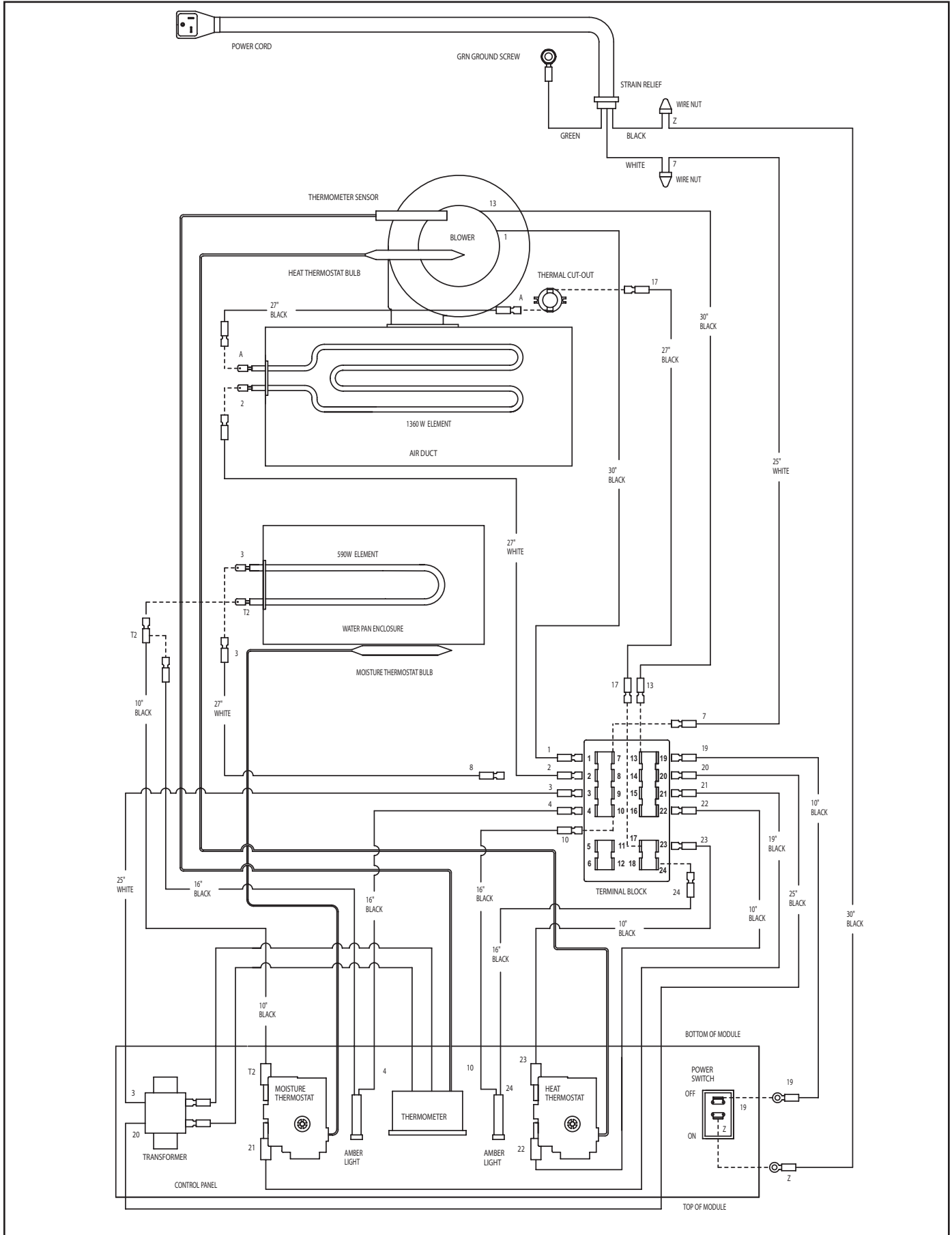

Warranty

WARRANTY, EXCLUSION OF WARRANTIES AND LIMITATION OF LIABILITY.

InterMetro Industries Corporation (hereinafter referred to as "Seller") warrants to the original purchaser that all products in its catalog, or custom products, delivered hereunder will be free from defects in workmanship and material. THE FOREGOING WARRANTY IS EXCLUSIVE AND IN LIEU OF ALL OTHER WARRANTIES, EXPRESS, IMPLIED OR STATUTORY, INCLUDING ANY WARRANTY OF MERCHANTABILITY OR FITNESS FOR A PARTICULAR PURPOSE. This Warranty shall be for a period of one (1) year from the date of shipment from Seller's warehouse or factory. If any product delivered hereunder does not meet the Warranty specified above, providing the product has not been altered in any way by anyone other than Seller's factory-authorized representative, and assuming normal and proper use and maintenance, Seller will, at its option, repair or replace any part or material it determines, upon inspection, to be defective; provided however, that a charge for labor will be made except during a period of one (1) year from the date of original shipment from Seller's warehouse or factory. No product, or part thereof, is to be returned to Seller without prior written approval from Seller's factory. All exchanges and replacement shipments will be F.O.B. Seller's factory. Warranties for equipment or articles not manufactured by the Seller are solely the warranties of the manufacturers thereof and they are hereby assigned to the purchaser without recourse to the Seller.

SELLER'S LIABILITY FOR ANY CLAIM OF ANY KIND, WHETHER BASED ON CONTRACT, NEGLIGENCE OR STRICT LIABILITY IN TORT, AND BY WHOMEVER MADE, FOR ANY DIRECT, INDIRECT, INCIDENTAL OR CONSEQUENTIAL LOSS, DAMAGE OR INJURY, RESULTING TO THE PURCHASER OR ANY THIRD PARTIES, arising out of, connected with or resulting from this Agreement, or from the performance or breach thereof, or from the manufacture, sale, delivery, resale, installation, inspection, repair or use of any product covered by or furnished under this Agreement, WHETHER OR NOT CAUSED BY SELLER'S NEGLIGENCE, SHALL IN ALL EVENTS BE EXCLUSIVELY LIMITED TO THE COST OF CORRECTING DEFECTIVE, DAMAGED OR NON-CONFORMING PARTS OR MATERIAL AS HEREIN PROVIDED, and upon the expiration of one (1) year, all such liability shall terminate.

SELLER DOES NOT AUTHORIZE any person to assume for it any obligations or liabilities greater than or different than those set forth in this Warranty. The terms under which any of Seller's products may be resold must be limited in accordance with this Warranty.

THIS AGREEMENT, and all the rights and obligations arising hereunder, shall be construed in accordance with, and be governed by, the law of the Commonwealth of Pennsylvania, U.S.A.

TO INSURE WARRANTY implementation, return the completed registration card within 15 days of cabinets' receipt to: InterMetro Industries Corp., Wilkes-Barre, PA 18705



InterMetro Industries Corporation
Wilkes-Barre, PA 18705

08/15

Thank you for purchasing a Metro C5 Controlled Temperature Cabinet. We are certain you will be more than satisfied with its quality and performance. Please fill in the warranty information space below so we may register your warranty. Also, so that we may learn more about our customers and hopefully be of continued service in the future, please take a moment to fill in the customer information space below.

Thank You

CUT ALONG DOTTED LINE

CUSTOMER INFORMATION

1. Which one of the following best describes your establishment?
- a. Full-Service Restaurant
 - b. Banquet Hall
 - c. Hotel/Motel
 - d. Hospital/Nursing Home
 - e. College/University
 - f. School
 - g. Employee Feeding
 - h. Other _____

WARRANTY INFORMATION:

- Cabinet Model No. _____
- Cabinet Serial No. _____
- Date Purchased _____
- Customer Name _____
- Address _____
- _____
- Phone No. _____

For warranty coverage please fill out this card and return it to Metro, or go to www.metro.com/heatedcabinetsupport and select Online Warranty Registration to register electronically.

FOLD HERE — DO NOT DETACH

2. Please indicate the two product benefits that were of major interest to you.
- a. Easy-to-use controls
 - b. Door selection
 - c. Size Selection
 - d. Cabinet capacity
 - e. Slide selection
 - f. Easy-to-clean design
 - g. Other
- _____
- _____
- _____

3. Main factor that led to your decision to purchase this product?
- a. Product operating and functional features
 - b. Overall quality
 - c. Price
 - d. Availability
 - e. Other _____
4. Three sources that led to the purchase of his product — in the order of their impact (1 — being most impact; 3 — being least impact).
- a. Trade Journal Ad
 - b. Trade Show
 - c. Sales Call
 - d. Direct Mail
 - e. Previous Purchase
 - f. Other _____

CUT ALONG DOTTED LINE



INTERMETRO INDUSTRIES CORPORATION
ATTN: CUSTOMER SERVICE
P O BOX A
WILKES-BARRE PA 18705-9968

POSTAGE WILL BE PAID BY

BUSINESS REPLY MAIL
FIRST-CLASS/STAINLESS STEEL PERMIT NO. 121 WILKES-BARRE, PA

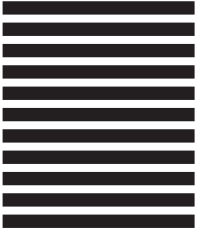

NO POSTAGE
NECESSARY
IF MAILED
IN THE
UNITED STATES

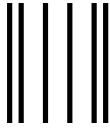

FOLD HERE — DO NOT DETACH

STAPLE HERE

STAPLE HERE

STAPLE HERE

PAGE INTENTIONALLY LEFT BLANK

PAGE INTENTIONALLY LEFT BLANK



InterMetro Industries Corporation
North Washington Street, Wilkes-Barre, PA 18705
For Product Information Call: 1-800-992-1776
Visit Our Web Site: www.metro.com

L01-430 Rev. J 08/2015
Information and specifications are subject to change
without notice. Please confirm at time of order.