

OWNER'S MANUAL

MOBILE HANDWASH STATION

This owner's manual applies to the following
Mobile Handwash Station models:

MHWS18



CAMBRO
TRUSTED FOR GENERATIONS™

www.cambro.com

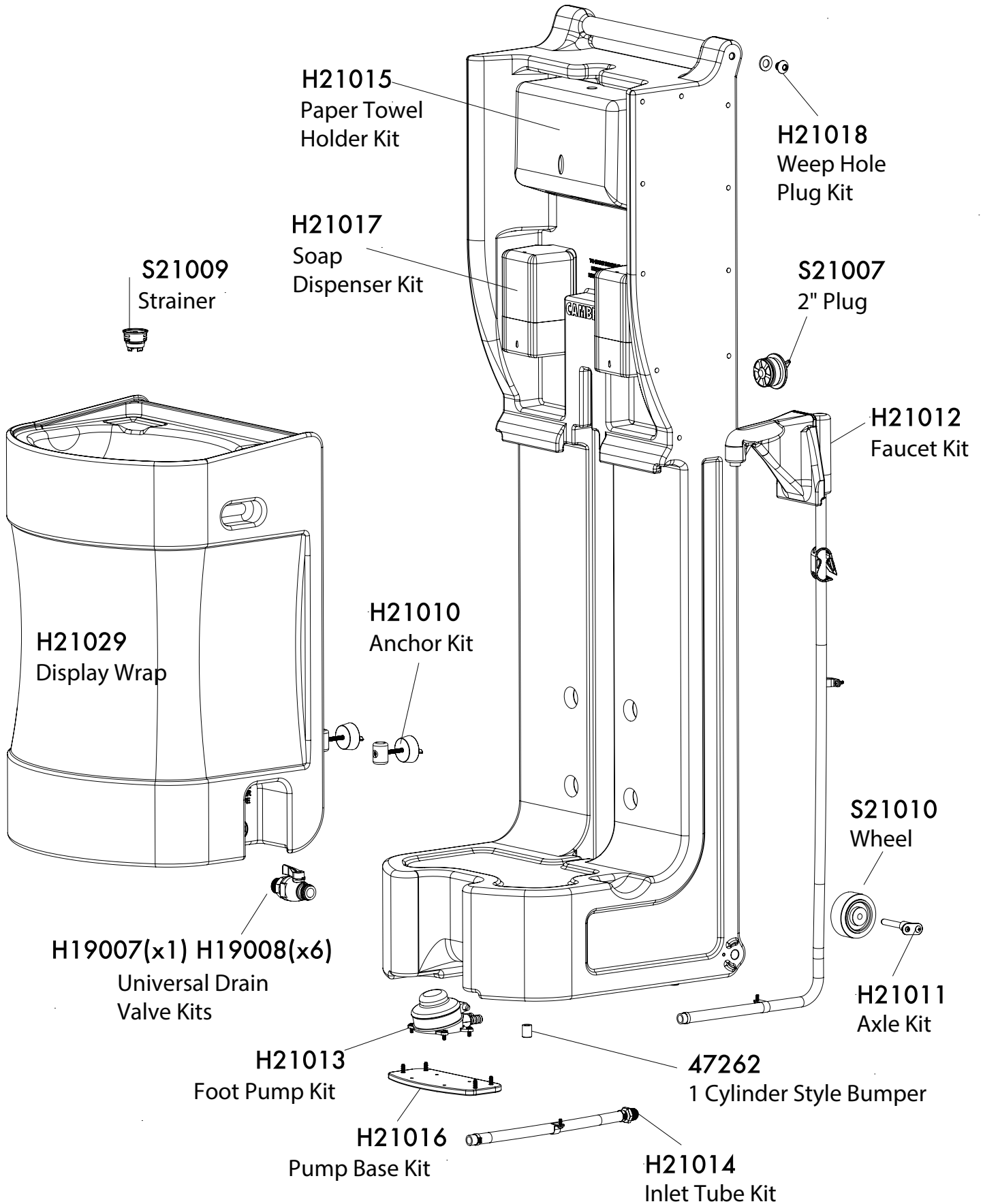

II. Usage Guidelines

Filling the Freshwater Tank

Fill the freshwater tank with a standard hose until water begins to overflow and/or use a finger to feel if the water has reached the max fill line. The fill time from empty to full will take 2-3 minutes on average.

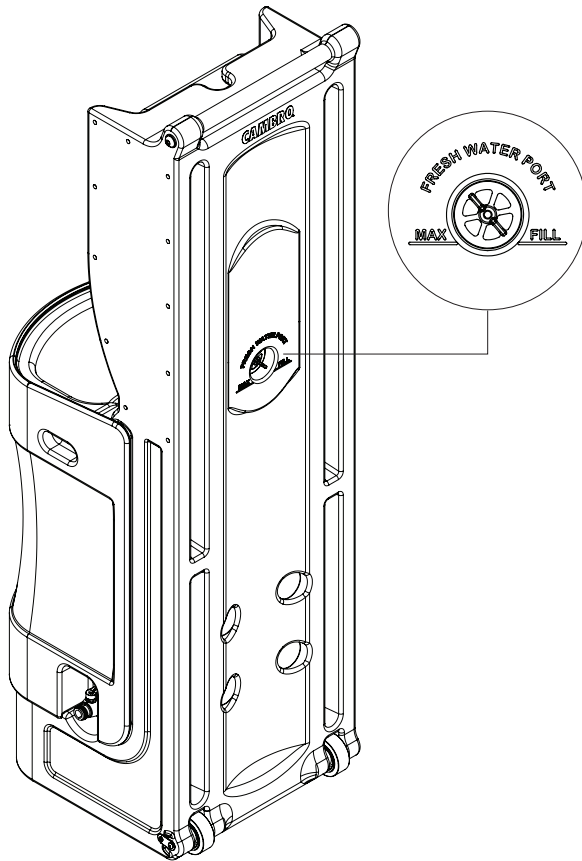

Operating the Unit:

Repeatedly depress foot pump to start and continue the flow of fresh water from the faucet. When finished, simply discontinue depressing foot pump.

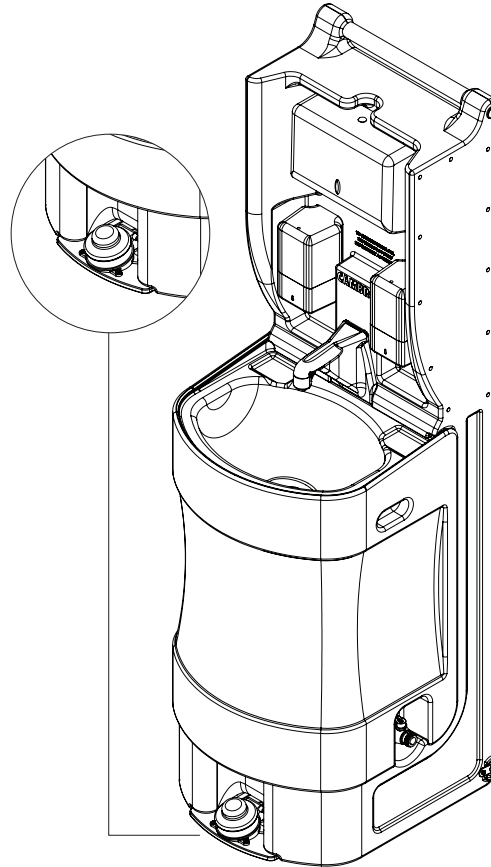

Scan to watch videos for filling and draining this unit.

Draining the Freshwater Tank:

To drain the freshwater tank, release the drain port on the side of the unit opposite the wastewater drain valve.

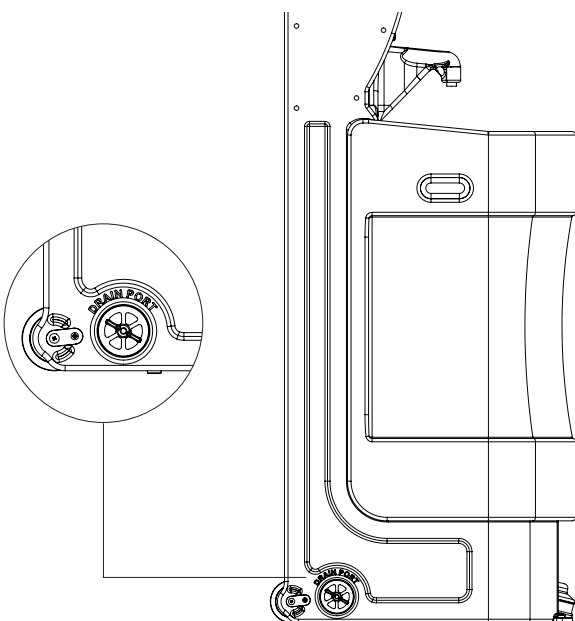

Draining the Wastewater Tank:

To drain wastewater, a standard garden hose can be attached (optional) to the threaded end of the wastewater valve on the side of the unit. By turning the valve left a quarter turn, the wastewater tank will begin draining. (Check local ordinance for wastewater disposal.)

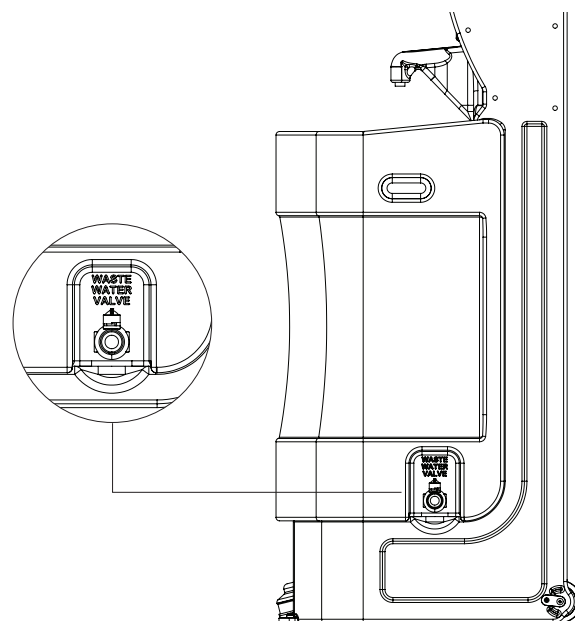

II. Usage Guidelines (continued)

Soap Dispensers

- Use access key to unlock and remove lid. If access key is lost, use a flathead screwdriver to unlock soap dispenser lid.
- Press the clip to remove the dispenser from the mounting plate.
- Four AA batteries (not included) are installed on the underside of the dispenser.

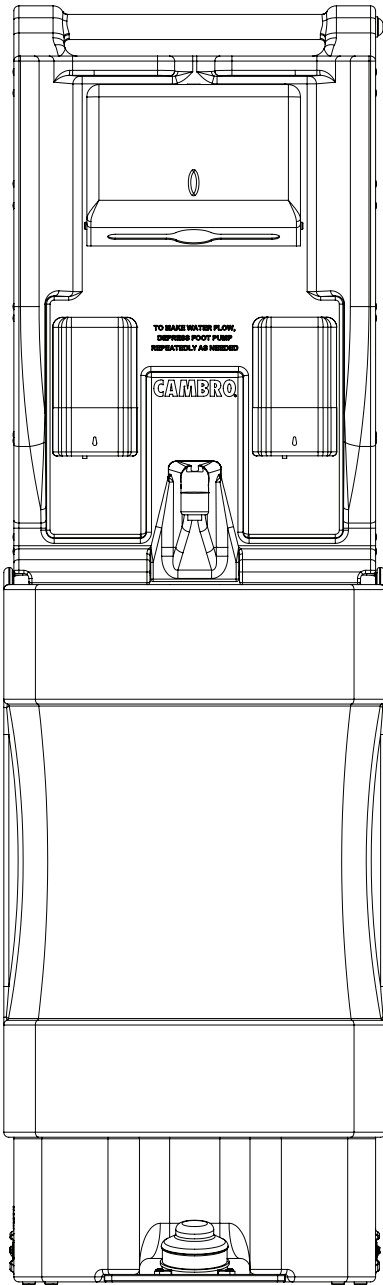

Unit weight (empty):
53.6 lbs. (24,3 kg).

Unit weight (full):
224.7 lbs. (101,9 kg).

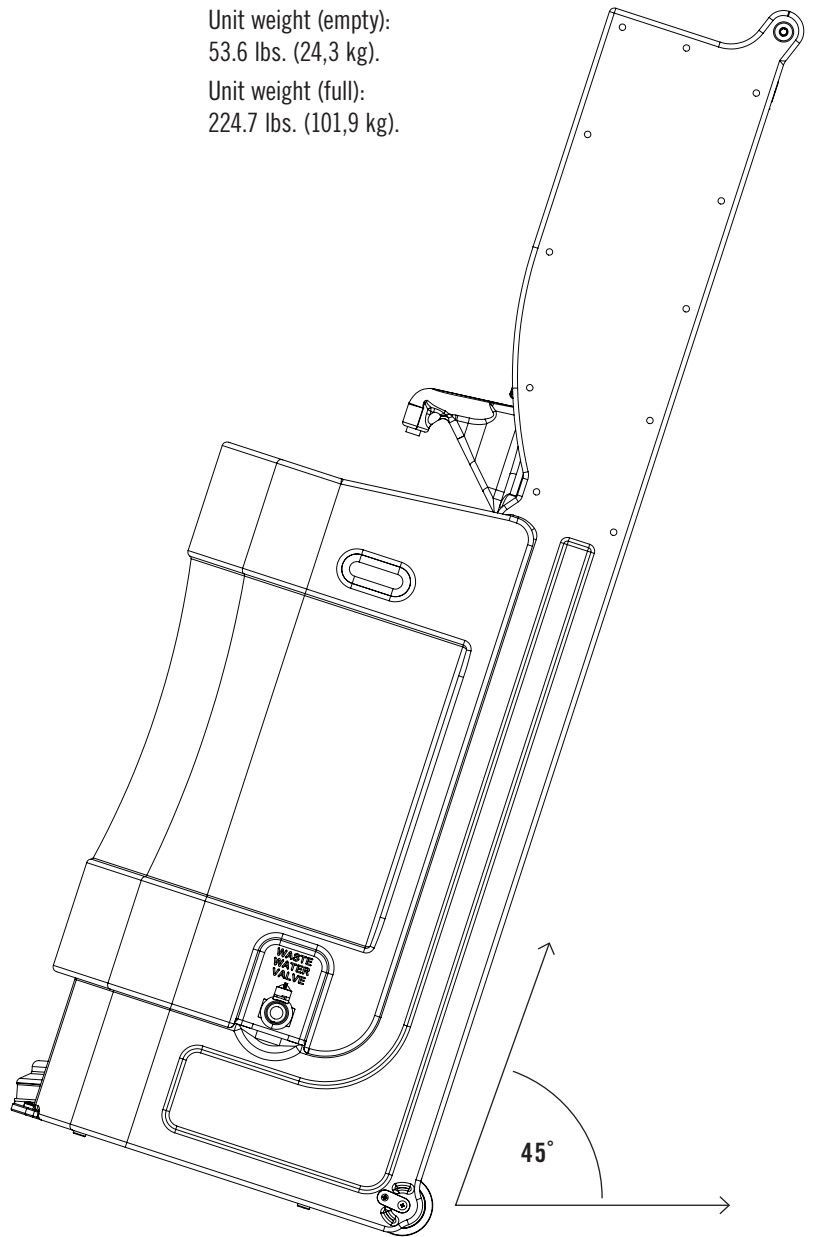

Note

Soap dispenser can leak from the top during transport. Recommend to transport with soap dispenser empty and/or do not tilt unit back more than 45 degrees to prevent soap spillage.

III. Care and Maintenance

Cleaning and Water Maintenance:

- Use a mild soap to clean all surfaces and component parts.

Cleaning for Storage

- Drain all water from the tanks.
- Flush tank with a solution of chlorine and water.
- Depress the foot pump to run the chlorine solution through the lines.
- Drain all water from the tanks and while the drains are open, continue to depress the foot pump to clear all of the liquids from the lines.

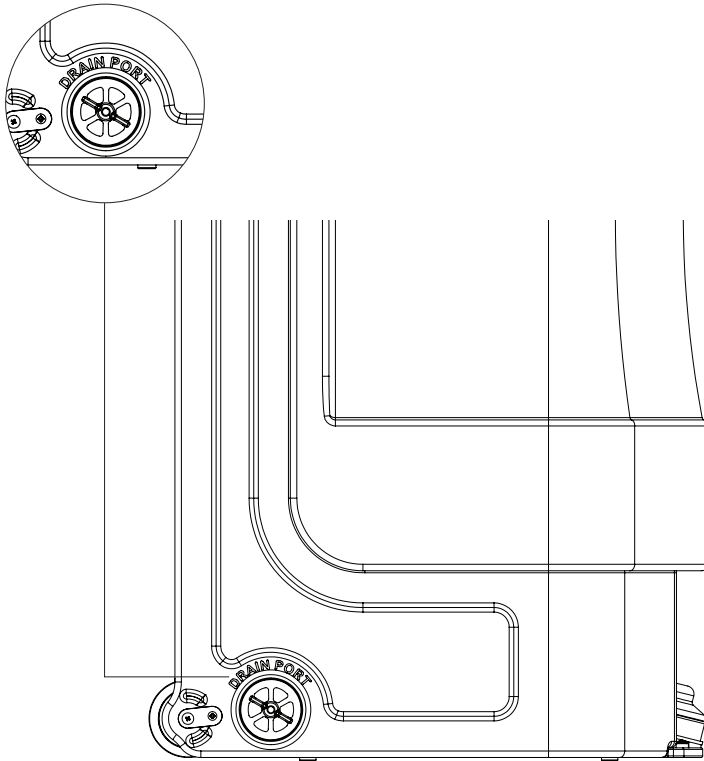

Short Term Storage:

- Keep the yellow plugs in. Plugs out will invite contamination.

Long Term Storage:

- Leave yellow plugs out to promote air circulation and complete drying of the tanks. Remove plug at the weep hole near top handle and tilt unit flat or even upside down to remove all excess water left in freshwater tank.

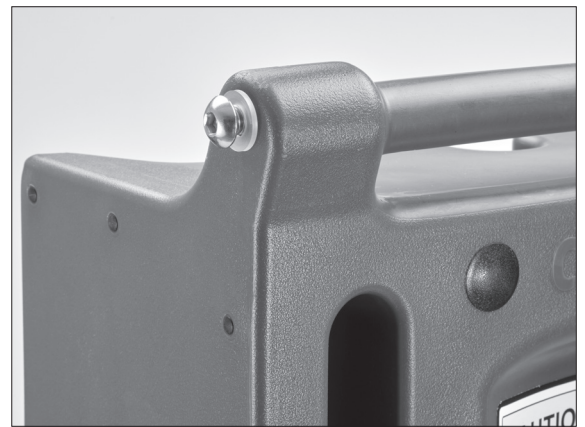
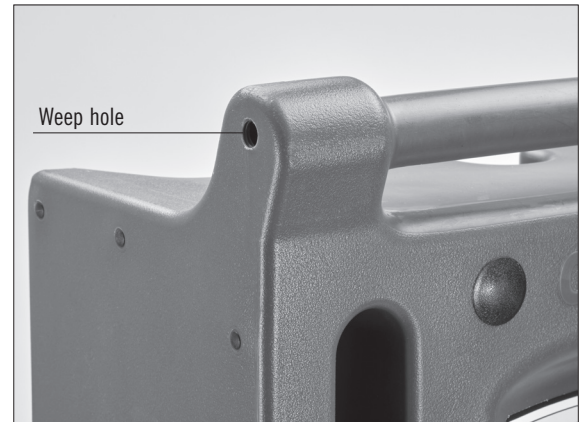

Removing the Wastewater Tank:

- Anchors on rear of unit must be unscrewed to remove the wastewater tank (if needed). Do not over tighten the anchors when reinstalling the wastewater tank.

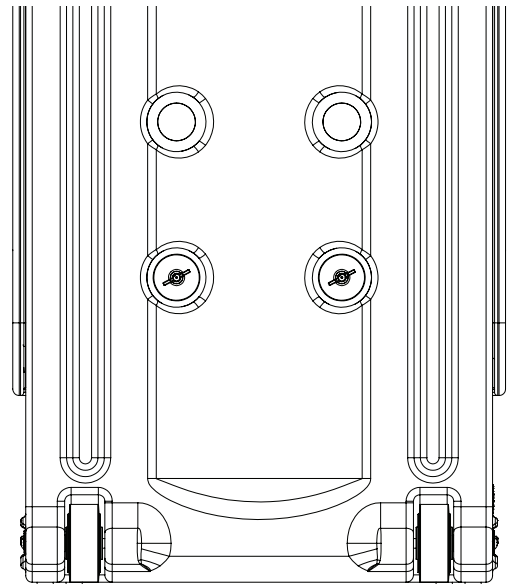

IV. Replacement Parts

Please visit www.cambro.com/parts for a complete list of replacement parts for the MHWS18.

TO ORDER REPLACEMENT PARTS:

- Call Cambro Customer Service at 800 833 3003
- From International markets, call 714 848 1555
- Email customerservice@cambro.com
- Call your local Cambro Representative or Distributor

V. Cambro Warranty and Product Liability

Cambro warrants to the original buyer that if a product proves defective:

1. Within 1 year from the date of manufacture, Cambro will replace the product free of charge; or,
2. After 1 year and up to 2 years from the date of manufacture, Cambro will grant a credit of 2/3 off replacement product; or,
3. After 2 years and up to 3 years from the date of manufacture, Cambro will grant a credit of 1/3".

RETURN POLICY: Cambro Manufacturing products cannot be returned without prior written factory authorization (**RMA**). The restocking charge is 15% plus any costs required to recondition the equipment. No returns accepted after 90 days from date of invoice. Electrical components returned are subject to inspection prior to credit being issued. Electrical components which have been installed by an operator or non-approved service agent are not returnable for credit.