



Juice Extractor



WARING COMMERCIAL
P.O. Box 3201
314 Ella T. Grasso Ave.
Torrington, CT 06790
www.waringproducts.com

015461 RV05 0601

IMPORTANT SAFEGUARDS

When using electrical appliances, basic safety precautions should always be followed, including the following:

1. **READ ALL INSTRUCTIONS.**
2. To protect against risk of electrical shock do not put motor base-housing, shown on page 2 of your manual, in water or other liquid.
3. Close supervision is necessary when any appliance is used by or near children.
4. Unplug from outlet when not in use, before putting on or taking off parts, and before cleaning.
5. Avoid contacting moving parts.
6. Do not operate any appliance with a damaged cord or plug or after the appliance malfunctions or has been dropped or damaged in any manner. Return appliance to the nearest authorized service facility for examination, repair or electrical or mechanical adjustment.
7. The use of any attachments not recommended or sold by the manufacturer may cause fire, electric shock or injury.
8. Do not use outdoors.
9. Do not let cord hang over edge of table or counter, or touch hot surfaces.
10. Always make sure juicer lid is secure beneath springs before motor is turned on. Do not loosen lid while Juice Extractor is in operation.
11. Be sure to turn switch to "OFF" position after each use of your Juice Extractor. Make sure the motor stops completely before disassembling.
12. Do not put your fingers or other objects into the Juice Extractor opening while it is in operation. If food becomes lodged in opening, use food pusher or another piece of fruit or vegetable to push it down. When this method is not possible, turn the switch to "OFF", unplug the unit and disassemble juicer to remove the remaining lodged food.

NOTE: A thermal protection device appears as a red button on the bottom of the machine. Should the machine overheat for any reason, this switch will cut off the electrical current and the machine will stop; thus saving the machine from possible damage or fire. To reset the machine, simply push the red button, and the machine will again function normally.

SAVE THESE INSTRUCTIONS

**For your record
please fill in
this information
for future use**

Name _____
 Serial No. _____
 Date of Purchase _____
 Purchased From _____
 Cat. No. _____

As you use your Waring® Commercial Juice Extractor, you will discover new combinations that you would like to share with others. We will welcome any delightful new discoveries that you happen to make.

1. 2/3 Carrot Juice with 1/3 of Celery. For improved flavor add a few drops of lemon juice.
2. 1/2 Carrot Juice – 1/2 Apple Juice.
3. 3/4 Carrot Juice – 1/4 Cabbage Juice.
4. 2/3 Celery Juice – 1/3 Apple Juice.
5. 5 oz. Carrot Juice – 2 oz. Cucumber Juice – 1 oz. Beet Juice.
6. 4 oz. Carrot Juice – 3 oz. Celery Juice – 1 oz. Parsley (or any leafy green).
7. 4 oz. Orange Juice – 4 oz. Grapefruit Juice – 1 oz. Lemon Juice.
8. 6 oz. Apple Juice – 8 oz. Carrot Juice – 2 oz. Spinach Juice.
9. 2 oz. Carrot Juice – 4 oz. Apple Juice – 2 oz. Cabbage Juice.
10. 7 oz. Celery Juice – 1 oz. Lemon Juice.
11. 4 oz. Apple Juice – 4 oz. Orange Juice.

USES OF PULP

With the Waring® Commercial Juice Extractor, Nothing is Wasted.

The pulp may be used for flavoring in Soups, Casseroles, Breads, Cakes, Salads, and Jello Molds. Many people also use the pulp as compost for Gardens, Shrubbery, Flowers and Plants.

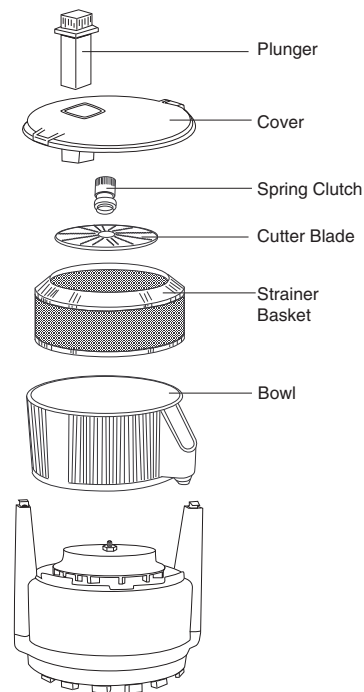

PARTS LIST

If for any reason parts are to be ordered, please do so by names as listed. Parts may be ordered from any Authorized Service Center. Be sure to give **Model and Serial number** from bottom of machine when ordering.

	5001C	6001C
Plunger	016126	016126
Cover	015170	015206
Spring Clutch	026093	026093
Cutter Blade	015180	015180
Strainer Basket	015174	015174
Bowl	015168	015205

For Service or Parts Send To:
 Waring Service Center
 P.O. Box 3201
 314 Ella T. Gasso Ave.
 Torrington, CT 06790
 1-800-269-6640
 or any Authorized Waring Service Center

CABBAGE JUICE

A, B, C, G, and U
Chlorine, Calcium, Sodium, and Iron

After washing, cut into wedges that can be fed into the juicer.

CELERY JUICE

A, B, E, and C
Potassium, Calcium, Sulphur

Separate stalks and push into juicer with leaf end first.

BEET JUICE

A, B, C, and G
Sodium, Iron, Calcium, Potassium, and Chlorine

Wash thoroughly, cut into sections to fit feeder chute. Beet tops may also be juiced. See instructions for leafy vegetable juices.

CUCUMBER JUICE

B, C, B2,
Potassium, Calcium, Sodium, Sulphur, and Chlorine

Wash thoroughly, quarter the cucumber lengthwise and use a slow even motion to feed. Peel if desired.

LEAFY VEGETABLE JUICE

A, B12, B6, C, and E

Parsley, Lettuce, spinach, Turnip Greens, Dandelion, Watercress, etc.

Wash thoroughly, then wrap in dry towel and refrigerate until they become crisp.

When ready for juicing, twist and roll into a small ball and use plunger to feed.

These should be juiced first when making a combination.

APPLE JUICE

A, B1, B2, and C
Magnesium, Iron, Silicon, Potassium, Phosphorus,
Sodium, Calcium, Sulphur, and Chlorine.

Wash thoroughly, it is not necessary to peel or core apples, but we do recommend removing the flower. Cut into sections to fit feeder chute. **Only hard, firm apples should be juiced.**

CITRUS JUICES

Oranges, Grapefruit, Lemons, etc.

Large source of Vitamin C, Pectin and Bioflavonoids, especially in white portion under peel.

For the juicing of any citrus items, the citrus attachment should be used.

NOTE: Very soft fruits and vegetables such as tomatoes, peaches, and grapes can be juiced; however, they should be alternately juiced with firmer fruits and vegetables and care should be taken in their selection (such as using seedless grapes and taking skins off peaches and tomatoes). Because of their softness, some vibration may occur.

SUGGESTIONS FOR JUICE COMBINATIONS

Many of our customers frequently request recipes and suggestions for tasty combinations of juices. We have found this very much a matter of individual taste and ideas of taste-tempting juice combinations vary considerably.

Most everyone enjoys the juices in their fresh form just as they come from the Juice Extractor. If this is not the case with you, you can combine different juices in proportions to suit your taste. After experimenting with different juices, everyone will find the right combinations that he enjoys.

Vegetable or fruit cocktails can be taken at any time. Nothing surpasses them for helping to quicken energy, and they are delicious nutritious drinks.

Following are tips on tasty combinations that are being used and recommended by many of our happy Juice Extractor users. For something new and exciting, you will want to try these recipes.

CONTENTS

Page	
1	Wonderful Nutritional Experience
2	Disassembly Instruction – Assembly Instructions
2	Cleaning Instructions
3	Important Juice Extractor Facts
3	Points on Juicing
3	Most Popular Juices – (Their Vitamin & Mineral Content and “How to Juice”)
4	Suggestions For Juice Combinations
5	Uses of Pulp
5	Parts & Service List

A WONDERFUL NEW NUTRITIONAL EXPERIENCE

Raw juices derived from fresh fruits and vegetables and invaluable as an aid in the maintenance of a balanced diet. Raw juice is highly assimilable and contains, in most natural and complete form, precious vitamins and minerals, bioflavonoids and enzymes. In addition, nutritional authorities state that raw juice is food in easily digested form.

Be sure to use you **Waring® Commercial Juice Extractor** daily, or as often as you can manage, in the manner recommended in this instruction manual.

Because of the cleansing and rebuilding properties contained in juices, it is recommended that you use juices in small amounts the first week and then gradually increase as you can comfortably enjoy them.

Vegetable juices can be mixed, but if fruit juices are added, do not use more than one kind. We recommend that fruit juices be taken alone, between meals, and at room temperature.

For further information on the consumption of juices we recommend that you visit your health food or book store and pick up the many juice books available on this subject.

The **Waring® Commercial Juice Extractor** is the result of years of intensive research and scientific developments, and we feel sure you will be delighted with its precision performance.

IMPORTANT: Juice Extractor should be unplugged from outlet when disassembling.

DISASSEMBLING

1. After removing your new Juice Extractor from the box, you may want to familiarize yourself with the parts by disassembling Juice Extractor and washing the top parts.
2. With Juice Extractor facing you (spout front), put your hands on both sides of the cover. Using the sidearms for leverage, push back with your left hand and pull forward with your right. This will disengage the cover from the spring clips and allow you to lift off the cover.
3. Looking into Juice Extractor remove spring clutch by unscrewing counterclockwise.
4. Lift out cutter blade.
5. Lift out strainer basket.
6. Lift off bowl.

ASSEMBLING INSTRUCTIONS

1. Place bowl on base housing and place spout facing front between the two raised projections.
2. Place basket inside the bowl over the hex nut. Be certain basket sits flat.
3. Place cutter blade inside basket with teeth up.
4. Tighten spring clutch finger tight or snug.
5. Place cover on bowl with feeder chute to right rear and turn it counter-clockwise to secure beneath spring clips.

CLEANING INSTRUCTIONS

1. Follow disassembling instructions.
2. Use cool or cold tap water when washing.
3. The **Plunger, Cover, Bowl and Spring Clutch** require only rinsing.
4. **Blade** should be washed under running water, using a stiff brush.
5. After removing most of the pulp from basket using a spoon or your hands, hold basket under running water while you brush the strainer holes from the outside. After the holes are clean, take a damp sponge or towel and wipe out the remaining particles.
6. Towel dry all parts and assemble - turn Juice Extractor on for few seconds -turn off - return to storage. Filters: paper filters which simplify the cleaning operation are available. Order 200 pack. Part number 501289.

NOTE: In case mineral stains appear after repeated use, soak the Top, Bowl, Basket, Cutter Blade and Spring Clutch overnight in cold water in which "Cascade" detergent (8 tablespoons to a gallon of water) has been dissolved.

Make sure all parts soaking are completely covered with water.

2.

IMPORTANT FACTS YOU SHOULD KNOW ABOUT YOUR JUICE EXTRACTOR

1. Your Waring® Commercial Juice Extractor has an induction motor and should never be oiled or lubricated.
2. All removable metal parts are dishwasher safe. Wash remaining parts by hand. Never dry ANY parts of your Juicer on the stove or in the oven.
3. Be sure basket and cutter blade are dry before using. The blade is designed with a floating action that allows blade to move independent of the basket: thus, a wet blade or basket would inhibit this flotation action.
4. When placing the cover on top of the machine, make sure the feeder chute is to the rear of the machine.
5. After you finish feeding the vegetables, allow machine to run for two to three minutes for maximum juice extraction.
6. The amount of juice you can make before emptying the basket depends on what you are juicing and the amount of juice it contains. For instance: Approximately 1 quart of carrot juice alone can be made at one time; or 1H quarts of carrot and celery mixed. Please do not overjuice.
7. For easier cleaning, Disposable Filters are available. (See Card Insert and Samples Enclosed.)

POINTS OF JUICING

As we pointed out in the introduction, the Waring® Commercial Juice Extractor is a precision machine and the following hints will help you obtain optimum performance. Vegetables should always be fresh and crisp. All fruits and vegetables should be fed down the feeder chute. Feed all vegetables in the largest pieces possible.



With hard fruits and vegetables (carrots, beets, celery, etc.), we recommend feeding with a hard, uneven, pulsing motion. With softer fruits and vegetables (apples, cucumbers), we recommend a slow, even feeding motion to allow the skins to be torn apart completely. The Waring® Juice Extractor is a centrifugal type juicer and by following the instructions above you can avoid having the juicer vibrate. However, if you do experience some vibration, the strainer basket has become imbalanced through overjuicing or improper introduction of food material. Stop juicing, and empty pulp.

MOST POPULAR JUICES

Their Vitamin & Mineral Content and "How to Juice"

We have listed some of the most popular fruits and vegetables used for juicing. Of course, in different areas you may have vegetables we have not listed, so please apply the following instructions to any similar fruit or vegetable.

CARROT JUICE A, B, C, and G

Potassium, Iron, Magnesium, Calcium, Manganese, Sodium, Silicon, and Iodine

Carrot Juice is the favorite of many and can be mixed with most any other juice to make a tasty blend. Carrots should be scrubbed with a nylon brush. Do not peel or cut into small pieces. Leave Carrots whole and cut them only if they are too large to fit into the feeder chute. For best juice extraction, carrots should be juiced at room temperature rather than cold. Carrot Juice should be consumed as soon as it is made, or can be stored in the refrigerator for use the same day. By adding a few drops of orange or lemon juice, it will keep its color much longer.

3.