

Project: _____

Item No.: _____

Quantity: _____

DROP-IN SERVING EQUIPMENT



COLD PAN

Refrigerated
with Side Coils
Self-Contained

- WCMD-C-1
- WCMD-C-2
- WCMD-C-3
- WCMD-C-4
- WCMD-C-5
- WCMD-C-6

SPECIFICATIONS

TOP: Constructed of 18 gauge, type 304 stainless steel, die stamped with a raised perimeter bead. There shall be a solid vinyl gasket under the beaded edge to form a seal to the counter top, thus preventing seepage or marring of the counter top. Embossed mounting lugs are provided along the inner surface of the top to hold the removable separator channels in place.

LINER: The inner liner shall be 18 gauge, type 304 stainless steel, one piece construction, all welded, ground and polished to a uniform finish. All corners are covered with a minimum 1/4" radius. **The liner has copper tubing firmly soldered to the exterior bottom and all sides.** A 3/4" dia. drain with strainer, 4" PVC nipple, and valve is provided.

INSULATION: The pan is fully insulated with high density polystyrene, 1/2" thick on all sides, 1-1/2" thick on the bottom and enclosed with a 22 gauge galvanized steel outer case.

REFRIGERATION SYSTEM: The compressor housing shall be fabricated from 14 gauge galvanized and bolted to the base of the unit. A fully self-contained condensing unit is provided with a hermetically sealed compressor and a thermostat control. The system is fully charged with CFC free refrigerant and ready to operate.

NOTE: Proper ventilation must be provided in counter.

ELECTRICAL: The unit will be wired for 15 amps., 120 volt, single phase operation with an on/off thermostat switch and pilot light. A 6' long, 3-wire cord and plug (NEMA 5-15P) will be provided.

Specifications subject to change without notice.

STANDARD FEATURES

- Accommodates your deepest pan or insert - 9-3/4" deep
- Refrigerated copper tubing around the bottom and all sides - meets your toughest health department standards
- Fully insulated for maximum efficiency and energy savings
- Factory applied gasket - makes installation a snap and seals units to the counter top, thus eliminating seepage
- Accommodates standard 12" X 20" pans with the use of separator channel(s), or fractional size pans with the use of optional adapter bars
- 1-Year Parts & Labor Warranty
- NSF Certified; UL Recognized

ACCESSORIES

- **5YW** - 5-Year Compressor Warranty
- **WFB** - Stainless steel perforated false bottom
- Stainless Steel adapter bars (pg DI-51-52)
- Stainless Steel adapter plates (pg DI-51-52)
- **CP** - Cover Plate with handles, S/S
- **2060-1** - Condensate Evaporator
- **RS** - Remote on/off switch for counter mounting
- **RDVE** - Rear Drain Valve Extension
- * **220 Volt - 50 Cycle** Compressor

These units have not been performance tested for use with potentially hazardous foods, and must be used with ice.

* Units with these accessories are not currently UL listed.

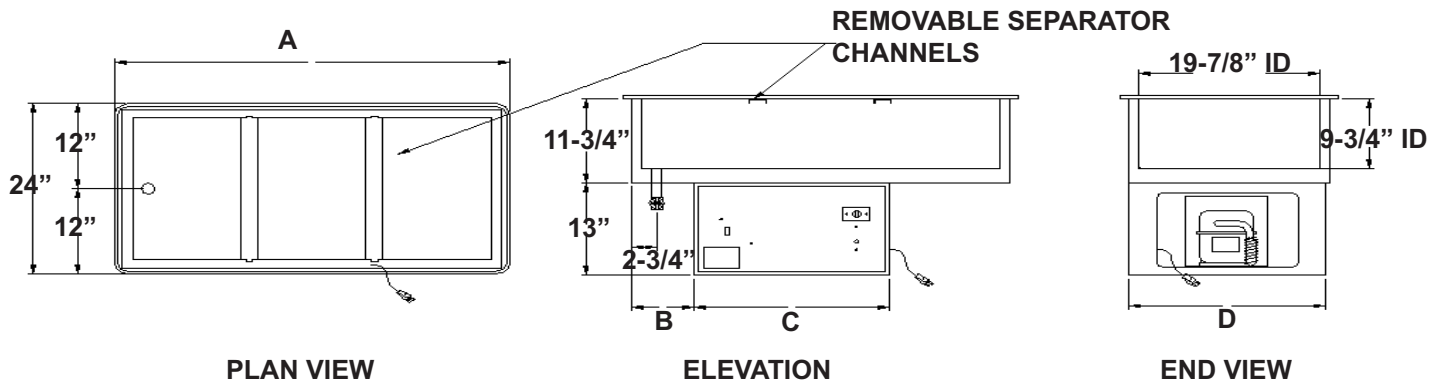

MODEL	PAN OPENINGS	PAN SIZE	"A"	ELECTRICAL CHARACTERISTICS	CUT-OUT REQUIRED	SHIP WT. (LBS.)
WCMD-C-1	1	19-7/8" X 11-3/4" X 9-3/4" (50.4 X 29.8 X 24.7cm)	16" (40.6cm)	2.4 amps. - 120V - 1/5HP	22-1/4" X 14-1/4" (56.5 X 36.1cm)	133 (60.3kg)
WCMD-C-2	2	19-7/8" X 25-1/2" X 9-3/4" (50.4 X 64.7 X 24.7cm)	29-3/4" (75.2cm)	3.9 amps. - 120V - 1/5HP	22-1/4" X 28" (56.5 X 71.1cm)	184 (83.4kg)
WCMD-C-3	3	19-7/8" X 39-1/4" X 9-3/4" (50.4 X 99.6 X 24.7cm)	43-1/2" (110.4cm)	3.9 amps. - 120V - 1/5HP	22-1/4" X 41-3/4" (56.5 X 106cm)	212 (96.1kg)
WCMD-C-4	4	19-7/8" X 53" X 9-3/4" (50.4 X 134.6 X 24.7cm)	57-1/4" (145.4cm)	6.8 amps. - 120V - 1/4HP	22-1/4" X 55-1/2" (56.5 X 140.9cm)	231 (104.7kg)
WCMD-C-5	5	19-7/8" X 66-3/4" X 9-3/4" (50.4 X 169.5 X 24.7cm)	71" (180.3cm)	9.8 amps. - 120V - 1/3HP	22-1/4" X 69-1/4" (56.5 X 175.8cm)	271 (122.9kg)
WCMD-C-6	6	19-7/8" X 80-1/2" X 9-3/4" (50.4 X 204.4 X 24.7cm)	84-3/4" (215.2cm)	9.8 amps. - 120V - 1/3HP	22-1/4" X 83" (56.5 X 210.8cm)	336 (152.4kg)

	B	C	D
WCMD-C-1	3-7/8" (9.8cm)	18" (45.7cm)	13-3/4" (34.9cm)
WCMD-C-2	5-5/8" (14.2cm)	21-1/2" (54.6cm)	21-5/8" (54.9cm)
WCMD-C-3	7" (17.7cm)	21-1/2" (54.6cm)	21-5/8" (54.9cm)
WCMD-C-4	7" (17.7cm)	21-1/2" (54.6cm)	21-5/8" (54.9cm)
WCMD-C-5	7" (17.7cm)	21-1/2" (54.6cm)	21-5/8" (54.9cm)
WCMD-C-6	7" (17.7cm)	21-1/2" (54.6cm)	21-5/8" (54.9cm)

REMOTE REFRIGERATION MODEL	LESS COMP. SHIP WT. (LBS.)
WCMD-CX-1	92 (41.7kg)
WCMD-CX-2	143 (64.8kg)
WCMD-CX-3	171 (77.5kg)
WCMD-CX-4	184 (83.4kg)
WCMD-CX-5	225 (102kg)
WCMD-CX-6	290 (131.5kg)

WCMD-CX - REFRIGERATED COLD PAN WITHOUT COMPRESSOR

Units include Refrigerated Cold Pan, Thermo stat, Cap Tube & Drier (for hook up in field by others)

COMPRESSORS FOR REMOTE INSTALLATIONS

2029 - 1/5 HP for WCMD-CX-1, 2, & 3
2029-1 - 1/4 HP for WCMD-CX-4
2029-2 - 1/3 HP for WCMD-CX-5 & 6