

EXPLODED VIEW - WEDGEMASTER® ~ MODELS 606N, 808N, 808SG

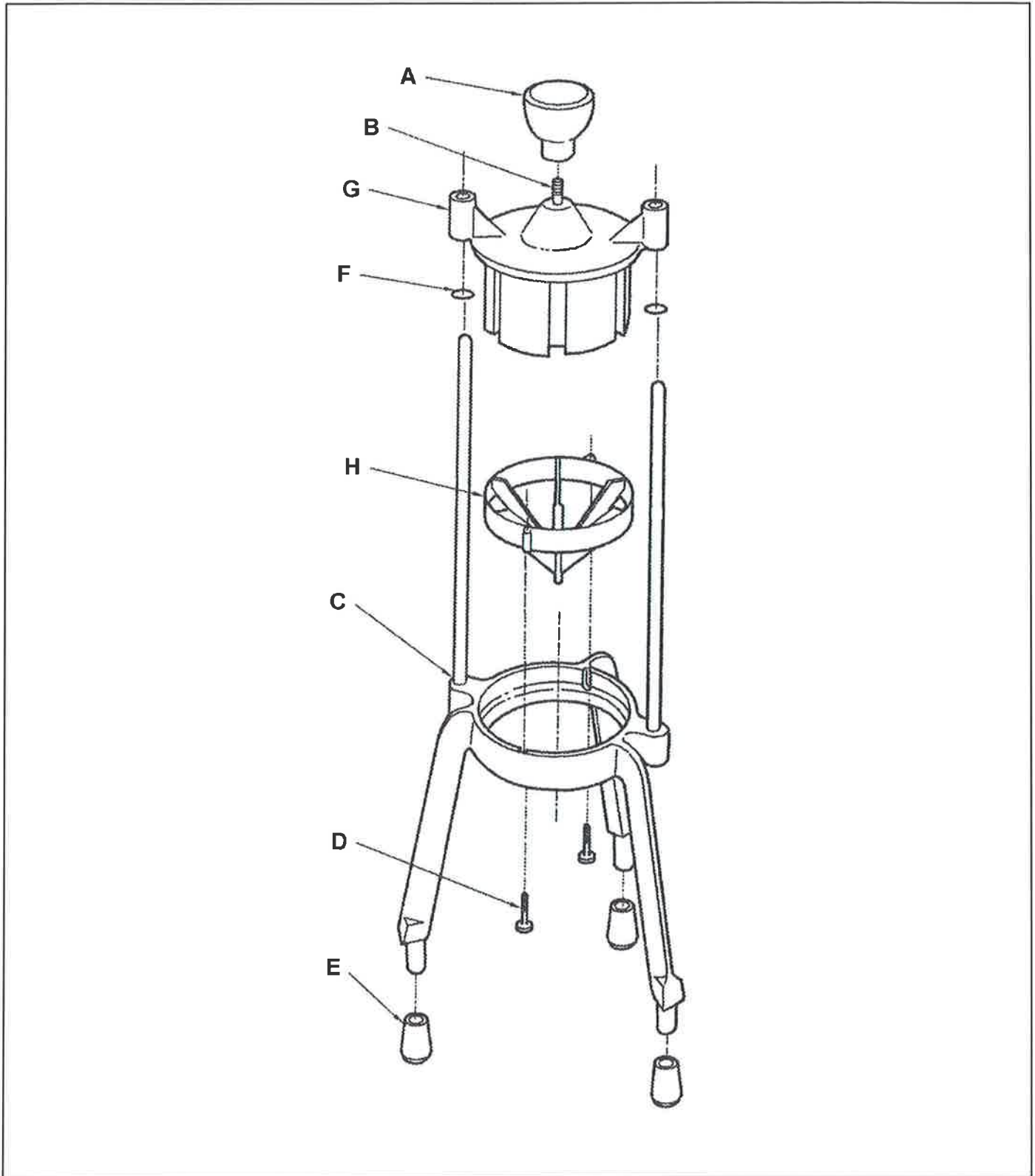

ENGLISH



## TROUBLESHOOTING

If the equipment no longer processes food cleanly or without damage to the food product, the blades could be dull and be in need of replacement. Broken, bent, or nicked blades must be replaced.

Problem	It might be caused by	Course of Action
Broken Blade.	Blades were dull.	Pre-score whenever possible to avoid undue shock and stress to blades Replace the blade assembly.

## SERVICE AND REPAIR

Please contact the qualified professional repair service listed below.

**VOLLRATH Induction Repair Service • 1-800-825-6036 (USA) or [www.vollrathco.com](http://www.vollrathco.com)**

When contacting the Authorized Professional Service Center, please be ready with the model number, serial number, and proof of purchase showing the date the equipment was purchased.

## SPARE PARTS LIST - WEDGWMMASTER® ~ MODELS 606N, 808N, 808SG

LETTER	PART NUMBER.	DESCRIPTION
A	0304	Red Knob Handle
B	2321	Aluminum Nipple
C	301	Base Housing & Rod Assembly
D	302	Blade Screw
E	303	Rubber Foot
F	305	"O" Ring
G	316	Head Assembly, Wedge Master, 6-Section
	318	Head Assembly, Wedge Master, 8-Section
	326	Head Assembly, Core Master, 6-Section
	328	Head Assembly, Core Master, 8-Section
H	306	Blade Assembly, Wedge Master, 6-Section
	308	Blade Assembly, Wedge Master, 8-Section
	336	Blade Assembly, Core Master, 6-Section
	338	Blade Assembly, Core Master, 8-Section
Not Shown		Safety Guard

