



Outperform every day.™

Operator's Manual

Conveyor Toasters, 350-1000 Slices Per Hour

Models JT2, JT2H, JT3, JT3H

Thank you for purchasing this Vollrath equipment. Before operating the equipment, read and familiarize yourself with the following operating and safety instructions. **SAVE THESE INSTRUCTIONS FOR FUTURE REFERENCE.** Save the original box and packaging. Use this packaging to ship the equipment if repairs are needed.

SAFETY PRECAUTIONS

To ensure safe operation, read the following statements and understand their meaning. This manual contains safety precautions which are explained below. Please read carefully.

WARNING

Warning is used to indicate the presence of a hazard that will or can cause severe personal injury or death.

CAUTION

Caution is used to indicate the presence of a hazard that will or can cause minor or major personal injury if the caution is ignored.

NOTICE: Notice is used to note information that is important but not hazard-related.

To reduce risk of injury or damage to the equipment

- Plug only into grounded electrical outlets matching the voltage on the rating plate.
- Use this equipment in a flat, level position.
- Unplug equipment and let it cool before cleaning or moving. Equipment remains hot after it is turned off.
- Unplug when not in use.
- Keep equipment and power cord away from open flames, electric burners or excessive heat.
- Do not operate unattended.
- Closely supervise equipment operating in public areas and/or around children.
- Do not operate if equipment has been damaged or is malfunctioning.

FUNCTION AND PURPOSE

This equipment is intended to toast bread products. It is intended for use in commercial foodservice operations only. It is not intended for household, industrial or laboratory use.

CLEARANCE AND ENVIRONMENT REQUIREMENTS

Do not place toaster on surfaces or near walls, partitions or kitchen furniture unless they are made of non-combustible material or clad with non-combustible heat-insulating material. Toasters must not be used near or below curtains and other combustible materials.

Do not place the toaster adjacent to a heat producing appliance.



Item No.	Model	Description
CT4-120450	JT2	120V, 450 Slices Per Hour
CT4-208800		208V, 800 Slices Per Hour
CT4-220800		220V, 800 Slices Per Hour
CT4-240800		240V, 800 Slices Per Hour
CT4H-120300	JT2H	120V, 300 Slices Per Hour, High Clearance
CT4H-208550		208V, 550 Slices Per Hour, High Clearance
CT4H-220550		220V, 550 Slices Per Hour, High Clearance
CT4H-240550		240V, 550 Slices Per Hour, High Clearance
CT4-2081000	JT3	208V, 1000 Slices Per Hour
CT4-2201000		220V, 1000 Slices Per Hour
CT4-2401000		240V, 1000 Slices Per Hour
CT4H-208950	JT3H	208V, 950 Slices Per Hour, High Clearance
CT4H-220950		220V, 950 Slices Per Hour, High Clearance
CT4H-240950		224V, 950 Slices Per Hour, High Clearance

SET UP

1. Place the toaster on a hard, flat, stable surface.
2. Turn the toaster on it's side with the bottom facing you.
3. Install the feet.

NOTICE: Feet must be installed. Failure to install the feet will restrict airflow and cause the toaster to overheat.

4. Install the collection pan by placing the back edge of the pan on the lip at the back of the toaster. Line up the hole in the pan with the screw. Tighten the screw to secure the collection pan.

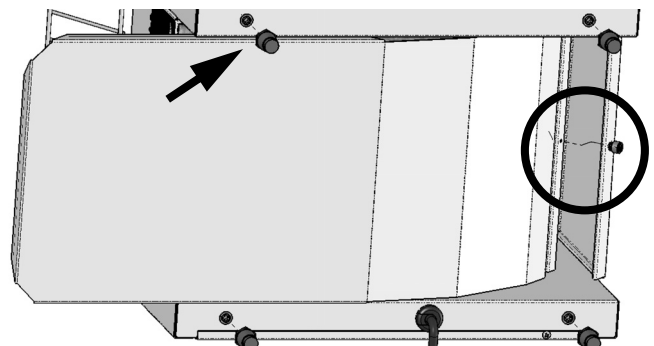

Register your product at Vollrath.com/registration and become eligible to win a free 10" Vollrath Tribute® fry pan.

BEFORE FIRST USE

1. Clean the toaster. See "Daily Cleaning" on page 3.
2. Insert the crumb tray. Make sure the feed ramp is placed in the up position.

FEATURES

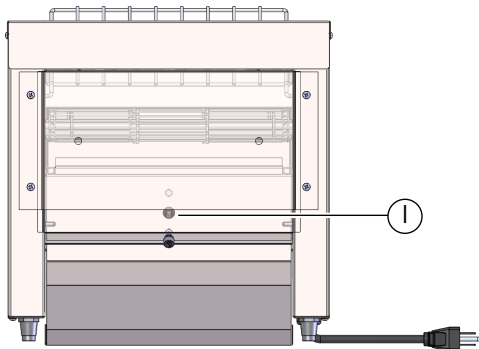
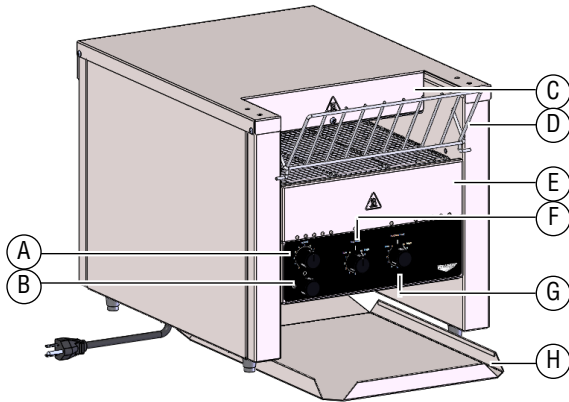

Back View

A Conveyor Speed Control Knob

B Power Knob

| Full Power - maximum heat

○ Off

⏻ Standby - reduces electrical consumption by 75%.

C Heat Shield - Adjustable on the high-clearance toasters

D Feed Ramp

E Crumb Tray

F Top Heat Control Knob

G Bottom Heat Control Knob

H Collection Pan

I Reset Button (Reference only. Access is via the front of the toasters. See page 3.)

OPERATION



CAUTION

Burn Hazard

Do not touch the equipment while it is heating or operating. Hot surfaces can burn skin.

NOTICE: The crumb tray must be installed in the toaster during operation. Failure to install the crumb tray will cause the toaster to overheat.

Tips

Bread Product	Suggestions
Bagels, wheat or rye bread or products with high moisture content.	Use a slower conveyor speed.
Buttered or coated, such as pastries	Not recommended.
Frozen	Must be thawed before toasting.

Preheat

1. Plug the toaster into a grounded electrical outlet that matches the rating on the name plate found on the side of the toaster.
NOTICE: Using a voltage other than the nameplate rated voltage will cause damage to the unit. Incorrect voltage, modification to the power cord or electrical components can damage unit and will void the warranty.
2. Toasters with an adjustable heat shield: Adjust the heat shield so the tallest bread product can pass below it. Excess space above the product will create heat loss and may reduce performance.
3. Rotate the power knob to the full power position (I).
4. Set the conveyor speed control knob to 7.
5. Rotate the top and bottom heat control knobs to high.
6. Wait 5 minutes for the toaster to preheat.

Test

1. Adjust the settings for the product to be toasted. See the Tips chart at the top of this page. Test the settings by placing a sample of the bread items to be toasted onto the feed ramp. Place bagels or buns onto the feed ramp with the cut side facing up.

For One-Sided Toasting, Set:

TOP heat control to the desired setting.

BOTTOM heat control to the OFF position.

2. Evaluate the results.

Toast

1. Adjust the top and bottom heat control settings and conveyor as needed for even toasting on each side of the bread product. Allow time for the toaster to adjust to new heat settings before placing bread on the conveyor.
2. For best performance do not overload the toaster. Wait a few seconds before loading a second row of bread into the toaster.

If a Bread Item Becomes Stuck

1. Rotate the power knob to the OFF position (O) and unplug the toaster.
2. Let the toaster cool completely.
3. Use a tong to remove the bread item. Take care to not bump the glass heating elements above and below the conveyor.

CLEANING

	WARNING
	Electrical Shock Hazard Do not spray water or cleaning products. Liquid could contact the electrical components and cause a short circuit or an electrical shock.

	CAUTION
	Burn Hazard Allow equipment to cool before moving or cleaning.

NOTICE: Do not use abrasive materials, scratching cleansers or scouring pad to clean the exterior of the equipment. These can damage the finish.

Daily Cleaning

1. Rotate the power knob to the OFF position (O) and unplug the toaster.
2. Let the toaster cool completely.
3. Slightly dampen a soft cloth with a warm water.
4. Use the dampened cloth to clean the exterior of the toaster, the air intake under the toaster, the feed ramp, and collection tray.

Clean the Conveyor

1. Plug in the toaster.
2. Rotate the power knob to the ON position (I).
3. Rotate the conveyor speed knob to 10.
4. Press and hold a heat resistant (steel wool, metal wire brush, etc) abrasive pad or brush against the conveyor. Move the pad or brush back and forth (left to right) across the conveyor to remove food debris.
5. Empty and clean the crumb tray.

PREVENTATIVE MAINTENANCE

Contact an authorized service agent for a professional cleaning of the components.

TROUBLESHOOTING

Problem	Might be Caused By	Course of Action
Toaster does not heat and the conveyor belt does not move.	Toaster is not plugged in.	Plug in the toaster.
	Power knob setting is incorrect.	Rotate the power knob to full power.
	The wall breaker may be tripped.	Reset the breaker.
	The reset may be tripped.	Look under the toaster to see if an object is preventing the fan blades from turning. <ol style="list-style-type: none"> 1. Rotate the heat control knobs to the OFF position. 2. Rotate the power knob to the OFF (O) position. 3. Unplug the toaster. 4. Wait 30 minutes for the toaster cool. 5. Remove the object. 6. Plug in the toaster. 7. Rotate the power knob to the ON (I) position. 8. Press the reset button.
		
		9. If the problem persists call Vollrath Technical Services.

TROUBLESHOOTING (CONTINUED)

Problem	Might be Caused By	Course of Action
		Inspect the fan blades to see if they are dirty. 1. Rotate the heat control knobs to the OFF position. 2. Rotate the power knob to the OFF (O) position. 3. Unplug the toaster. 4. Wait 30 minutes for the toaster cool. 5. Clean the fan blades. 6. Plug in the toaster. 7. Rotate the power knob to the ON (I) position. 8. Press the reset button. 9. If the problem persists call Vollrath Technical Services.
Toaster heats and the conveyor belt does not move.	There may be a problem with the motor/speed control or drive chain.	Contact Vollrath Technical Services.
Top or bottom heater tubes do not heat.	One or more heater tubes may have burned out. There may be a problem with the top or bottom heat switch.	Contact Vollrath Technical Services.
Toaster repeatedly overheats.	The crumb tray may not be installed.	Verify the crumb tray is installed.
	The fan may be dirty.	Verify the fan blades are clean.
	There may be a problem with the fan.	Run the toaster for 10 minutes. If the fan does not run, contact Vollrath Technical Services.
The fan is not running.	There may be a problem with the fan or fan switch.	Run the toaster for 10 minutes. If the fan does not run, contact Vollrath Technical Services.
The toaster is turned off and the fan is running.	Normal operation. The fan turns on as needed to cool the toaster.	—

SERVICE AND REPAIR

When under warranty, repair is available for this product. To begin the process:

1. Contact Vollrath Technical Services at 1-800-309-2250. Please be ready with the item number, model number and serial number. You can find this information on the nameplate located on the side or back of the equipment. Also please provide a proof of purchase indicating the date the equipment was purchased.
2. A technical services representative will help you troubleshoot the problem over the phone.
3. If the representative determines the issue requires professional service, he or she will help you locate an authorized service center.
4. Contact the authorized service center to make arrangements for the repair. Vollrath will cover the cost to repair and/or replace defective parts within the equipment warranty period.

WARRANTY STATEMENT FOR THE VOLLRATH CO. L.L.C.

The Vollrath Company LLC warrants the products it manufactures or distributes against defects in materials and workmanship as specifically described in our full warranty statement. In all cases, the warranty runs from the date of the end user's original purchase date found on the receipt. Any damages from improper use, abuse, modification or damage resulting from improper packaging during return shipment for warranty repair will not be covered under warranty.

The warranty does not apply to products purchased for personal, family or household use, and The Vollrath Company LLC does not offer a written warranty to purchasers for such uses.

Warrantied Parts: The warranty period is 2 years parts, 1 year labor.

Heater Tubes: The warranty period is 1 year, including labor. Heater tube glass damage is not covered by this warranty.

For complete warranty information, product registration and new product announcements, visit www.vollrath.com.



Outperform every day.™

www.vollrath.com

The Vollrath Company, L.L.C.

1236 North 18th Street
 Sheboygan, WI 53081-3201 U.S.A.
 Main Tel: 800.624.2051 or 920.457.4851
 Main Fax: 800.752.5620 or 920.459.6573
 Customer Service: 800.628.0830
 Canada Customer Service: 800.695.8560

Technical Services
techservicereps@vollrathco.com
 Toasters: 1-800-309-2250
 All Other Products: 800.628.0832