

# Operator's Manual



## EaziClean® Can Opener Premium™ Can Opener



Product Number	Description
BCO-2000	EaziClean® 16" Bar Length, 1" Gear
BCO-3000	EaziClean® 25" Bar Length, 1" Gear
BCO-5000	EaziClean® 16" Bar Length, 1-1/2" Gear
BCO-6000	EaziClean® 25" Bar Length, 1-1/2" Gear
BCO-7000	EaziClean® 25" Bar Length, 1-1/2" Gear
BCO-1	Preimum™ 16" Bar Length, 1" Gear

Thank you for purchasing this Vollrath Food Processing Equipment. Before operating the equipment, read and familiarize yourself with the following operating and safety instructions. **SAVE THESE INSTRUCTIONS FOR FUTURE REFERENCE.** Save the original box and packaging. Use this packaging to ship the equipment if repairs are needed.



## SAFETY PRECAUTIONS

To ensure safe operation, read the following statements and understand their meaning. This manual contains safety precautions which are explained below. Please read carefully.

### WARNING

Warning is used to indicate the presence of a hazard that *can* cause severe personal injury, death, or substantial property damage if the warning is ignored.

### CAUTION

Caution is used to indicate the presence of a hazard that *will* or *can* cause *minor* personal injury or property damage if the caution is ignored.

### NOTE

Note is used to notify people of installation, operation, or maintenance information that is important but not hazard-related.

### For Your Safety!

These precautions should be followed at all times. Failure to follow these precautions could result in injury to yourself and others or damage the equipment.

To reduce risk of injury or damage to the unit:

- Check machine before each use to insure the equipment is clean.
- Check for broken, nicked or dull blades and if found, replace blade.

## FUNCTION AND PURPOSE

Easily pierce and safely open cans.

## BASE INSTALLATION

Installing the can opener base:

1. Choose a convenient location with a firm work surface (C) and install the base (A) securing with the hardware (B) provided. See Figure 1. On thin gauge work surface we suggest you fit a spacer plate underneath. This will prevent the flexing of the work surface and possible spillage of can contents during opening.

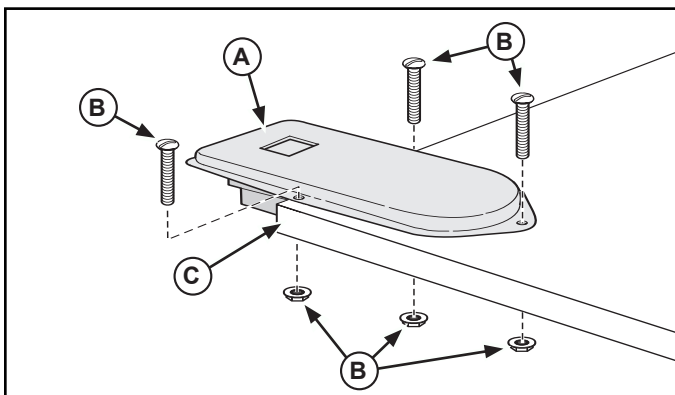

Figure 1. Base to Work Surface Installation.

## OPERATION

Prior to first use, it is important to clean the unit. Wash the unit with warm soapy water and rinse thoroughly to remove the thin protective oil film.

2. Place the can opener bar (A) into the base (B) as shown in Figure 2.

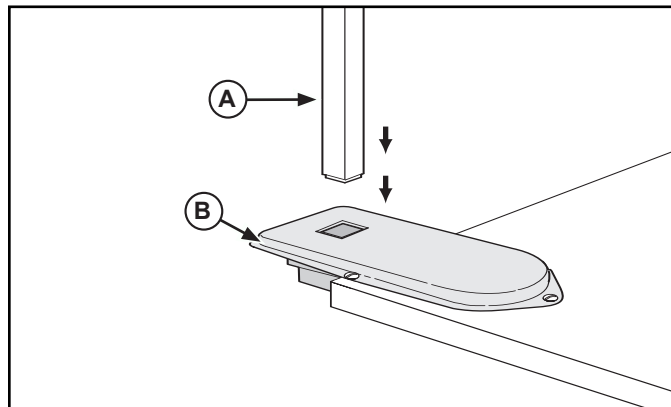

Figure 2. Bar into Base Installation.



### WARNING

**Sharp Blade Hazard.**  
Blades are sharp and can cause cuts.

To avoid injury from sharp blades, handle with caution. Only trained personal should operate equipment or perform maintenance.

3. Move the handle (A) to the UP position as shown. Place the can (B) against the bar (C). Using a swift downwards movement, punch the blade (D) into the can lid. See Figure 3.

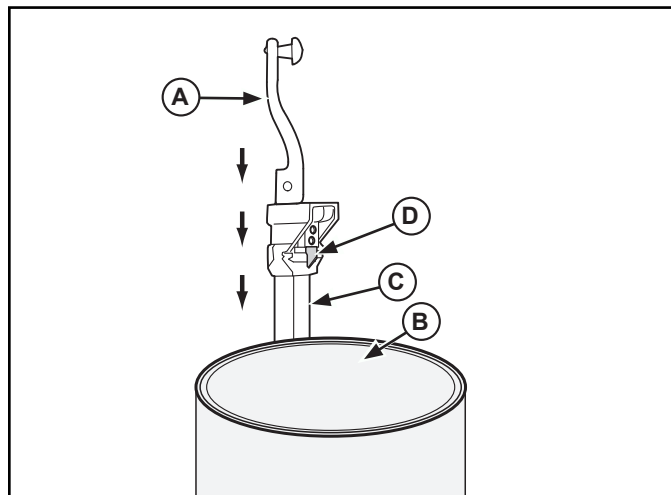

Figure 3. Punching the Blade into the Can.



4. Lower the handle (A) to the 90° or DOWN position. See Figure 4.

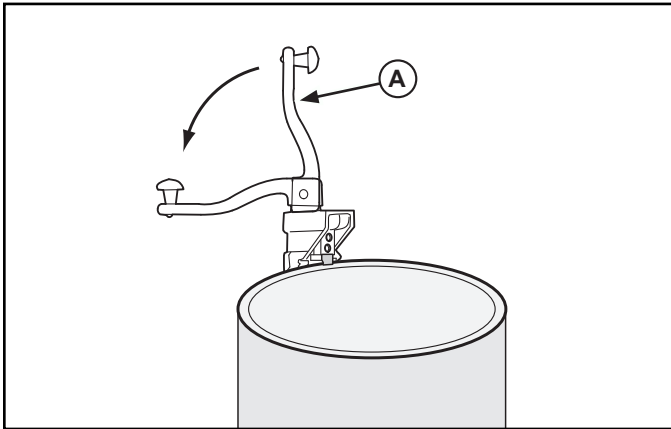

Figure 4. Lowering the Handle.

5. Crank the handle (A) in a clockwise direction to open the can. See Figure 5.

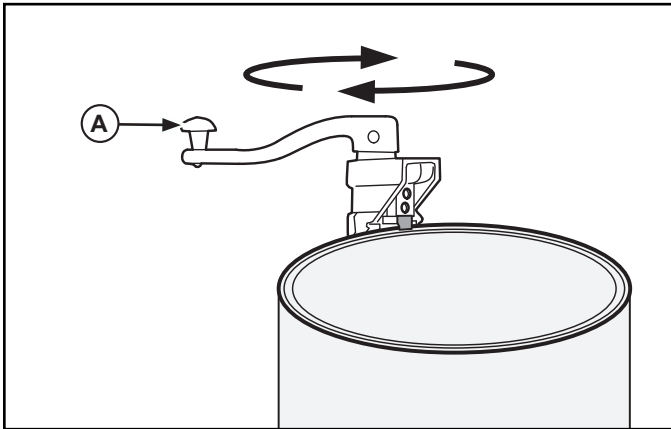

Figure 5. Rotating the Handle.

6. Lift the handle (A) to the UP position. See Figure 6.

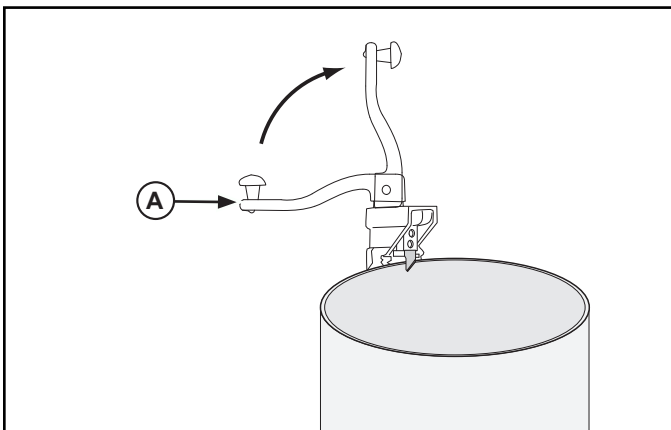

Figure 6. Raising the Handle.

7. Put the handle (A) to the vertical position. Raise the handle (A) and bar (B) up. Remove the can (C) from the can opener base. See Figure 7.

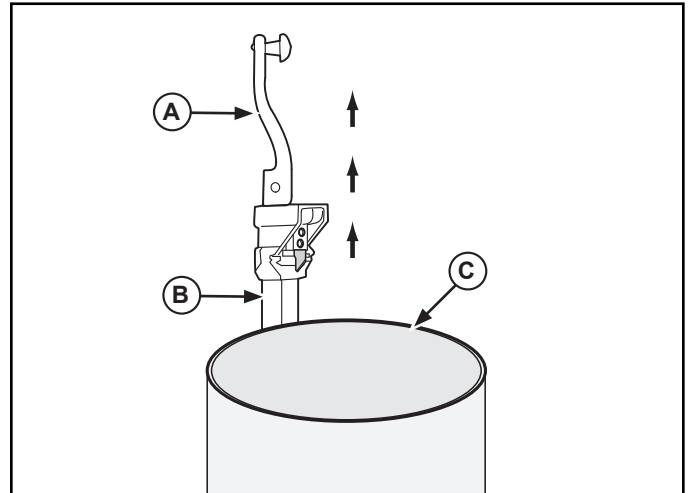

Figure 7. Removing the Bar, Handle and Can.

### CLEANING

To maintain the appearance and increase the service life, clean your unit daily.

1. Rinse or spray off the can opener thoroughly with HOT water and a bristle brush. Remove the blade cartridge on EaziClean® models for better cleaning. See REPLACING the Blade section of this manual for details.
2. After cleaning, let the unit air dry.

### NOTE:

**Food acids will make blade dull and corrode the metal. Always clean this food preparation equipment immediately after every use.**

3. Visually check the blade regularly to see that is in good condition (A). If the blade has a nick (B), discard and replace with a new blade. See Figure 8.

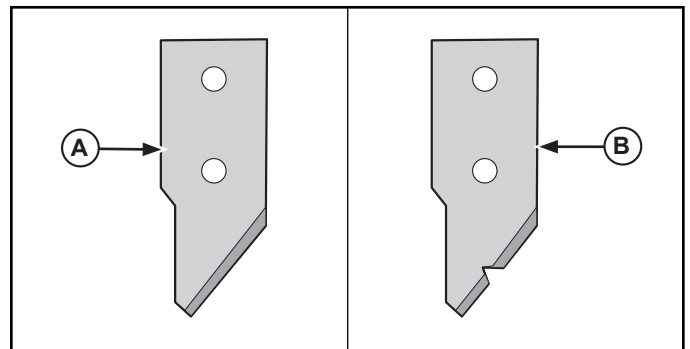

Figure 8. Blade Inspection.

4. Visually check the gear teeth for wear. Can opener will slip during operation if the gear is worn.

## REPLACING THE BLADE

	<b>WARNING</b>
	<b>Sharp Blade Hazard.</b> Blades are sharp and can cause cuts.

To avoid injury from sharp blades, handle with caution. Only trained personal should operate equipment or perform maintenance.

Wash new parts with warm, soapy water and rinse thoroughly to remove the thin protective oil film. Keep the sharp edge away from you when handling blades.

To remove the blade cartridge and change the blade on EaziClean® models:

1. Move the handle (A) to the position as shown in Figure 9.

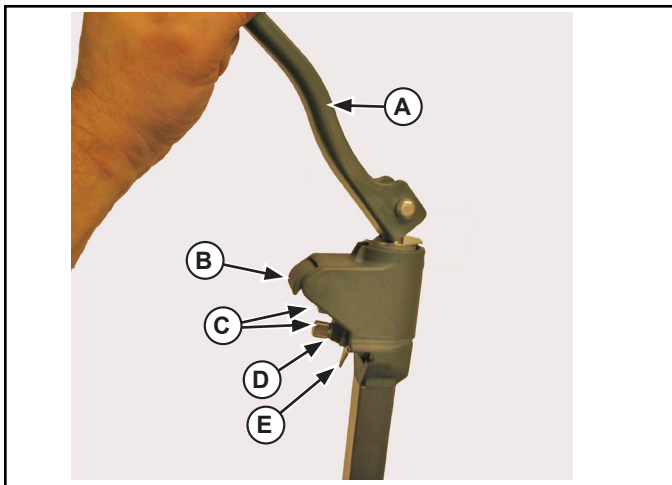

Figure 9. Blade Cartridge and Blade Removal and Installation.

2. Lift out the blade cartridge (B).
3. Note position or direction of the blade edge. Remove blade by loosening screws (C).
4. Discard the old blade (E) and replace with new blade. Inspect the O-rings (D) and replace if necessary.
5. Place the new blade (E) in the correct position. Secure with the screws (C) and O-rings (D).

To change the blade on Premium™ models:

1. Move the handle (A) to the position shown in Figure 10.
2. Note position or direction of the blade edge. Remove the blade by loosening screws (B).
3. Discard the old blade (C) and replace with new blade.
4. Place the new blade in the correct position. Secure with the screws (B).

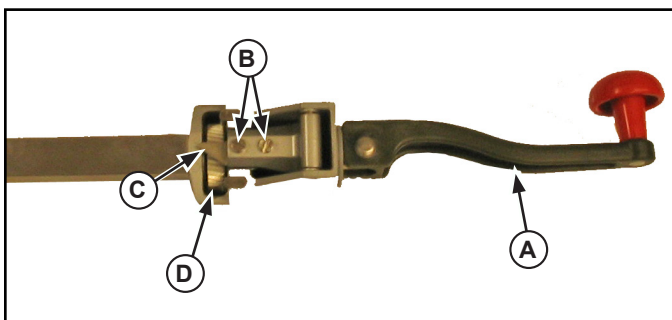

Figure 10. Blade and Gear Removal and Installation.

## REPLACING THE GEAR

Wash new parts with warm, soapy water and rinse thoroughly to remove the thin protective oil film.

To change the gear on EaziClean® models:

1. Use a tool to hold the old gear and turn the handle assembly in the counterclockwise direction to unscrew the gear.
2. Discard the old gear.
3. If the blade cartridge was removed during gear removal it will be necessary to align the collar (A) to the head (B). Rotate the grooves (C) so they align with ridges (D) and slide collar (A) into head (B). See Figure 11.

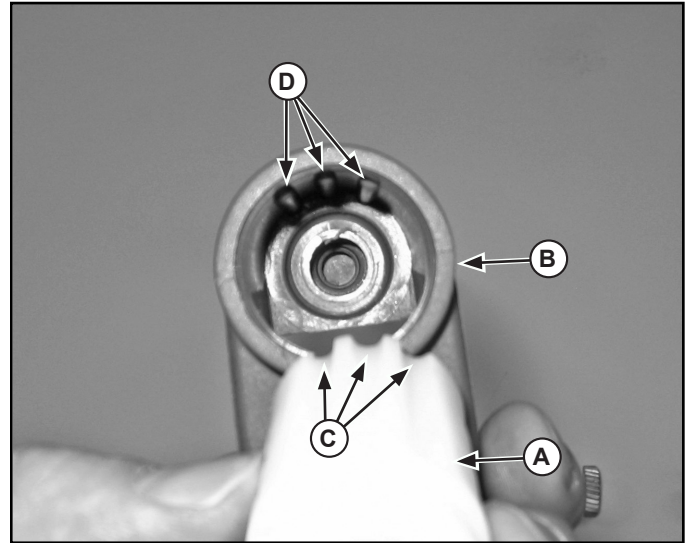

Figure 11. Safe Operation Switch.

4. Move the handle (A) to the "UP" position. See Figure 10.
5. Slide the gear into position.
6. Use a tool to assure that the gear is held firmly. Lower the handle to the "normal" position and rotate in the clockwise until tight.
7. Remove the tool.

To change the gear on Premium™ models:

1. Use a tool to hold the old gear and turn the handle assembly in the counterclockwise direction to unscrew the gear.
2. Discard the old gear.
3. Move the handle (A) to the "UP" position. See Figure 10.
4. Slide the gear into position.
5. Use a tool to assure that the gear is held firmly. Lower the handle to the "normal" position and rotate in the clockwise until tight
6. Remove the tool.



**SERVICE AND REPAIR**

Please contact the qualified professional repair service listed below.

**VOLLRATH Induction Repair Service • 1-800-825-6036 (USA) or www.vollrathco.com**

When contacting the Authorized Professional Service Center, please be ready with the model number, serial number, and proof of purchase showing the date the unit was purchased.

**SPARE PARTS LIST AND DIAGRAM - PREMIUM™**

Callout	Part Number	Description
1	116	Handle Assembly (for BCO-1)
2	125	Collar Washer (for BCO-1)
3	122	Collar (for BCO-1)
4	BCO-11	Blade (for BCO-1)
5	BCO-12	1" Gear (for BCO-1)
6	BCO-3	Base (for BCO-1)
7	N/A	Screws
8	N/A	Washers
9	N/A	Bar

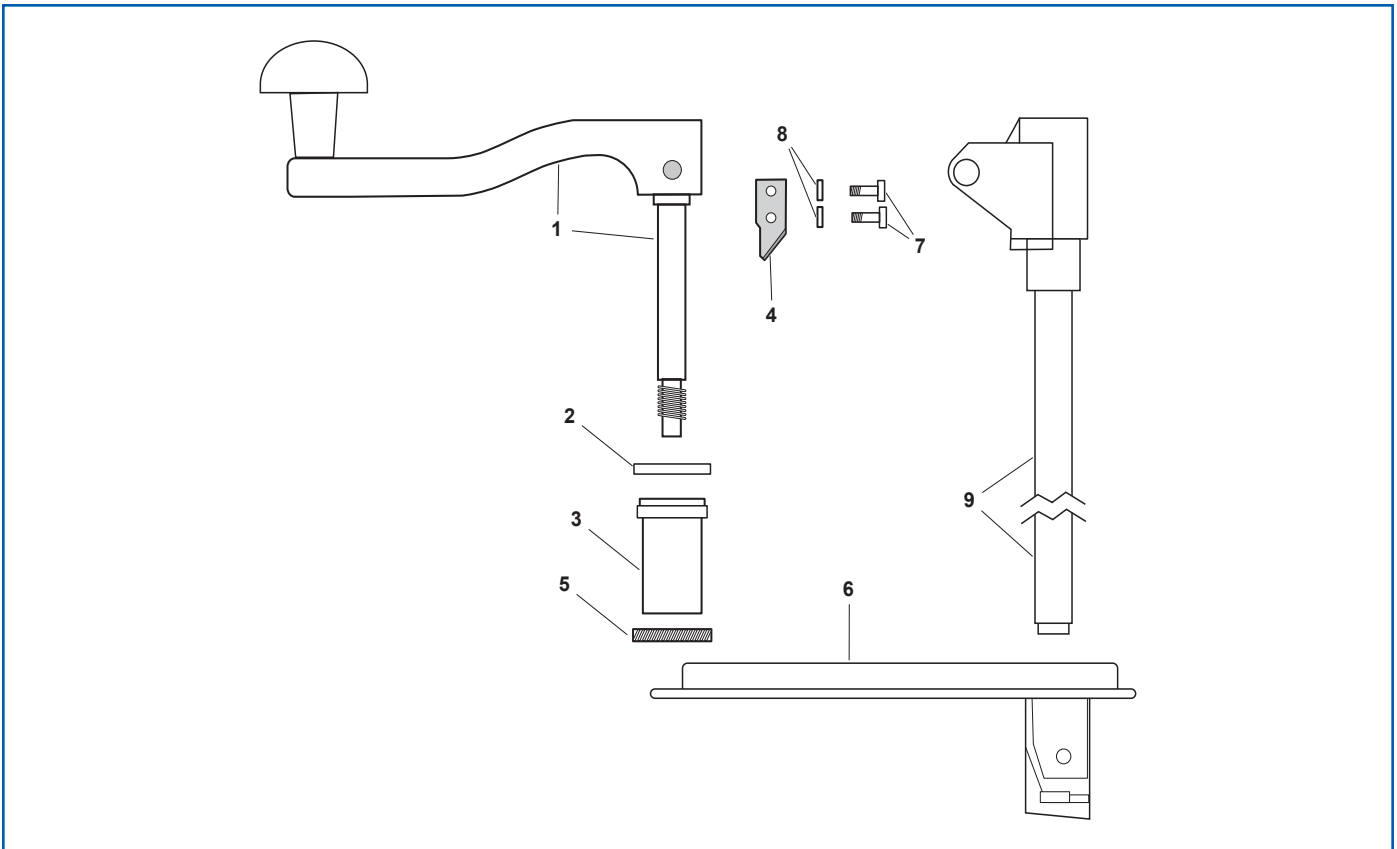

ENGLISH

**SPARE PARTS LIST AND DIAGRAM - EAZICLEAN<sup>®</sup>™**

Callout	Part Number	Description
1	379080	Handle Assembly (for BCO-2000 and BCO-3000)
1	379093	Handle Assembly (for BCO-5000 and BCO-6000)
1	379094	Handle Assembly (for BCO-7000)
2	122	Collar Washer (for BCO-2000 and BCO-3000)
2	379095	Collar Washer (for BCO-5000, BCO-6000, BCO-7000)
3	379082	Collar (for BCO-2000 and BCO-3000)
3	379096	Collar (for BCO-5000, BCO-6000, BCO-7000)
4	379083	Spring (for BCO-2000 and BCO-3000)
4	379097	Spring (for BCO-5000 and BCO-6000)
4	379098	Spring (BCO-7000)
5	BCO-12	1" Gear (for BCO-2000 and BCO-3000)
5	BCO-10	1-1/2" Gear (for BCO-5000, BCO-6000, BCO-7000)
6	BCO-15	Quick Release Replacement Cartridge (for BCO-2000 and BCO-3000)
6	BCO-14	Quick Release Replacement Cartridge (for BCO-5000, BCO-6000, BCO-7000)
7	BCO-16	Blade Screws and O-Ring Washers
8	BCO-11	Blade
9	BCO-3	Base
10	379090	Clamp
11	379089	Base and Clamp (Includes (Ref. Nos. 9 and 10)
12	379099	Bushing (for BCO-5000, BCO-6000, BCO-7000)
13	N/A	Bar

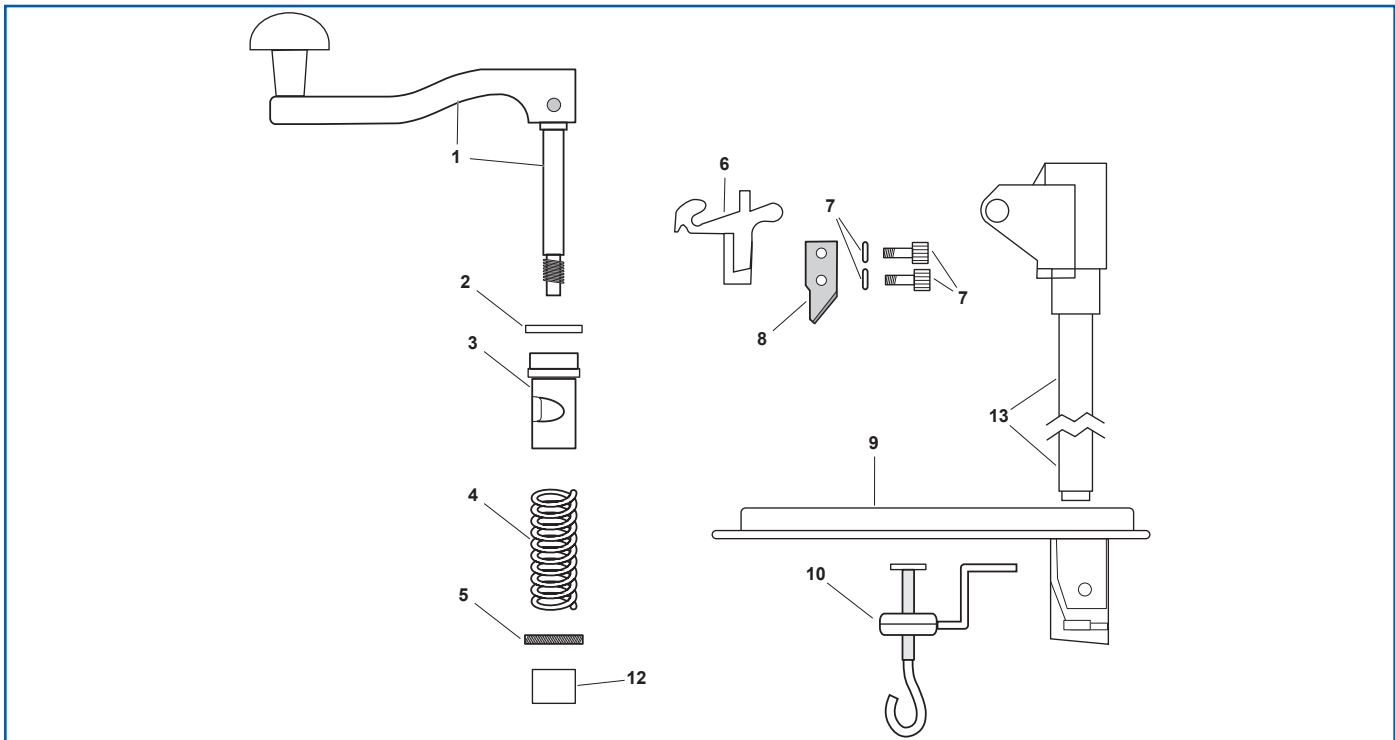

## WARRANTY STATEMENT FOR THE VOLLRATH CO. L.L.C.

The Vollrath Company LLC warrants the products it manufactures and distributes against defects in materials and workmanship for a period of one year, except as specifically provided below. The warranty runs 12 months from the date of original installation. (End user receipt)

1. Refrigeration compressors – The warranty period is 5 years.
2. Replacement parts – The warranty period is 90 days.
3. Fry pans and coated cookware – The warranty period is 90 days
4. EverTite™ Riveting System – The warranty covers loose rivets only, forever.
5. Cayenne® Heat Strips – The warranty period is 1 year plus an additional 1 year period on heating element parts only.
6. Ultra and Professional Induction Ranges – The warranty period is 2 years.
7. Mirage and Commercial Induction ranges - The warranty period is 1 year.
8. ServeWell® Induction Workstations – The warranty period is one year on the workstation table and 2 years on induction hobs.
9. Slicers – The warranty period is 10 years on gears and 5 years on belts.
10. Mixers – The warranty period is 2 years.
11. Extended warranties are available at the time of sale.
12. Boxer Mixers – 1 Year exchange Warranty.
13. Vollrath – Redco products – The warranty period is 2 years.
14. Optio / Arkadia product lines – The warranty period is 90 days.
15. All non-stick products (i.e. fry pans and surfaces) are 90 days for the non stick surfaces.

All products in the Jacob's Pride® collection, including the following, have a lifetime warranty:

- NSF Certified One-Piece Dishers
- NSF Certified Spoodle® Utensils
- NSF Certified Heavy-Duty Spoons with Ergonomic Handle
- NSF Certified Heavy-Duty Basting Spoons
- Heavy duty Turners with Ergonomic handle
- One-Piece Tongs\*
- Heavy-Duty One-Piece Ladles\*
- Nylon Handle Whips
- One-Piece Skimmers
- Tribute®, Intrigue®, and Classic Select® Cook-ware\*

\*Jacob's Pride® warranty does not cover Kool-Touch®, non stick coatings and silicone handles.

**Items sold having no warranty:**

- Meat Grinder Knives
- Light Bulbs in Convection Ovens and Hot Food Merchandiser
- Oven Door Seals
- Oven Door Glass
- Hot Food Merchandisers / Display Case Glass
- Calibration and set up of gas equipment
- Slicer / Dicer blades (table top food prep) – Redco and Vollrath
- Slicer / Dicer blades (table top food prep) – Redco and Vollrath

**THIS WARRANTY IS IN LIEU OF ANY OTHER WARRANTIES, EXPRESS OR IMPLIED, INCLUDING ANY IMPLIED WARRANTY OF MERCHANTABILITY OR FITNESS FOR A PARTICULAR PURPOSE**

As The Vollrath Company LLC's only responsibility and the purchaser's only remedy, for any breach of warranty, The Vollrath Company LLC will repair or, at its option, replace the defective product or part without charge, except as otherwise provided below:

- For refrigeration compressors and the second year of the warranty on Cayenne® Heat Strips and mixers, The Vollrath Company LLC will provide the repaired or replacement part only; and the buyer will be responsible for all labor charges incurred in performing the repair or replacement.
- To obtain warranty service, the buyer will be responsible to return to The Vollrath Company LLC any product (other than gas equipment that is permanently installed) weighing less than 110 lbs. or located outside of a 50-mile radius of a certified technician designated by The Vollrath Company LLC to perform warranty repairs. If a Vollrath Technician cannot be contacted check the website for service contact points. (Please refer to the Product Catalogue for weights and sizes of product)
- No remedy will be available for products that have been damaged by accident, carelessness, improper installation, lack of proper setup or supervision when required, neglect, improper use, installation or operation contrary to installation and operating instructions or other causes not arising out of defects in materials or workmanship. At the buyer's request, The Vollrath Company LLC will repair and or replace such products at a reasonable cost.
- No remedy will be available for slicers where blade has not been sharpened (Refer to owner's manual for sharpening instructions)
- No remedy will be available for mixers damaged by changing gears while unit is running or overloading, in either case as determined by a Vollrath Certified Technician
- Warranty work must be authorized in advance by The Vollrath Company LLC. See the operating and safety instructions for each product for detailed warranty claim procedures.
- No remedy will be available for product returned and found to be acceptable to the product specification.
- No remedy will be available under any warranty not registered as required below.

**LIMITATION OF LIABILITY:**

**THE VOLLRATH COMPANY LLC SHALL HAVE NO LIABILITY FOR INCIDENTAL OR CONSEQUENTIAL DAMAGES OF ANY KIND, WHETHER BASED UPON NEGLIGENCE OR OTHER TORT, BREACH OF WARRANTY, OR ANY OTHER THEORY.**

ENGLISH



## WARRANTY PROCEDURE

On all warranty calls, the following process and information is required:

- All warranty claims will start with a call to Vollrath Technical Service support line. (800-628-0832).
- A technical support professional will work to diagnose the issues, and provide the details for the service solution.
- Name and phone number of person calling
- Business name, street address, city, state and zip
- Model and serial number
- Date of purchase and proof of purchase (Receipt)
- Name of dealer where unit was purchased

NOTE: Vollrath will not accept products sent without the proper procedure being followed.

### Important:

TO MAKE A CLAIM FOR ANY REMEDY UNDER THIS WARRANTY, YOU MUST REGISTER YOUR WARRANTY.

## REGISTER TODAY

ONLINE: Register your warranty on-line now at [www.Vollrathco.com](http://www.Vollrathco.com)

NO WEB ACCESS: If you do not have access to the web, kindly register by completing the warranty registration form and faxing it to The Vollrath Co. LLC office in the country of purchase.

WARRANTY REGISTRATION			
BUSINESS NAME			
KEY CONTACT NAME		EMAIL	
STREET ADDRESS			
CITY		STATE	ZIP CODE
COUNTRY	PHONE	FAX	
MODEL		ITEM NUMBER	
SERIAL NUMBER			
OPERATION TYPE			
<input type="checkbox"/> Limited Service Restaurant	<input type="checkbox"/> Full Service Restaurant	<input type="checkbox"/> Bars and Taverns	<input type="checkbox"/> Supermarket
<input type="checkbox"/> Convenience Store	<input type="checkbox"/> Recreation	<input type="checkbox"/> Hotel/Lodging	<input type="checkbox"/> Airlines
<input type="checkbox"/> Business/Industry	<input type="checkbox"/> Primary/Secondary School	<input type="checkbox"/> Colleges/University	<input type="checkbox"/> Hospitals
<input type="checkbox"/> Long-Term Care	<input type="checkbox"/> Senior Living	<input type="checkbox"/> Military	<input type="checkbox"/> Corrections
REASON FOR SELECTING OUR PRODUCT			
<input type="checkbox"/> Appearance	<input type="checkbox"/> Full Service Restaurant	<input type="checkbox"/> Availability	<input type="checkbox"/> Sellers Recommendation
<input type="checkbox"/> Ease of Operation	<input type="checkbox"/> Versatility of Use	<input type="checkbox"/> Price	<input type="checkbox"/> Brand
WOULD YOU LIKE TO RECEIVE OUR FULL-LINE CATALOG AND REMAIN ON OUR MAILING LIST?			<input type="checkbox"/> Yes <input type="checkbox"/> No



[www.vollrathco.com](http://www.vollrathco.com)

The Vollrath Company, L.L.C.  
1236 North 18th Street  
Sheboygan, WI 53081-3201  
U.S.A.

Main Tel: 800.628.0830  
Fax: 800.752.5620

Technical Services: 800.628.0832  
Service Fax: 920.459.5462

Canada Service: 800.695.8560

© 2010 The Vollrath Company, L.L.C.