

# robot coupe®



**R 100**



**R 101**



**R 101B**



**R 101 Plus**

**Robot-coupe USA, Inc.**

P.O. Box 16625, Jackson, MS 39236-6625 - 264 South Perkins St., Ridgeland, MS 39157  
e-mail: [info@robotcoupeusa.com](mailto:info@robotcoupeusa.com) - website: [www.robotcoupeusa.com](http://www.robotcoupeusa.com) - Phone : 1-800-824-1646

# SUMMARY

## ■ WARRANTY

## ■ IMPORTANT WARNING

## ■ INTRODUCTION TO YOUR NEW R 100 • R 101 • R 101 B • R 101 Plus

## ■ SWITCHING ON THE MACHINE

- Advice on electrical connections
- Control panel

## ■ ASSEMBLY

- Bowl attachment
- Vegetable preparation attachment

## ■ OPERATING INSTRUCTIONS

- Using the cutting blade
- Using the cutting plates

## ■ ACCESSORIES

## ■ CLEANING

- Attachments
- Motor base
- Blade and cutting plates

## ■ MAINTENANCE

- Blade and cutting plates
- Motor seal

## ■ SAFETY

## ■ TECHNICAL DATA

- Exploded views
- Electrical and wiring diagrams

# ROBOT COUPE U.S.A., INC. LIMITED WARRANTY

**YOUR NEW ROBOT COUPE PRODUCT IS WARRANTED TO THE ORIGINAL PURCHASER FOR A PERIOD OF ONE YEAR FROM THE DATE OF PURCHASE.**

**This LIMITED WARRANTY is against defects in the material and/or workmanship, and includes labor for replacement of defective parts, provided repairs are performed by an authorized service agency (see attached list).**

**The Customer must inform the Service Agency of the possibility of warranty coverage and provide a copy of the dated sales or delivery receipt BEFORE WARRANTY REPAIRS ARE BEGUN.**

**Replacement parts and accessories are warranted for ninety (90) days from the date of purchase when purchased separately and will be verified by dated sales receipt OR packing slip which lists that item.**

**All parts or accessories replaced under warranty must be returned to the Service Agency.**

## **THE FOLLOWING ARE NOT COVERED BY THE ROBOT COUPE U.S.A. INC LIMITED WARRANTY:**

- 1** - Damage caused by abuse, misuse, dropping, or other similar damage caused by or resulting from failure to follow assembly, operating, cleaning, user maintenance or storage instructions.
- 2** - Labor to sharpen and/or replacements for blades that have become blunt, chipped or worn after a normal or excessive period of use.
- 3** - Materials or labor to replace or repair scratched, stained, chipped, pitted, dented or discolored surfaces, blades, knives, attachments or accessories.
- 4** - Any alteration, addition, or repair that has not been carried out by the company or an approved service agency.
- 5** - Transportation of the appliance to or from an approved service agency.
- 6** - Labor charges to install or test new attachments or accessories (i.e., bowls, plates, blades, attachments), which have been replaced for any reason.

**7** - The cost of changing direction-of-rotation of three-phase electric motors (Installer is responsible).

**8** - SHIPPING DAMAGES. Visible and/or hidden damage is the responsibility of the freight carrier. The consignee must inform the carrier and consignor immediately, or upon discovery in the case of hidden defects.

**KEEP ALL ORIGINAL CONTAINERS AND PACKING MATERIALS FOR CARRIER INSPECTION.**

Neither ROBOT COUPE U.S.A., INC. nor its affiliated companies or any of its distributors, directors, agents, employees, or insurers will be liable for indirect damage, losses, or expenses linked to the appliance or the inability to use it. **The ROBOT COUPE U.S.A., INC. warranty is given expressly and in lieu of all other warranties, expressed or implied, for merchantability and for fitness toward a particular purpose and constitutes the only warranty made by ROBOT COUPE U.S.A., INC..**

# IMPORTANT WARNING



**WARNING:** In order to limit accidents such as electric shocks, personal injury or fire, and in order to limit material damage due to misuse of the appliance, please read these instructions carefully and follow them strictly. Reading the operating instructions will help you get to know your appliance and enable you to use the equipment correctly. The operation manual should be kept within easy access to all users for reference and should be read completely by all first time users of the machine.

## UNPACKING

- Carefully remove the equipment from the packaging and take out all the boxes or packets containing attachments or specific items.
- **WARNING**-some of the parts are very sharp e. g. blades, plates ... etc.

## INSTALLATION

- We recommend that you install your machine on a stable solid base at a comfortable working height.

## CONNECTION

- Always check that your power supply corresponds to that indicated on the serial number plate and that it is properly sized.

## HANDLING

- Always wear cut-resistant gloves when handling the cutting plates or the cutter blade.

## ASSEMBLY PROCEDURES

- Follow the various assembly procedures carefully (see page 6) and make sure that all the attachments are correctly positioned.

## USE

- Do not open the feed lead / attachment until the motor has come to a complete stop.
- Never tamper with, or defeat the purpose of the locking and safety systems.
- Do not put nonfood objects in the bowl or vegetable prep openings.
- Always use the food pushers to push the product into the vegetable preparation attachment openings.
- Do not leave the machine running unattended.

## CLEANING

- Always unplug your machine before cleaning.
- Always clean the machine and attachments at the end of each use.
- Never place the motor unit in water.

- For parts made of aluminum alloys, use cleaning detergents suitable for aluminum.
- For plastic parts, do not use detergents that are too alkaline (i.e., containing too much caustic soda or ammonia...).

Robot Coupe can in no way be held responsible for the user's failure to follow the basic rules of cleaning and maintenance.

## MAINTENANCE

- Always unplug the appliance before servicing.
- Check the seals regularly and ensure that the safety devices are in good working order.
- It is particularly important to maintain and check the attachments since certain products contain corrosive agents e.g. citric acid.
- **NOTICE:** Never operate the appliance if the power cord or plug has been damaged.
- If the machine fails to operate as described in this manual, or if the machine malfunctions in any way, remove the machine from use and have it serviced. Additionally, discard all food processed at the time of the malfunction.
- Contact your local Authorized Service Agency if something appears to be wrong.

## INTRODUCTION TO YOUR NEW R 100 • R 101 • R 101 B • R 101 Plus

The R 100, R 101, R 101B and R 101 Plus is a versatile machine designed to meet your professional needs. It can perform a number of tasks, as well as save much in time and labor.

This food processor consists of a bowl assembly and a vegetable preparation lid that ejects into the bowl. The 2.5 quart bowl is used for chopping, grinding, pureeing, blending, mixing, and kneading of ingredients required in most every recipe.

A wide range of cutting plates is available for use with the vegetable preparation attachment. Cutting plates are available for slicing, waved slicing, grating, pulping, and julienne.

Its numerous functions will open the door to a whole new culinary world.

Thanks to its simple design, all components requiring frequent handling for maintenance or cleaning can be easily assembled and removed.

All users should read this operation manual before operating the machine.

## SWITCHING ON THE MACHINE

### • ADVICE ON ELECTRICAL CONNECTIONS

Before plugging in, check that your power supply corresponds to that indicated on the machine's serial number plate.



## WARNING

This appliance must be plugged into an grounded socket (risk of electrocution).

### • CONTROL PANEL



#### R 100 / R 101

Red switch= Off switch  
Green switch = On switch

#### R 101 B / R 101 Plus

Red switch = Off switch  
Green switch = On switch  
Black switch = Pulse switch

R 101 Plus also available with a grey bowl.



## ASSEMBLY

### • BOWL ATTACHMENT

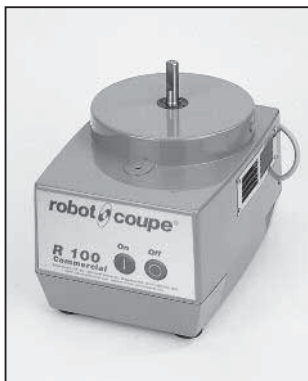

1) With the motor base facing you, place the bowl onto the motor base with the pin toward the front. Turn the bowl just off-center and to the left as you lower it onto the base.

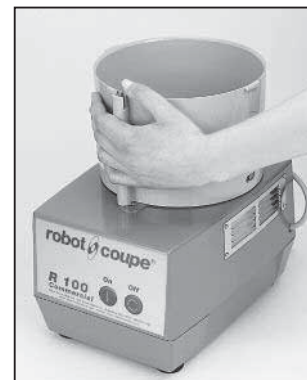

2) Then, turn the bowl back to the right. The safety switch pin should come to a stop at the front of the motor base. The bowl, when properly assembled, should be just off and level with the top surface of the motor base assembly.

3) Place the blade onto the motor shaft. Rotate the blade until it drops into place. The bottom blade should be level with, and just off the bottom of the bowl.

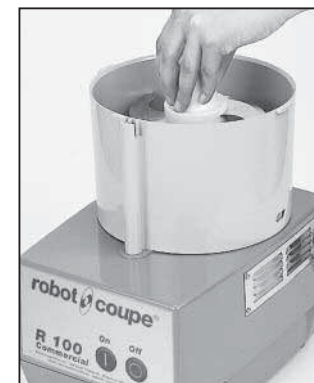

4) **Press the off button in case the machine was left turned on.** Place the lid on the bowl so that the large feed-hopper is facing you. Rotate to the right until it locks. The machine is now assembled and ready for use.

### • VEGETABLE PREPARATION ATTACHMENT

Follow the same procedure as for the cutter attachment for points 1) and 2).





3) With the metal pin side up, place the plate support on the motor shaft. Rotate the plate support until it falls into place on the motor shaft.

4) Put the cutting plate of your choice on the motor shaft. Rotate the plate until it falls into place on the plate support.

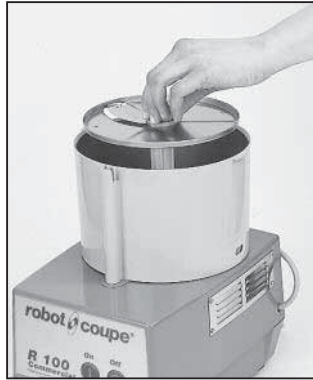

5) Press the off button in case the machine was left turned on. Place the lid on the bowl so that the large feed-hopper is facing you. Close the lid by rotating to the right until it locks.



### REMEMBER:

R 101 B is delivered as a bowl cutter mixer only (no vegetable preparation attachment)



## OPERATING INSTRUCTIONS

### THE UNIT SHOULD BE OFF EXCEPT WHEN PROCESSING IS UNDERWAY.

It is recommended that the machine be operated on a 50% duty cycle. This is easily accomplished since the preparation time (cleaning, coring, peeling, and loading) takes longer than the processing time. This will yield the longest life for your machine.

#### • USING THE CUTTING BLADE

The blade is used for grinding, kneading, pureeing, blending, mixing, and emulsifying. Before placing the product in the bowl some products such as meats and cheeses should be pre-cut into 1-2 inch portions. When filling the bowl, allow space above the product for circulation.

There are two ways to run your machine: Chopping, using a pulse or start/stop action with the on/off switches (use the pulse button on the R 101 B and R 101 Plus), or running continuously for a fine chop or puree. To obtain a uniform chop of products such as meats and cheeses, begin with a uniformly portioned product. Pulse the machine until the desired result is reached. Then, if a puree or fine chop is desired, press the on button, and allow the machine to run until the product is the right consistency.

USES	Max. processing quantity (in pounds)	Processing time (in mn)
<b>CHOP</b>		
<b>• MEAT</b>		
Hamburgers/steak tartare	1 ¾	3
Sausage/meat/tomatoes	1 ½	3
Terrine/pâté	1 ½	4

<b>• FISH</b>		
Brandade	2 ¼	5
Terrines	2 ¼	5
<b>• VEGETABLES</b>		
Garlic/parsley/onion/shallots	½ / 1	3
Soup / purées	2 ¼	4
<b>• FRUIT</b>		
Compotes / purées	2 ¼	4
<b>EMULSIFY</b>		
Mayonnaise / aïoli / remoulade sauce	2 ¼	3
Snail or salmon butter	1 ¼	4
<b>KNEAD</b>		
Shortcrust pastry/shortbread	2	4
Pizza dough	2	4
<b>GRIND</b>		
Dried fruit	1	4
Parsley	1	4
Breadcrumbs	1	5

The cutter version has numerous other applications. The above quantities and times are approximate and may vary according to the quality of the ingredients and recipes.

#### • USING THE CUTTING PLATES

The vegetable preparation attachment is used for slicing, grating, waved slicing, julienne, and pulping.

The vegetable preparation attachment consists of two feed openings :

- one large feed opening for cutting vegetables such as cabbage, celeriac, etc.
- a small feed opening for long vegetables and high-precision cutting.





Do not attempt to run frozen products through the cutting plates.

Do not put anything other than food products into the feed openings.

Do not remove attachments while the motor is running.

Do not apply excess pressure to the food pushers: This can cause damage to the motor and other parts.

Remove the pusher, and fill the selected opening with the product. Hold the pusher over the opening, and press the on button. Apply steady but moderate pressure to the pusher until the pusher has come to a stop.

SLICERS 			
3/64	carrot / cabbage / cucumber / onion / potato / leek		
5/64 - 1/8	lemon / carrot / mushroom / cabbage / potato / cucumber / zucchini / onion / leek / bell pepper		
5/32 - 3/16	eggplant / beet root / carrot / mushroom / cucumber / bell pepper / radish / lettuce / potato / leek / tomato		
1/4	eggplant / beet root / carrot / mushroom / cucumber / bell pepper / radish / lettuce / potato / leek		
RIPPLE CUT SLICER 			
5/64	beet root / potato / carrot		
GRATERS 			
1/16	celeriac / cheese	3/8	cabbage / cheese
5/64	carrot / celeriac / cheese	Hard cheese	
1/8	carrot	1/32	Extra fine
1/4	cabbage / cheese	3/64	Pulping
JULIENNE 			
5/64 x 5/64	carrot / celeriac / potato		
5/64 x 5/32	carrot / beet root / zucchini / potato		
5/64 x 1/4	carrot / beet root / zucchini / potato		
5/32 x 5/32	eggplant / beet root / zucchini / potato		
1/4 x 1/4	eggplant / beet root / celeriac / zucchini / potato		
5/16 x 5/16	celeriac / potato		

## ACCESSORIES



A coarse serrated blade is available as an option and is mainly intended for kneading and grinding.

A fine serrated blade is available mainly for use in chopping parsley. The blade edge is longer lasting than the smooth blade but cannot be sharpened.



We advise you to use this blade mainly to chop parsley.

## CLEANING

 **WARNING**

**As a precaution, always unplug your appliance before cleaning it (risk of electric shock).**

### • ATTACHMENTS

Remove all attachments before cleaning. The bowl and lid attachments should be cleaned per the following instructions or as required by local health department regulations.

**CLEAR PLASTIC BOWLS:** Some models, such as the R 101 Plus, are shipped with a clear plastic bowl. **NEVER CLEAN CLEAR PLASTIC BOWLS WITH CLORINE.**

The bowl, blade, lid, pushers, and plates are dishwasher safe. All of the attachments listed above can be washed in a dish machine or three-tank system pot sink. Pre-rinse the attachments before washing to remove any bulk food on the parts. A stiff bristle brush or power sprayer faucet attachment is effective in knocking the food out of the crevices as a pre-rinse procedure. The washer should have an industry standard wash, rinse and sanitization cycle. Allow the parts to air dry after sanitizing and before reassembly.

**NOTE: The high temperatures of dish machines will tend to shorten the life of the plastic and rubber parts. Hand washing using a three-pot sink will provide for the longest life of these parts. Wear cut-resistant gloves when cleaning the blade and plates.**

Clean the outside of the bowl, the lid, and around the switch pin to ensure they are clean. Use a brush on these areas if necessary.

### • MOTOR BASE

Cleaning of the motor base assembly must be done with care. The motor base contains the electrical components.

**NEVER IMMERSE THE MOTOR BASE ASSEMBLY IN WATER.**

**First, unplug the power cord.** Wipe down the motor base using a cloth lightly dampened (not dripping) with water, then with a sanitizing solution, and dry the machine with a soft cloth removing all liquids from the seal area. Do not allow water to penetrate the shaft seal or around the switches. Clean around the shaft seal with a small brush, taking care to remove all food. Do not forget to clean the motor shaft.

## • BLADE AND CUTTING PLATES

Handle the blades and cutting plates with caution to prevent cuts. A stiff, long handled, bristle brush can be a very effective tool for cleaning the blade and cutting plates.



## I M P O R T A N T

Check that your detergent is suitable for cleaning plastic parts. Some washing agents are too alkaline (e.g. high levels of caustic soda or ammonia) and totally incompatible with certain types of plastic, causing them to deteriorate rapidly.

## MAINTENANCE

### • BLADE AND CUTTING PLATES

Blades should be kept sharp. It is not necessary to have a razor edge. However, they will need sharpening periodically. Replacement of the dull blades or plates is recommended.

### • MOTOR SEAL

An examination should be made periodically to assure that a seal against liquids is being maintained around the motor shaft. With proper care, and depending on use, the seal should last for a year or more. However, it can and should be replaced whenever wear or erosion is noted, or minimally once every three to six months. It is recommended that the seal be replaced by an authorized repair agency.

## SAFETY

To avoid splashing when running liquids in the bowl, allow the blades to completely stop before opening the lid.



## W A R N I N G

**The blades are extremely sharp. Handle with care.**

The R 100, R 101, R 101B and R 101 Plus are fitted with a mechanical safety switch that causes the machine to turn off when the lid is removed. If this safety feature should ever fail, remove the machine from use and have the machine repaired by your service agency.

**NOTE :** The machines are equipped with a **thermal protector** which automatically stops the motor if the machine is left on for too long or overloaded. If this happens, allow the machine to cool completely before restarting.



## R E M E M B E R

**Never try to override or defeat the purpose of the locking and safety systems.**

**Never put nonfood objects into the machine openings.**

**Only use the food pushers to push the food into the machine.**

**Do not overload the appliance.**

**Never leave the machine running unattended.**





# R 100 Commercial

Serial number 251xxxxx03

Serial number 640xxxxx03

1 Speed, 120 Volt, 1 Phase  
60Hz, 1/2 HP, 1800 RPM, 7 Amps

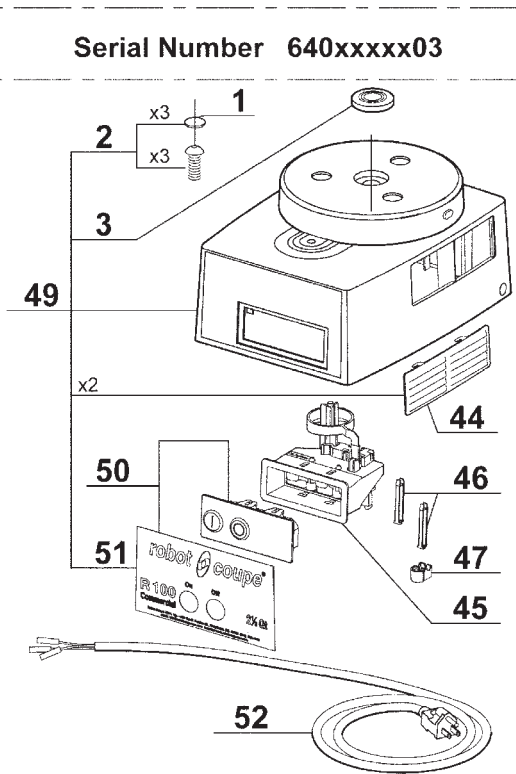
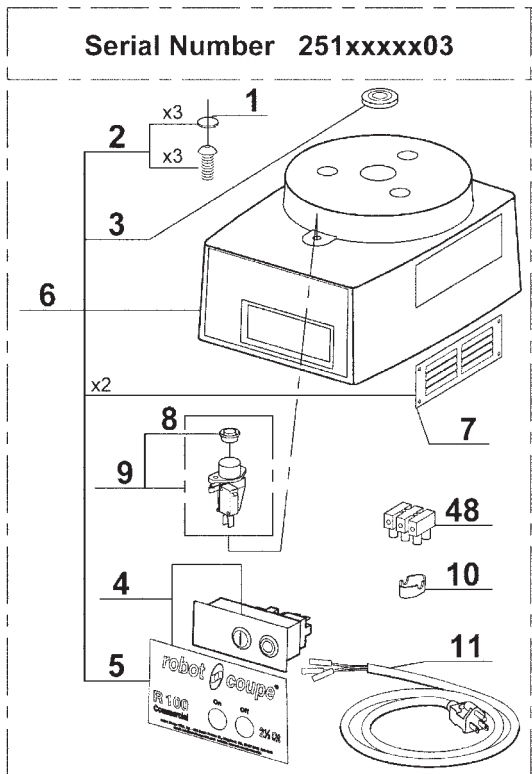
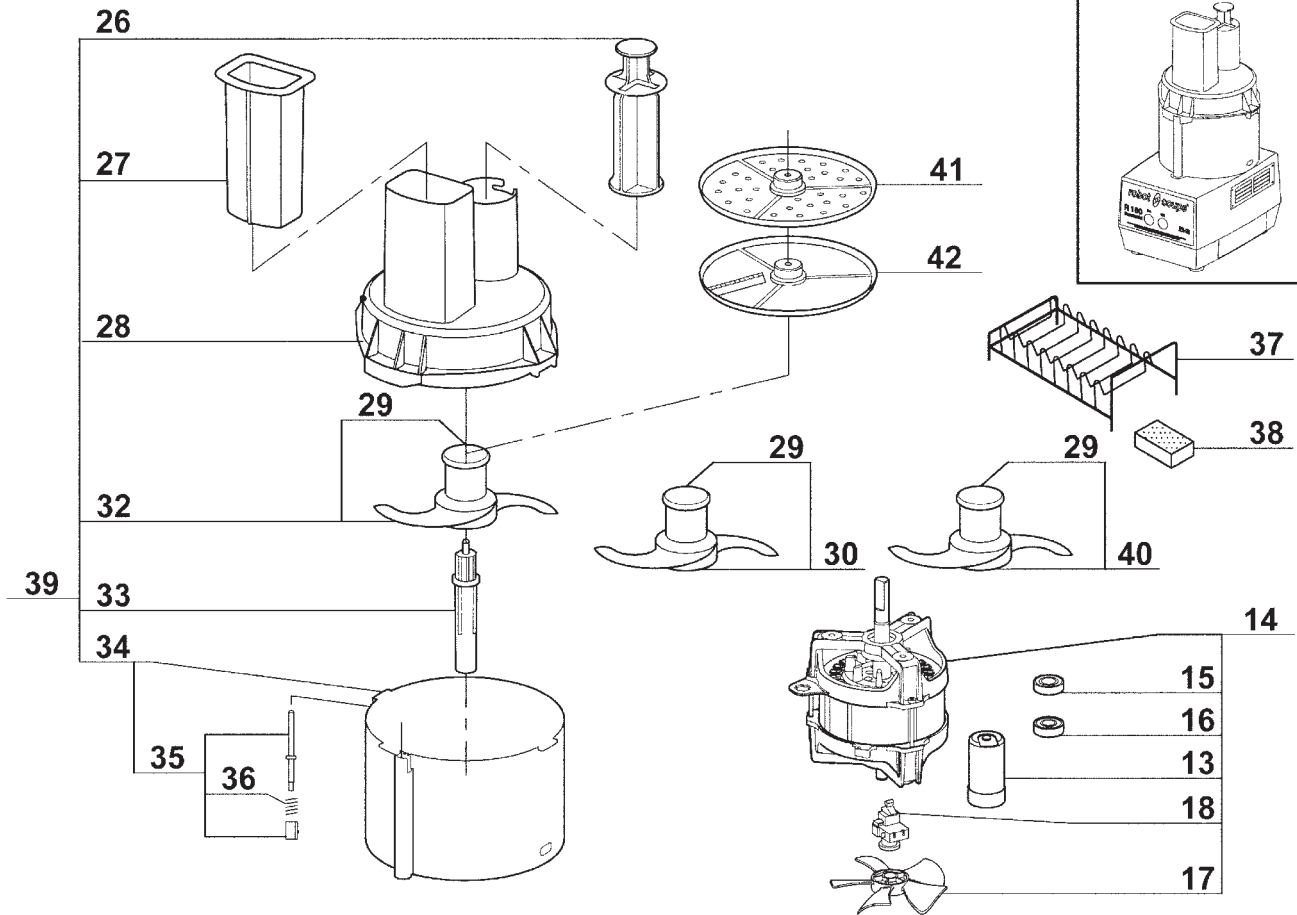
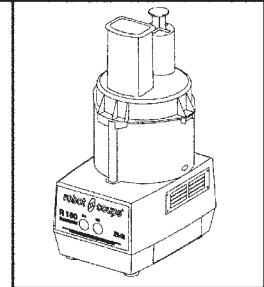

ETL LISTED 54881  
Conforms to  
UL NSF/ANSI  
Std 763 Std 8  
Certified to  
CAN/CSA  
Std C22.2 No.195



PH: 1-800-824-1646 FAX: 601-898-9134  
email: info@robotcoupeusa.com

Index	Pièce / Part	Description
1	102 709	BOLT COVER
2	29 633	SCREW ASSEMBLY
3	501 010	MOTOR SEAL
4	29 208	COMPLETE ON / OFF SWITCH ASSEMBLY
5	400 541	FRONT PLATE
6	29 567	MOTOR SUPPORT ASSEMBLY
7	101 098	VENTILATION GRID
8	500 527	RUBBER O RING
9	29 918	MICROSWITCH ASSEMBLY
10	101 106	POWER CORD CLIP
11	503 206	POWER CORD
13	603 669	STARTING CAPACITOR
14	3 215	MOTOR
15	504 229	UPPER BALL-BEARING 6002 2RS
16	600 457	LOWER BALL-BEARING 6201 2RS
17	117 610	MOTOR FAN
18	500 296	STARTING RELAY
19	101 097	VENTILATION BAFFLE
20	101 099	ABSORBER
22	102 697	BASE
24	39 928	FOOT (x4)
26	119 162	ROUND PUSHER
27	101 089	VEGETABLE PUSHER
28	101 088	LID
29	117 058	BLADE CAP
30	27 062	FINE SERRATED BLADE
32	27 054	SMOOTH BLADE
33	101 090	DISC STEM
34	102 702	GREY BOWL
35	29 007	COMPLETE SAFETY ROD
36	100 964	SPRING
37	R 255	PLATE RACK
38	502 579	HONING STONE
39	27 402	CUTTER ATTACHMENT
40	27 161	SERRATED BLADE
41	27 577	GRATER 2 mm
42	27 566	SLICER 4 mm
43	103 761	VENTILATION SCREEN
44	104 122	VENTILATION GRID
45	39 877	SAFETY ASSEMBLY
46	39 876	PANEL KEY ASSEMBLY
47	49 000	POWER CORD CLIP
48	19 188	TERMINAL BLOCK
49	49 011	MOTOR SUPPORT ASSEMBLY
50	49 012	COMPLETE ON / OFF SWITCH ASSEMBLY
51	49 013	FRONT PLATE
52	39 890	POWER CORD

**robotcoupe**® U.S.A., Inc.

**R 101**  
Serial number 635xxxxx03

1 Speed, 120 Volt, 1 Phase  
60Hz, 1/2 HP, 1800 RPM, 7 Amps

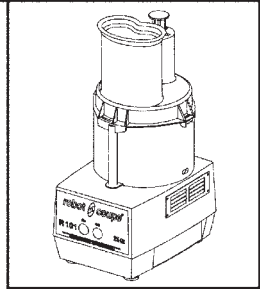
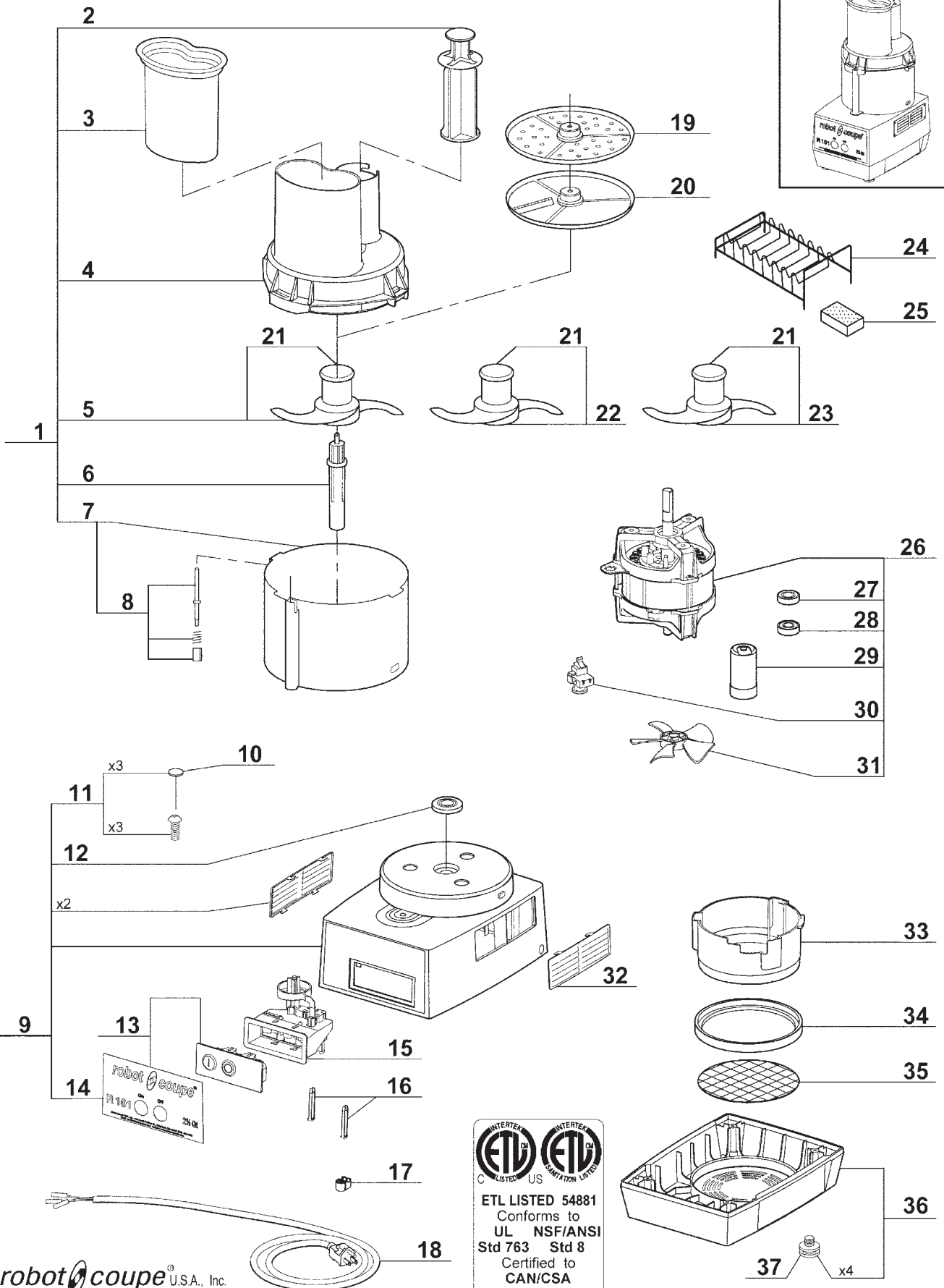

ETL LISTED 54881  
Conforms to  
UL NSF/ANSI  
Std 763 Std 8  
Certified to  
CAN/CSA  
Std C22.2 No.195

**robotcoupe**® U.S.A., Inc.

PH: 1-800-824-1646 FAX: 601-898-9134  
email: info@robotcoupeusa.com

Index	Pièce / Part	Description
1	27 398	CUTTER ATTACHMENT
2	119 162	ROUND PUSHER
3	112 216	VEGETABLE PUSHER
4	112 206	LID
5	27 054	SMOOTH BLADE
6	101 090	DISC STEM
7	102 702	BOWL
8	29 007	COMPLETE SAFETY ROD
9	49 011	MOTOR SUPPORT ASSEMBLY
10	102 709	BOLT COVER
11	29 633	SCREW ASSEMBLY
12	501 010	MOTOR SEAL
13	49 012	COMPLETE ON / OFF / PULSE SWITCH ASSEMBLY
14	49 013	FRONT PLATE
15	39 877	SAFETY ASSEMBLY
16	39 876	PANEL KEY ASSEMBLY
17	49 000	POWER CORD CLIP
18	39 890	POWER CORD
19	27 577	GRATER 2 mm
20	27 566	SLICER 4 mm
21	117 058	BLADE CAP
22	27 161	SERRATED BLADE
23	27 062	FINE SERRATED BLADE
24	R255	PLATE RACK
25	R248	SHARPENING STONE
26	3 216	MOTOR
27	504 229	UPPER BALL-BEARING 6002 2RS
28	600 457	LOWER BALL-BEARING 6201 2RS
29	603 669	STARTING CAPACITOR
30	500 296	STARTING RELAY
31	117 610	MOTOR FAN
32	104 122	VENTILATION GRID
33	101 097	VENTILATION BAFFLE
34	101 099	ABSORBER
35	103 761	VENTILATION SCREEN
36	102 697	BASE
37	39 928	FOOT (x4)

**robotcoupe**® U.S.A., Inc.

**R 101 B**  
Serial number 639xxxxx03

1 Speed, 120 Volt, 1 Phase  
60Hz, 1/2 HP, 1800 RPM, 7 Amps

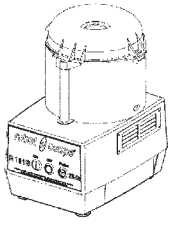
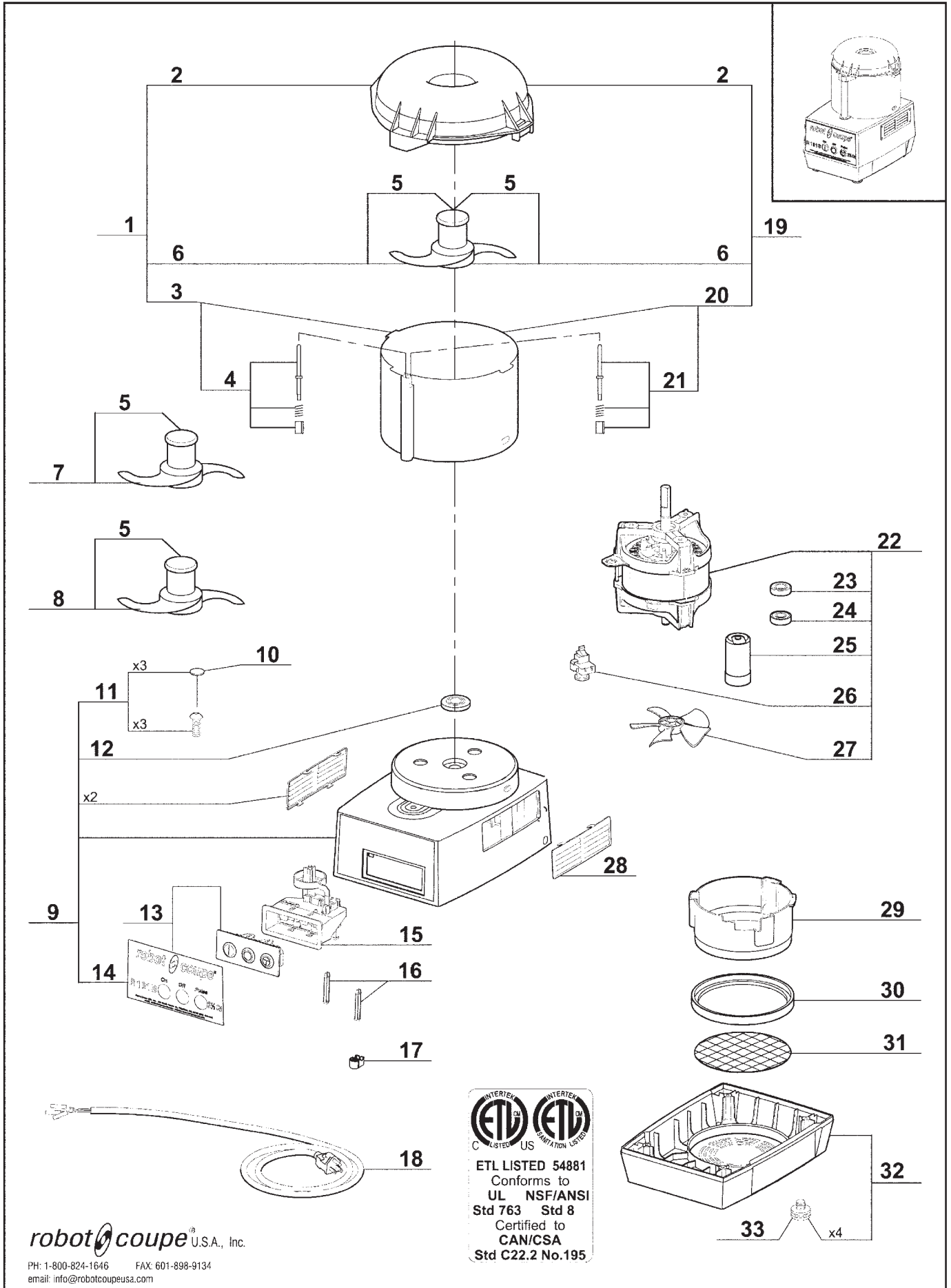

ETL LISTED 54881  
Conforms to  
UL NSF/ANSI  
Std 763 Std 8  
Certified to  
CAN/CSA  
Std C22.2 No.195

**robotcoupe**® U.S.A., Inc.  
PH: 1-800-824-1646 FAX: 601-898-9134  
email: info@robotcoupeusa.com



Index	Pièce / Part	Description
1	27 224	GREY CUTTER ATTACHMENT
2	106 458	CUTTER LID
3	102 702	GREY BOWL ASSEMBLY
4	29 007	COMPLETE SAFETY ROD
5	117 058	BLADE CAP
6	27 054	SMOOTH BLADE
7	27 062	FINE SERRATED BLADE
8	27 161	SERRATED BLADE
9	49 014	MOTOR SUPPORT ASSEMBLY
10	102 709	BOLT COVER
11	29 633	SCREW ASSEMBLY
12	501 010	MOTOR SEAL
13	49 015	COMPLETE ON / OFF / PULSE SWITCH ASSEMBLY
14	49 017	FRONT PLATE
15	39 877	SAFETY ASSEMBLY
16	39 876	PANEL KEY ASSEMBLY
17	49 000	POWER CORD CLIP
18	39 890	POWER CORD
19	27 231	CRISTAL CUTTER ATTACHMENT
20	117 900	CLEAR BOWL ASSEMBLY
21	29 900	PIN ASSEMBLY
22	3 216	MOTOR
23	504 229	UPPER BALL-BEARING 6002 2RS
24	600 457	LOWER BALL-BEARING 6201 2RS
25	603 669	STARTING CAPACITOR
26	500 296	STARTING RELAY
27	117 610	MOTOR FAN
28	104 122	VENTILATION GRID
29	101 097	VENTILATION BAFFLE
30	101 099	ABSORBER
31	103 761	VENTILATION SCREEN
32	102 697	BASE ASSEMBLY
33	39 928	FOOT (x4)

**robotcoupe**® U.S.A., Inc.

**R 101 Plus CB**  
Serial number 636xxxxx03

1 Speed, 120 Volt, 1 Phase  
60Hz, 1/2 HP, 1800 RPM, 7 Amps

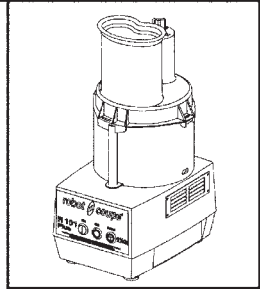
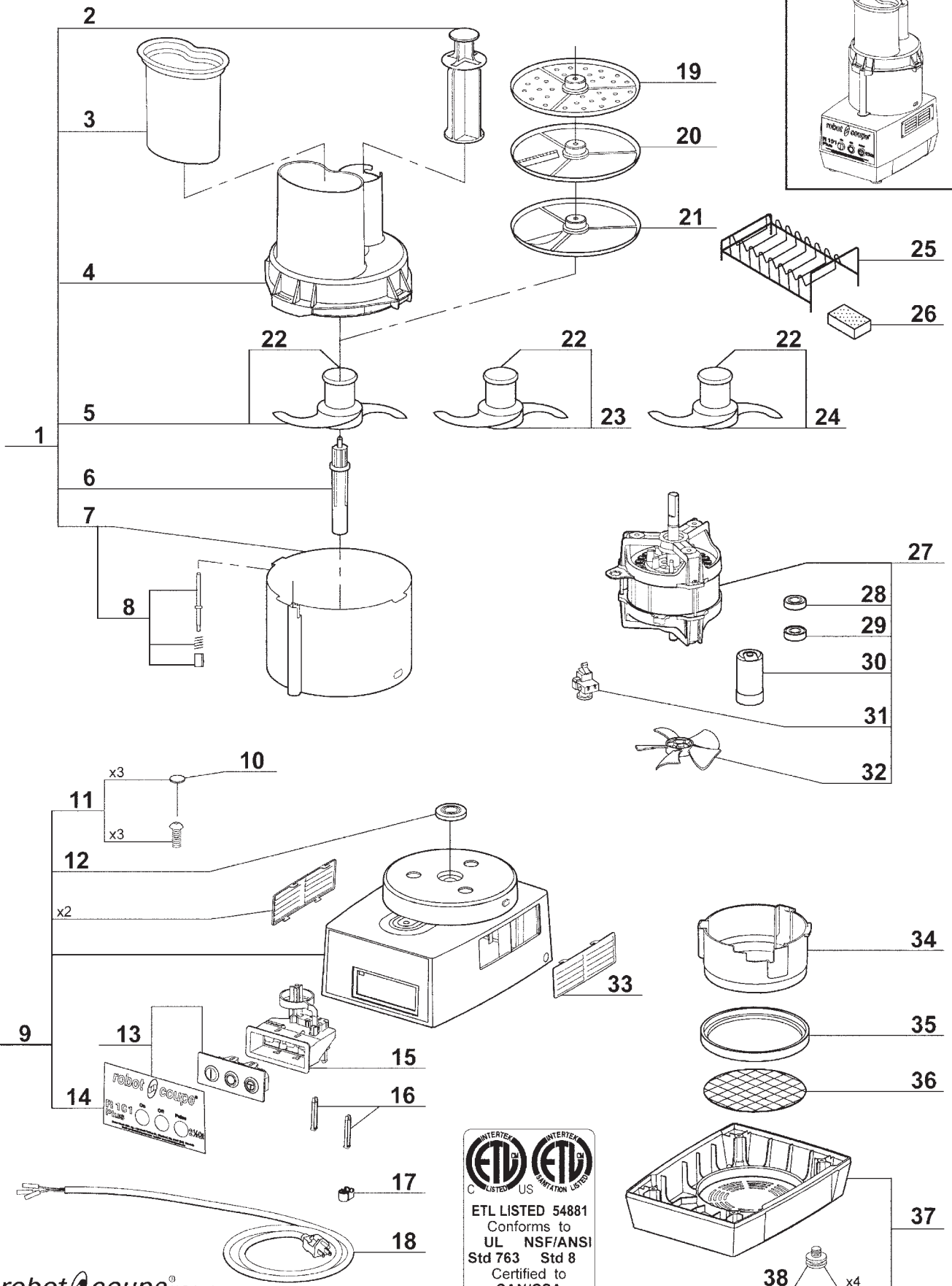

  
**ETL LISTED 54881**  
 Conforms to  
**UL NSF/ANSI**  
**Std 763 Std 8**  
 Certified to  
**CAN/CSA**  
**Std C22.2 No.195**

**robotcoupe**® U.S.A., Inc.

PH: 1-800-824-1646 FAX: 601-898-9134  
email: info@robotcoupeusa.com

Index	Pièce / Part	Description
1	27 399	CUTTER ATTACHMENT
2	119 162	ROUND PUSHER
3	112 216	VEGETABLE PUSHER
4	112 206	LID
5	27 054	SMOOTH BLADE
6	101 090	DISC STEM
7	117 900	CLEAR BOWL
8	29 900	COMPLETE SAFETY ROD
9	49 018	MOTOR SUPPORT ASSEMBLY
10	102 709	BOLT COVER
11	29 633	SCREW ASSEMBLY
12	501 010	MOTOR SEAL
13	49 019	COMPLETE ON / OFF / PULSE SWITCH ASSEMBLY
14	49 021	FRONT PLATE
15	39 877	SAFETY ASSEMBLY
16	39 876	PANEL KEY ASSEMBLY
17	49 000	POWER CORD CLIP
18	39 890	POWER CORD
19	27 577	GRATER 2 mm
20	27 610	JULIENNE 6x6
21	27 566	SLICER 4 mm
22	117 058	BLADE CAP
23	27 161	SERRATED BLADE
24	27 062	FINE SERRATED BLADE
25	R255	PLATE RACK
26	R248	SHARPENING STONE
27	3 216	MOTOR
28	504 229	UPPER BALL-BEARING 6002 2RS
29	600 457	LOWER BALL-BEARING 6201 2RS
30	603 669	STARTING CAPACITOR
31	500 296	STARTING RELAY
32	117 610	MOTOR FAN
33	104 122	VENTILATION GRID
34	101 097	VENTILATION BAFFLE
35	101 099	ABSORBER
36	103 761	VENTILATION SCREEN
37	102 697	BASE
38	39 928	FOOT (x4)

**MODEL R 101 Plus - R 101 B - R 121**  
ELECTRIC DIAGRAM

120V/60Hz SINGLE PHASE

ESQUEMA CONEXIONES

SCHEMA ELECTRIQUE

**R 101 Plus** Serial # : from 636XXXXX 03 E - MM  
**R 101 B** Serial # : from 639XXXXX 03 E - MM  
**R 121** Serial # : from 641XXXXX 03 F - MM

	English	Espanol	Français
CD	Starting capacitor	Condensador d'arranque	Condensateur de demarrage
EA	Starting phase	Fase auxiliar	Phase auxiliaire
EP	Main phase	Fase principal	Phase principale
KD	Starting relay	Rele d'arranque	Relais de demarrage
MA	ON / OFF - PULSE switch	Interruptor MARCHA / PARADA / IMPULSO	Interrupteur MARCHÉ / ARRÊT / PULSE
MO	Single phase Motor	Motor monofasico	Moteur monophasé
PTO	Motor thermal protector	Protector termico del motor	Protecteur thermique du moteur
SW	Lid safety switch	Interruptor de seguridad cojinete	Interrupteur sécurité couvercle

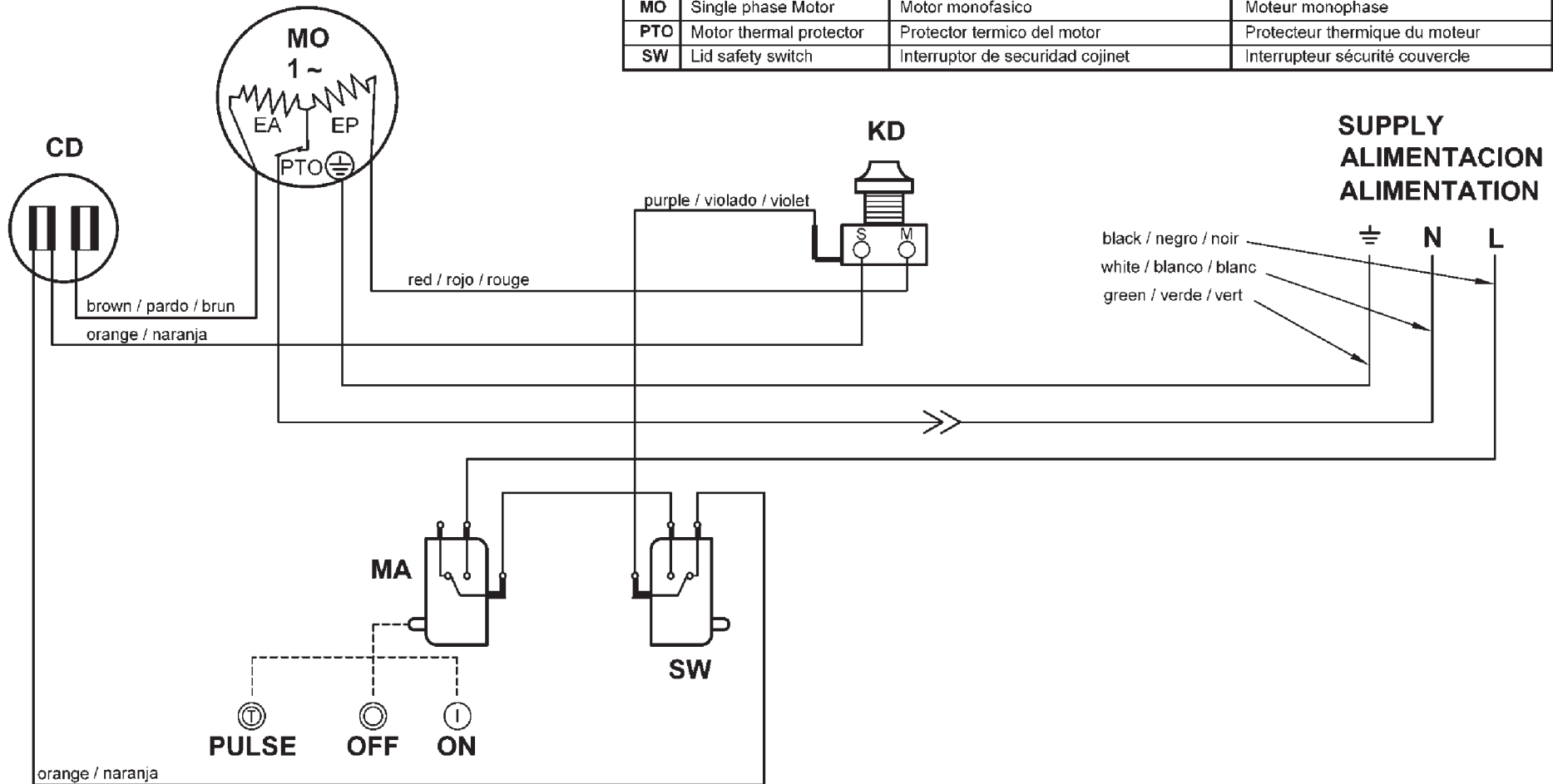

**MODEL R 100 - R 101 - C 40 Series A**  
ELECTRIC DIAGRAM

120V/60Hz SINGLE PHASE

ESQUEMA CONEXIONES

SCHEMA ELECTRIQUE

**R 100** Serial # : from 640XXXXX 03 E - MM  
**R 101** Serial # : from 635XXXXX 03 E - MM  
**C 40 Series A** Serial # : from 587XXXXX 03 E - MM

	English	Espanol	Français
CD	Starting capacitor	Condensador d'arranque	Condensateur de demarrage
EA	Starting phase	Fase auxiliar	Phase auxiliaire
EP	Main phase	Fase principal	Phase principale
KD	Starting relay	Rele d'arranque	Relais de demarrage
MA	ON / OFF switch	Interruptor MARCHA / PARADA	Interrupteur MARCHÉ / ARRÊT
MO	Single phase Motor	Motor monofasico	Moteur monophasé
PTO	Motor thermal protector	Protector termico del motor	Protecteur thermique du moteur
SW	Lid safety switch	Interruptor de seguridad cojinet	Interrupteur sécurité couvercle

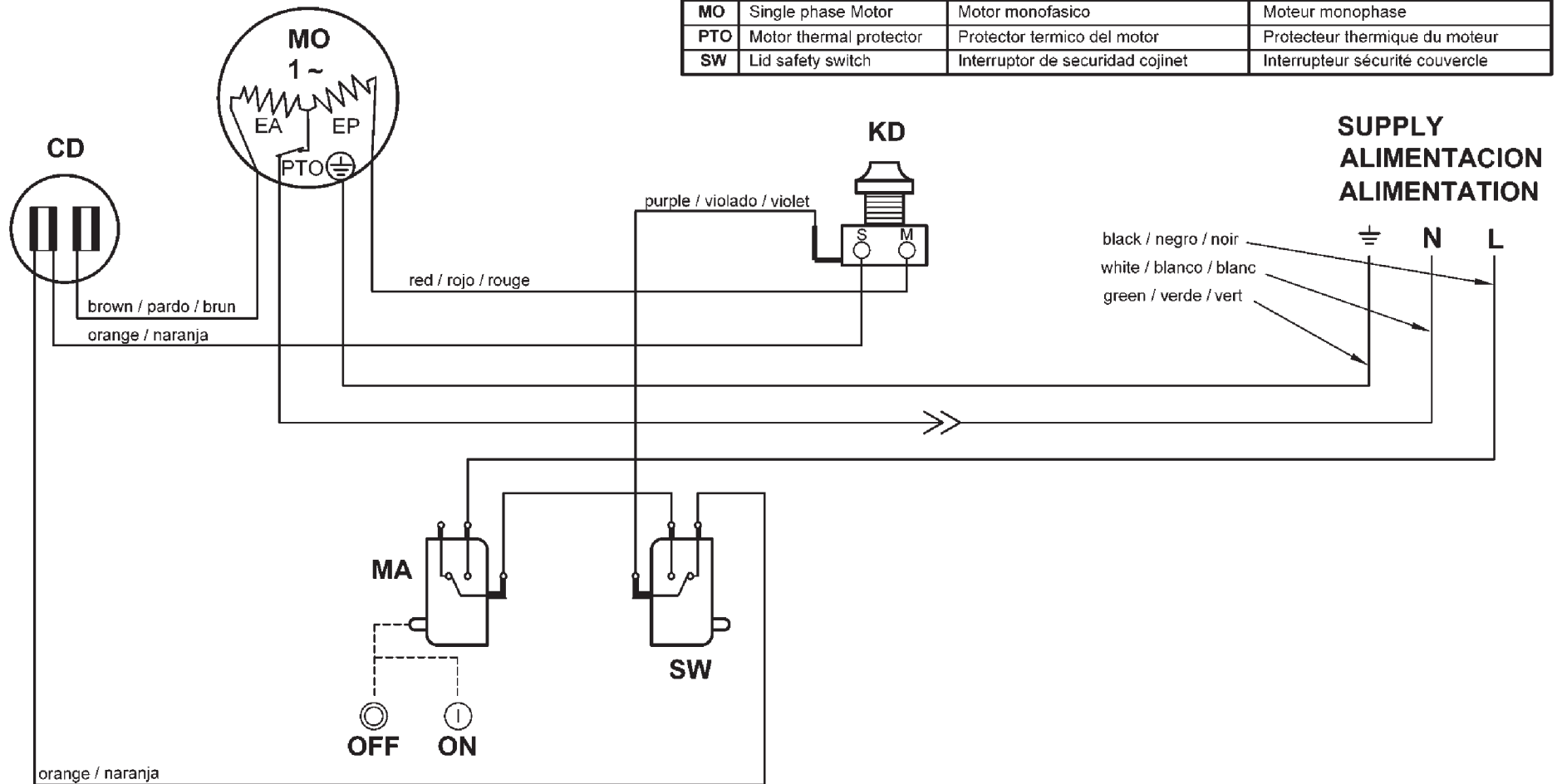





---

***robot coupe***<sup>®</sup>

**Robot-coupe USA. Inc.**

P.O. Box 16625, Jackson, MS 39236-6625

264 South Perkins St., Ridgeland, MS 39157

e-mail: [info@robotcoupeusa.com](mailto:info@robotcoupeusa.com)

website: [www.robotcoupeusa.com](http://www.robotcoupeusa.com)

Phone : 1-800-824-1646