

08.09.2010

L01- 151 Rev A

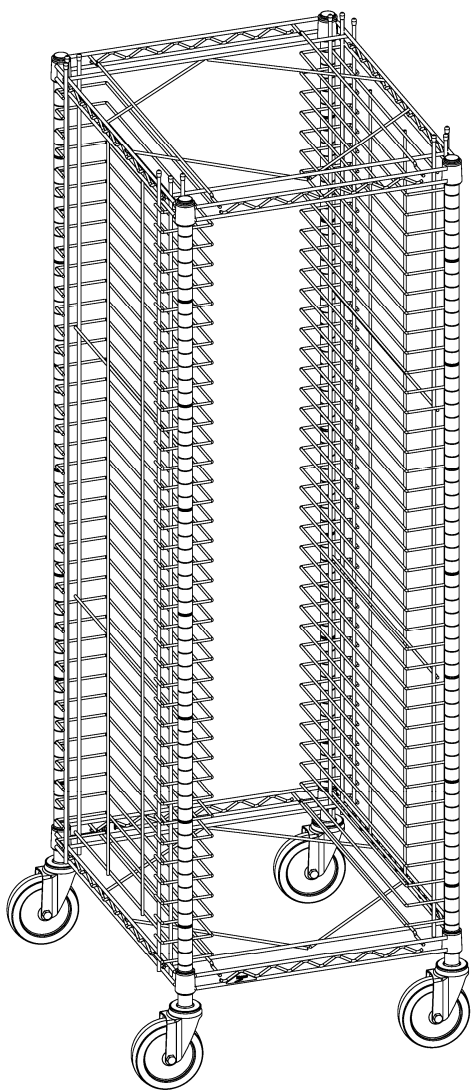

**END LOAD  
RE1, RE3**

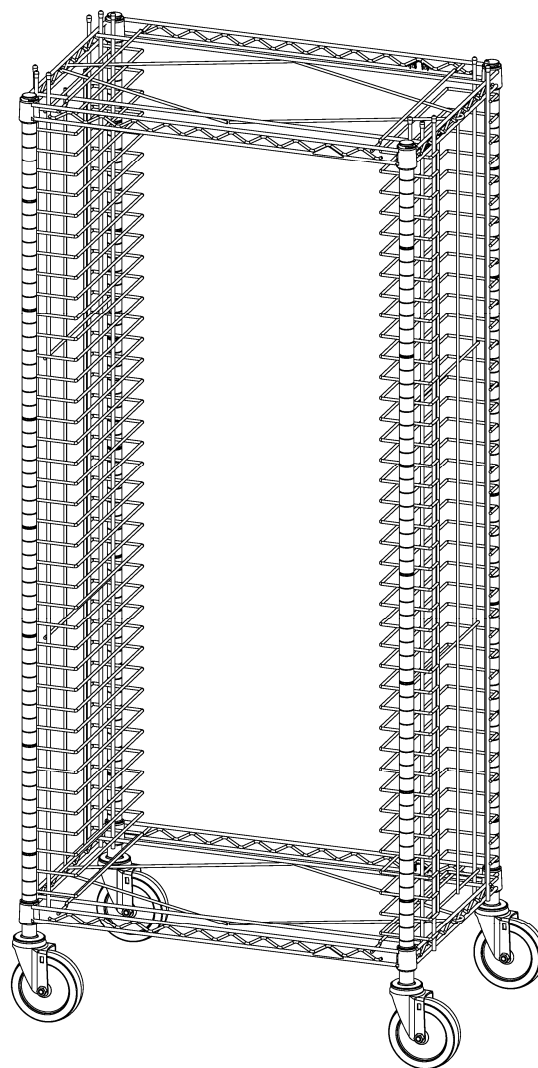

**SIDE LOAD  
RS1, RS3**

(Two People Required to Assemble)

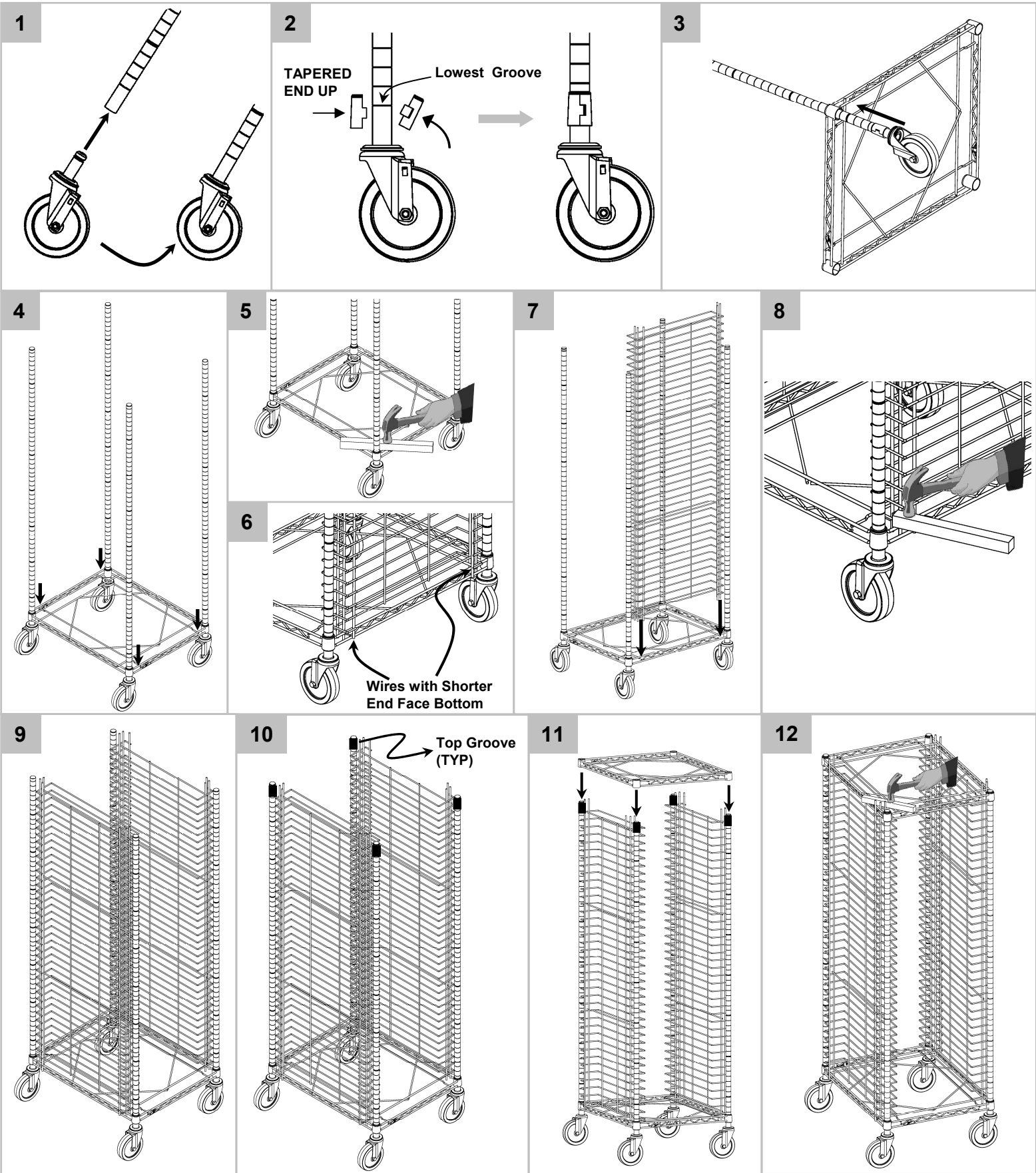

13

Retaining Ring (TYP)

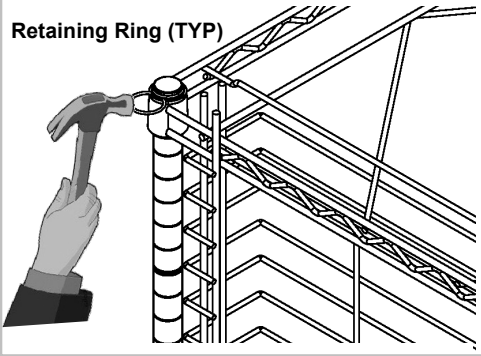
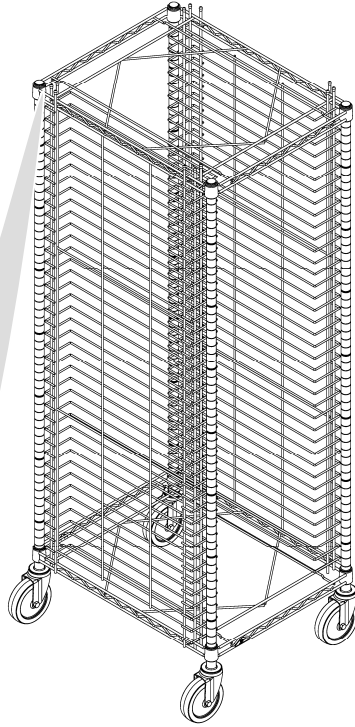
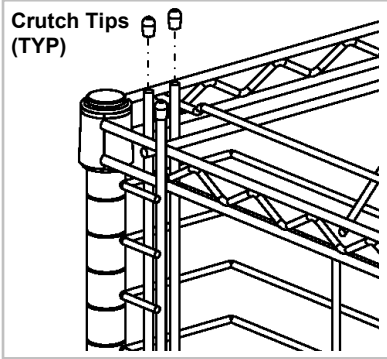
Crutch Tips  
(TYP)

Proper Assembly of Units from Top View

End Load (RE)

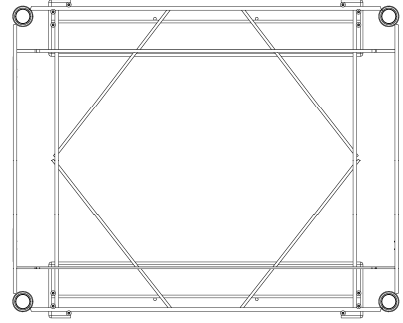

Side Load (RE)

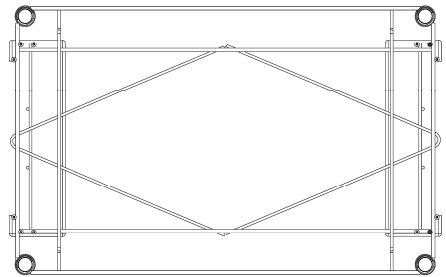

**THIS COMPLETES THE ASSEMBLY OF  
MODELS RE1, RE3, RS1, RS3  
BUN PAN RACK**