

Digital Countertop Conveyor Oven Series 2500

Installation, Operation and Maintenance Manual



Safety Notices

As you work on Lincoln equipment, be sure to pay close attention to the safety notices in this manual. Disregarding the notices may lead to serious injury and/or damage to the equipment.

Throughout this manual, you will see the following types of safety notices:

DANGER

Text in a Danger box alerts you to an eminent personal injury situation. Be sure to read the Danger statement before proceeding, and work carefully.

Warning

Text in a Warning box alerts you to a potential personal injury situation. Be sure to read the Warning statement before proceeding, and work carefully.

Caution

Text in a Caution box alerts you to a situation in which you could damage the equipment. Be sure to read the Caution statement before proceeding, and work carefully.

Procedural Notices

As you work on Lincoln equipment, be sure to read the procedural notices in this manual. These notices supply helpful information which may assist you as you work.

Throughout this manual, you will see the following types of procedural notices:

Important

Text in an Important box provides you with information that may help you perform a procedure more efficiently. Disregarding this information will not cause damage or injury, but it may slow you down as you work.

NOTE: Text set off as a Note provides you with simple, but useful, extra information about the procedure you are performing.

Read These Before Proceeding:

DANGER

Do not install or operate equipment that has been misused, abused, neglected, damaged, or altered/modified from that of original manufactured specifications.

Warning

Improper installation adjustment, alteration, service or maintenance can cause property damage, injury or death. Read the installation, operating and maintenance instructions thoroughly before installing, operating or servicing this equipment.

Warning

Authorized Service Representatives are obligated to follow industry standard safety procedures, including, but not limited to, local/national regulations for disconnection / lock out / tag out procedures for all utilities including electric, gas, water and steam.

Warning

This appliance is not intended for use by persons (including children) with reduced physical, sensory or mental capabilities, or lack of experience and knowledge, unless they have been given supervision concerning use of the appliance by a person responsible for their safety. Do not allow children to play with this appliance.

Warning

This equipment is intended for indoor use only. Do not install or operate this equipment in outdoor areas.

Warning

Do not use electrical appliances or accessories other than those supplied by the manufacturer.

FOR YOUR SAFETY

Do Not Store Or Use Gasoline Or Other Flammable Vapors Or Liquids In The Vicinity Of This Or Any Other Appliance.

Warning

Never use a high-pressure water jet for cleaning or hose down or flood interior or exterior of units with water. Do not use power cleaning equipment, steel wool, scrapers or wire brushes on stainless steel or painted surfaces.

Caution

Maintenance and servicing work other than cleaning as described in this manual must be done by authorized service personnel.

NOTE: Proper installation, care and maintenance are essential for maximum performance and trouble-free operation of your equipment. Visit our website www.mtwkitchencare.com for manual updates, translations, or contact information for service agents in your area.

Table of Contents

Section 1 General Information

Purchaser's Responsibility	5
Additional Requirements	5
Model Number Key	6

Section 2 Installation

Exterior Dimensions – Series 2500	7
Utility Specifications	7
Installation Requirements	8
Electrical Code Requirements.....	8
Spacing Requirements	8
Ventilation Requirements.....	8
Installation	8
Electrical Grounding Instructions.....	9
Assembly Instructions	9
Stacking Instructions	10
Mounting Instructions	10
Installation Checklist	11
Checklist	11

Section 3 Operation

Information on Use of Oven	13
Operating Instructions	14
Power-Up the Oven	14
Change Belt Direction	14
Shutdown.....	14
Programming	14
Programming the Four Menu Preset Buttons	14
Programming the Manual Mode	15

Section 4 Maintenance

Operator Maintenance	17
Daily Cleaning	17
Weekly Cleaning	17
Conveyor Removal & Reinstallation	18
Finger Removal & Disassembly for Cleaning	19
Disassembly	19
Disassemble Fingers for Cleaning	19
Reassembly.....	19
Preventive Maintenance	19

Section 5
Troubleshooting

Before Calling for Service Checklist21
Thermal Cut-Out Switch for Control Box Components21
How to Obtain Service21

Section 1

General Information

Purchaser's Responsibility

It is the responsibility of the purchaser to:

1. Confirm the electric services for the oven are installed on site in accordance with the manufacturer's specification.
2. Unload, uncrate, and install the oven in its proper location; in accordance with this installation/operation manual.
3. Confirm the electric services are connected properly by a qualified installer of your choice. All such connections must be in accordance with applicable code requirements. Refer to "Installation Requirements" section for specific information.

ADDITIONAL REQUIREMENTS

- Minimum clearances must be maintained from all walls and combustible materials. See "Spacing Requirements" section for more information.
- Keep the oven free and clear of combustible material.
- Adequate clearance for air openings to the control chamber on both sides of the oven is required.
- Do not obstruct the ventilation holes in the control boxes and covers, as these provide cooling air for the controls.
- The oven is to be operated only on the type of electricity as shown on the specification plate.
- This manual should be retained for future reference.
- The electrical wiring diagram is located under the control box covers.

Model Number Key

Example: 2501-000-U-0001620

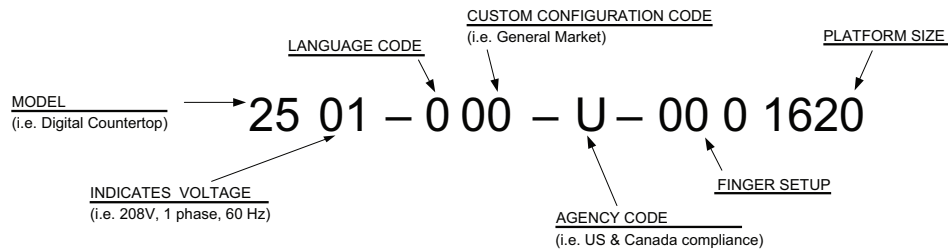

Language Code

Code	Language	Country
0	English	Dom. & Int. Default
B	French	CE – France/Luxembourg
C	German	CE – Germany
D	Italian	CE – Italy
E	Spanish	CE – Spain
F	English	CE – UK/India/Africa/Hungary
G	Spanish	Mexico/Latin America
H	Portuguese	CE – Portugal
I	Not Used	---
J	Danish	CE – Denmark
K	Dutch & French	CE – Belgium
L	Dutch	CE – Netherlands
M	Greek	CE – Greece
N	Finnish	CE – Finland
O	Restricted	---
P	Norwegian	CE – Norway
Q	English	Japan
R	Swedish	CE – Sweden
S	English	Australia
T	Mandarin	China
U	Restricted	---
V	English	Pacific Rim/Korea
W	English	Middle East/Africa
X	Not Used	---
Y	Not Used	---
Z	Not Used	---

Agency Code

Code	Agency
N	No agency
E	CE & RoHS compliance combined
U	US & Canada compliance only
A	Advantage style oven
B	Australia AGA

Section 2 Installation

Exterior Dimensions – Series 2500

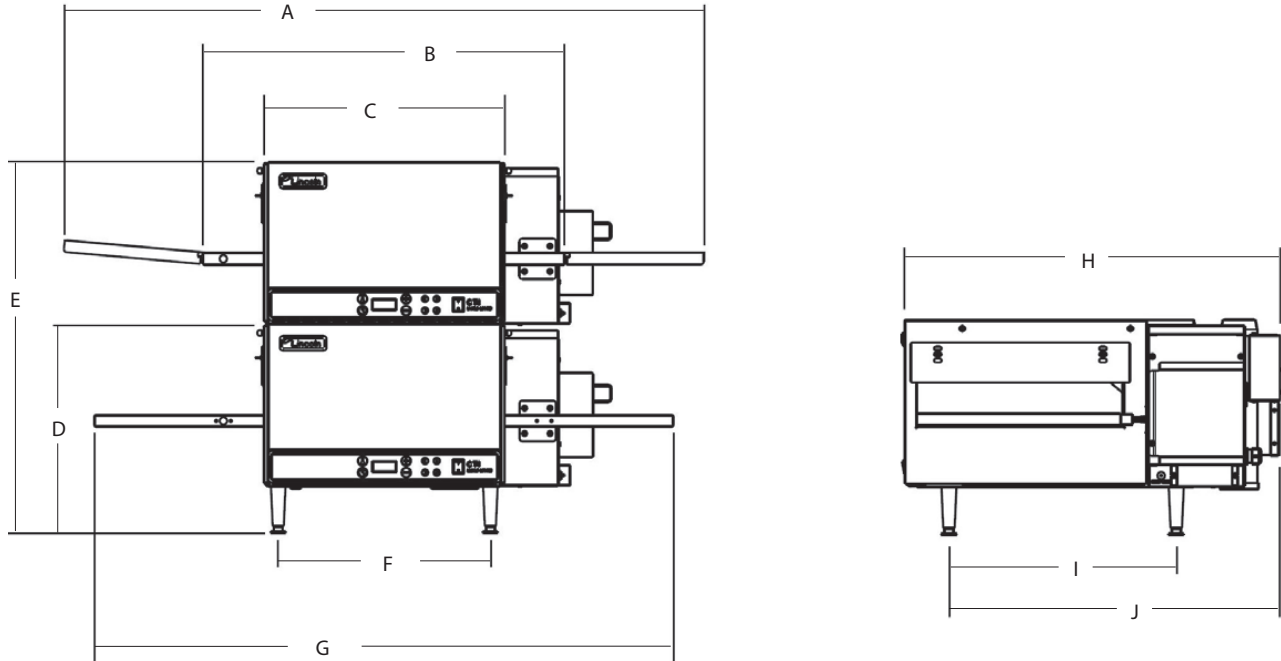

	A*	B**	C	D	E	F	G***	H	I	J
Inches	51.125	31.10	20.50	17.9375	31.875	18.25	49.75	31.25	18.9375	27.50
(mm)	(1298.6)	(789.9)	(520.7)	(455.6)	(809.6)	(463.6)	(1263.7)	(793.8)	(481.0)	(698.5)

* A dimension pertains to a unit with standard conveyor and 12" (304 mm) take-off shelves included on each end.

** B dimension pertains to a unit with standard length conveyor.

*** G dimension pertains to a unit with an extended conveyor only.

Utility Specifications

Model No.	Motor RPM	Input Rate	Voltage	Amps	Hz	Phase	No. of wires
2501-000	3100	6 kW	208	27	60	1	3
2501-001 (Quiet)	1750	6 kW	208	27	60	1	3
2502-000	3100	6 kW	240	24	60	1	3
2502-001 (Quiet)	1750	6 kW	240	24	60	1	3
2504-000	3100	6 kW	240	24	50	1	3
2504-001 (Quiet)	1750	6 kW	240	24	50	1	3
2505-000	3100	6 kW	380/220	15	50	1	4
2507-000	3100	6 kW	200	16	50/60	3	5
2508-000	3100	6 kW	380/220	9	50	3	5
2509-000	3100	6 kW	415/240	8	50	3	5
2510-000	3100	6 kW	220	27	60	1	3
2512-000	3100	6 kW	400/230	9	50	3	5
2512-004	3100	6 kW	400/230	9	50	3	5
2514-000	3100	6 kW	240	24	50	1	3

NOTE: Specifications subject to change without notice.

NOTE: Do not install this (these) oven(s) in any area with an ambient temperature in excess of 95°F (35°C). Doing so will cause damage to unit.

Installation Requirements

DANGER

All utility connections and fixtures must be maintained in accordance with local and national codes.

ELECTRICAL CODE REQUIREMENTS

Warning

This appliance must be grounded and all field wiring must conform to all applicable local and national codes. Refer to rating plate for proper voltage. It is the responsibility of the end user to provide the disconnect means to satisfy the authority having jurisdiction.

Warning

This equipment must be positioned so that the plug is accessible unless other means for disconnection from the power supply (e.g., circuit breaker or disconnect switch) is provided.

Caution

In order to avoid a hazard due to inadvertent resetting of the thermal cutout, this appliance must not be supplied through an external switching device, such as a timer or connected to a circuit that is regularly switched on and off by the utility.

IN USA: When installed, this appliance must be electrically grounded and its installation must comply with the National Electric Code, ANSI-NFPA 70, latest edition, the manufacturers' installation instructions, and applicable local municipal building codes.

IN CANADA: All electrical connections are to be made in accordance with CSA C22.21 latest version – Canadian Electrical Code Part 1 and/or local codes.

ALL OTHER COUNTRIES: Local electrical codes will prevail.

1. Strain relief is provided with each oven. International Dealer/Distributors provide applicable power cord/plug for each customer.
2. All pole disconnection switch must have 3 mm open contact distance.
3. To prevent electrical shock, an equal potential bonding ground lug is provided in the back. This allows the oven to be connected to an external bonding system.
4. If used as double-stack and each oven has its own disconnection switch, all switches should be close together.

SPACING REQUIREMENTS

The oven must have 6 inches (152 mm) of clearance from combustible surfaces. In case other equipment is located on the right side of oven, a minimum clearance of 24 inches (609 mm) is required from that equipment.

FOR ALL OVENS: A 24-inch (609 mm) clearance at the rear of the oven must be obtainable for service access.

VENTILATION REQUIREMENTS

Local codes prevail. These are the authority having jurisdiction as stated by the NATIONAL FIRE PROTECTION ASSOCIATION, INC. in NFPA 96 latest edition.

Installation

The instructions that follow are intended as a guide for preparing for the installation of the Countertop Conveyor oven. First and foremost, each crate should be examined before signing the Bill of Lading to report any visible damage caused during shipment in transit, and to account for the proper number of crates.

IF THERE IS APPARENT DAMAGE:

UNITED STATES AND CANADA: Arrangements should be made to file a claim against the carrier, as Interstate Commerce Regulations require that the consignee initiate a claim.

ALL SHIPMENTS TO OTHER COUNTRIES: Freight terms will be developed and extended on an individual basis.

Proper and secure storage facilities should be arranged for the oven(s). If necessary, protect it from outdoor or damp conditions at all times before installation.

ELECTRICAL GROUNDING INSTRUCTIONS

**⚠ Warning
Domestic**

As it pertains to domestic model units, this appliance is equipped with a three-prong (grounding) plug for your protection against shock hazard and should be plugged directly into a properly grounded three-prong receptacle. Do not cut or remove the grounding prong from this plug.

**⚠ Warning
International (CE)**

This appliance must be properly grounded at time of installation. Failure to ensure that this equipment is properly grounded can result in electrocution, dismemberment or fatal injury.

⚠ Warning

If the supply cord appears to be damaged, do not attempt to operate unit. Contact a service agent or qualified electrician to repair.

Assembly Instructions

Install legs as shown.

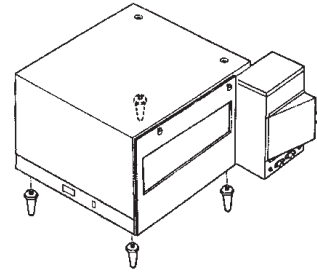

⚠ Caution

Legs **MUST** be installed to ensure proper operation! Failure to do so will result in damage to unit and denied warranty claims.

⚠ Caution

Oven must be operated on an approved base only. When utilizing a double-stack configuration of ovens, the bottom unit must always be mounted on the legs provided.

⚠ Caution

Before applying power to the oven, check to ensure that the finger assemblies and air duct panels (upper and lower) are properly seated and have not become dislodged during shipment.

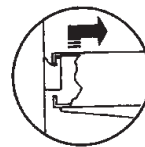

Front of Finger Assembly Properly Installed

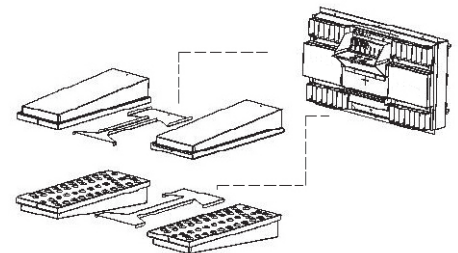

Cut-away view of interior baking chamber noting Finger and Plenum installation

Stacking Instructions

FOR SINGLE AND DOUBLE STACK UNITS

Important

When stacking ovens, be sure to remove the bottom flue cap from top oven.

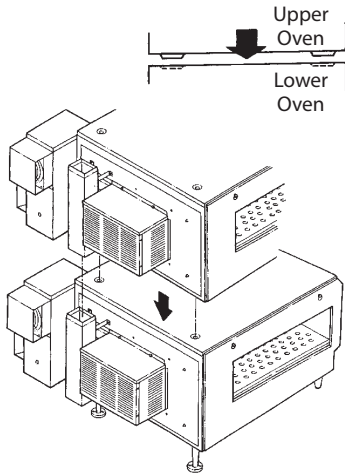

Caution

If stacking configuration consists of both analog (1300 Series) and digital (2500 Series) units, always stack the digital (2500 Series) unit on top. Incorrect stacking arrangement may damage both ovens!

NOTE: When utilizing a double-stack configuration, stack the ovens so that the small foot on the top oven fits into the indentation on the top of the bottom oven.

Caution

If you utilize a double-stack configuration, please note that each oven has its own disconnect switch. Make sure that all switches are in the OFF position before beginning maintenance or cleaning.

Mounting Instructions

Position the oven on the countertop and carefully mark the position of the rear legs. Remove the oven from the countertop and position the mounting rings so that the large (center) hole is where the legs of the oven were marked. Mark the position of the two small holes and remove the mounting rings.

When installing on a heavy stainless steel or wood countertop, use the four 3/16" x 9/32" drive rivets. Use a 0.218" diameter drill (7/32") and drill at least 1/2" into a wood countertop or all the way through a steel countertop so that the rear legs are in the large holes in the mounting ring.

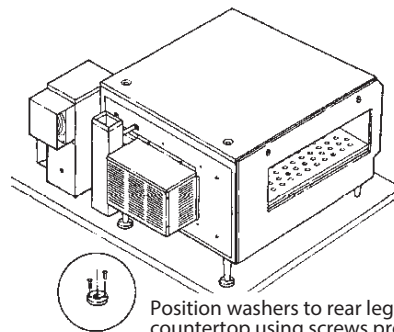

Position washers to rear legs, anchor them to countertop using screws provided.

Caution

Install this unit in the most convenient locations for ease of cleaning, maintenance, and general operation. Avoid installing in locations with drafts, close proximity to grease or vapor-producing appliances or other high-ambient heat equipment.

Installation Checklist

⚠ DANGER

Check all wiring connections, including factory terminals, before operation. Connections can become loose during shipment and installation.

CHECKLIST

- Are the correct clearances maintained?
- Does the ventilation system meet the requirements?
- Is the unit level?
- Is the unit is grounded?
- Have all wiring connections including the factory connections been checked?
- Has the supply voltage been tested and verified it matches the name plate voltage?
- Are the finger assemblies correctly installed and positioned?
- Has the unit been tested for correct operation?
- Has the owner been instructed in the correct operation of the unit?
- Has this manual been given to the store owner?

THIS PAGE INTENTIONALLY LEFT BLANK

Section 3 Operation

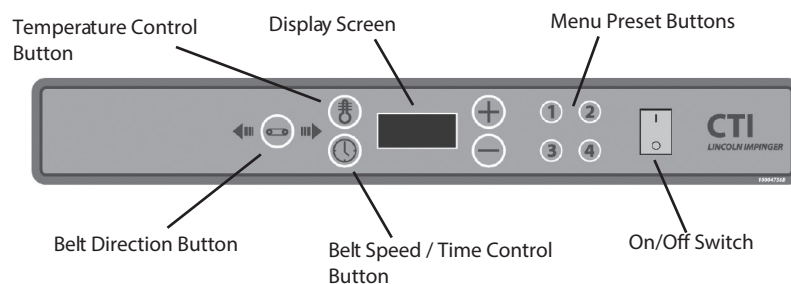

Digital Display Control Panel

Information on Use of Oven

The Countertop Impinger® oven functions by directing high velocity streams of heated air directly on the food products. Because air is the heat source, it is effective even on sensitive foods. Compared to conventional ovens and even convection ovens, the cooking time of products in the Countertop Impinger® ovens can be as much as two to four times faster. Several factors may affect the cooking time of any special product such as oven temperature setting and conveyor speed.

We encourage you to experiment with the oven by trying different temperature settings and conveyor speeds.

Warning

Do not work around conveyor with long hair, loose clothing, or dangling jewelry. Getting caught in the belt could result in serious injury.

Warning

Do not spray aerosols in the vicinity of this appliance while it is in operation.

Warning

If the power supply cord appears to be damaged, do not attempt to operate the unit. Contact a service agent or qualified electrician to repair!

Warning

Do not use parchment paper when placing food product through the appliance! Use of such materials may cause a fire and should never be placed in the appliance.

Operating Instructions

Prior to operating your new countertop oven, it is important to understand the options available to you. Following is a chart to better illustrate these options.

Controls	Description
Belt Speed / Time Control	Belt speed refers to how quickly the food item travels through the oven. This is shown on the display board as a unit of measure (fast to slow) between :30 seconds and 15:00 minutes.
Temperature Control	The countertop oven will allow you to increase or decrease the desired temperature setting. This is shown on the display board as a unit of measure between 90°F (32°C) - 600°F (316°C).
Belt Direction	The Countertop Oven will allow you to change the direction in which the conveyor belt moves. Pressing the Belt Direction Button will change the direction of travel between left-to-right and right-to-left options.

POWER-UP THE OVEN

1. Turn the on/off switch to the ON position. The oven will now run according to the previously programmed settings.



2. Allow the oven to preheat for approximately 30 minutes.

CHANGE BELT DIRECTION

Press the belt direction button to change the direction in which the conveyor belt travels.

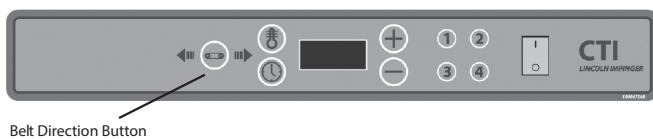

SHUTDOWN

1. Push the on/off switch to the OFF position.
2. As each countertop oven is equipped with a 30-minute cool-down timer, the fan motor will continue to run for 30-minutes after the unit has been turned off. The fan motor will automatically stop at the end of the 30-minute cool-down period.

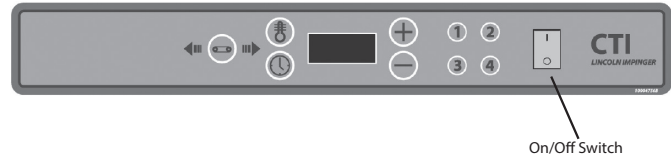

Programming

PROGRAMMING THE FOUR MENU PRESET BUTTONS

1. Press and hold the desired menu button (1-4) for approximately 5 seconds. The display screen will flash the temperature setpoint. Press the (+) or (-) button to reach the desired temperature.

NOTE: All menu presets come with default settings of Pizza at 550°F / 6:00.



2. Press and release the menu button again to reach the time/belt speed setpoint. The display will flash the time/belt speed setpoint. Press the (+) or (-) button to reach the desired time/belt speed.
3. Press and release the menu button again to reach the menu item name. The display will flash a menu item name. Press the (+) or (-) button to locate the desired name.

NOTE: The following menu items have been preset into the software package of this oven.

- Pizza
- Wings
- Breakfast
- Breadsticks
- Thin Pizza
- Sandwich
- Chicken
- Snack
- Lunch
- Dinner
- Wrap
- Menu 1
- Menu 2
- Menu 3
- Menu 4

4. Once the desired name has been selected, press and release the menu button again to activate the menu setting.

PROGRAMMING THE MANUAL MODE

1. Press and hold the time and temperature buttons for approximately 5 seconds to enter manual mode.

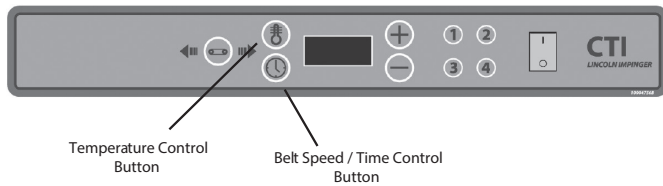

2. Press the time button to allow for changes in time. Press the (+) or (-) button to reach the desired time.
3. Press and release the temperature button to allow for changes in temperature. Press the (+) or (-) button to reach the desired temperature.

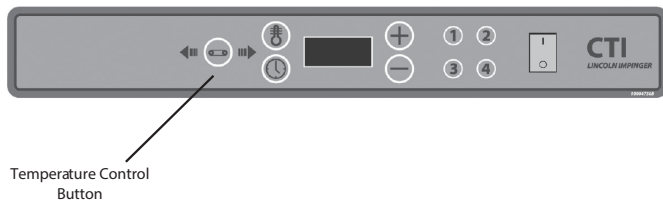

4. Press and release the temperature button again to leave manual mode and activate the manual settings.

THIS PAGE INTENTIONALLY LEFT BLANK

Section 4 Maintenance

Operator Maintenance

Warning

Disconnect power supply before servicing or cleaning this oven. Safeguard power so it cannot be accidentally restored. Failure to do so could result in dismemberment, electrocution, or fatal injury.

The Lincoln Countertop Impinger® Oven contains electrical components. Before cleaning the oven, switch off and disconnect the oven from the electrical supply.

No electrical components should be subjected to moisture. Therefore, it is important the oven is wiped down carefully. NEVER throw buckets of water over the oven or subject it to pressure washing from a hose or a pressure spray. If water or other liquid is spilled on the oven, make sure that none has entered the control box area before switching on. If in doubt, call your service company.

To achieve the maximum efficiency of the oven, it is necessary to keep it clean. The frequency listed is only the factory's recommendation. Your use and type of products will actually determine the frequency of cleaning.

Caution

Oven must be cool. Do not use power-cleaning equipment, steel wool, or wire brushes on stainless steel surfaces.

Daily Cleaning

1. Clean exterior surfaces of the oven by wiping it down with a mild detergent and clean water, or a commercial stainless steel cleaner.
2. Clean the interior by sweeping up all loose particles, then wash with a mild detergent solution and rinse with clean water.
3. Clean the conveyor belt by wiping with a clean, water-dampened cloth to remove any baked on crust or food product.

Caution

Do not use caustic or alkaline base cleaner on interior of oven. This will ruin the aluminized finish of the oven interior. On exterior of oven, removal of deposits of baked-on splatter, oil, grease, or light discolorations may be removed with any of several commercial cleaners. Consult with your local supplier.

Warning

When using cleaning solutions, be sure they meet local and national health standards.

Weekly Cleaning

1. Remove conveyor, disassemble and clean. See Conveyor Removal section for more information.
2. Remove fingers, disassemble and clean. See Finger Removal section for more information.

Conveyor Removal & Reinstallation

 **Caution**

Conveyor and belt may be hot!

1. Remove extension shelves (if applicable).

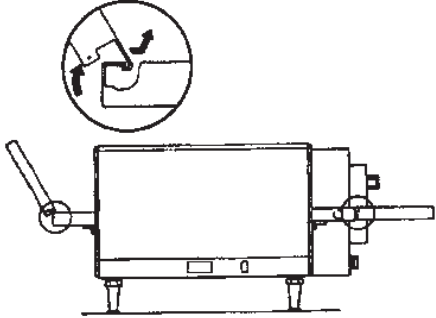

2. Push coupling away from drive lugs.

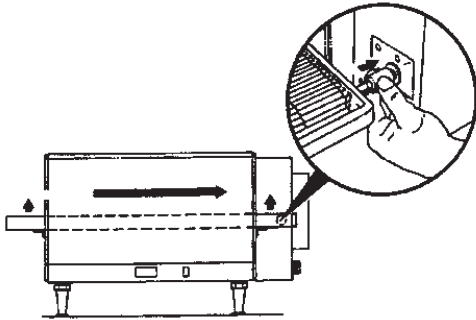

3. Remove conveyor from oven cavity.

4. Reassemble in reverse order.

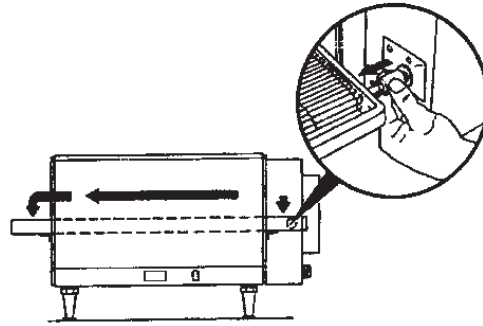

5. Install extension shelves (if applicable).

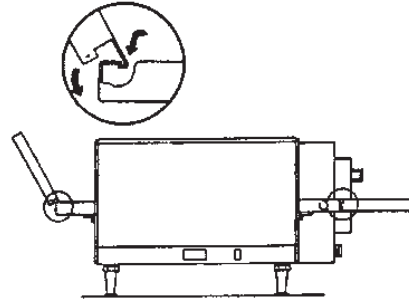

Finger Removal & Disassembly for Cleaning

DISASSEMBLY

1. Remove 1/4-20 thumbscrews (2 per panel) then pull back the panel.
2. Lift panel off lower retaining tabs.

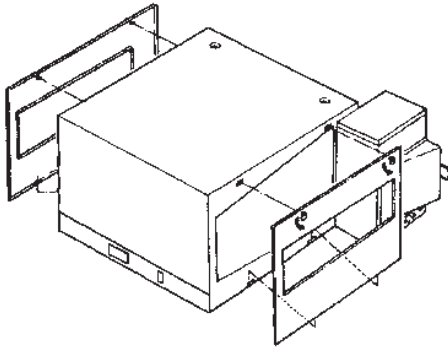

3. Lift finger assembly to clear hanger on front wall of oven. Then slide to the rear and swing out.

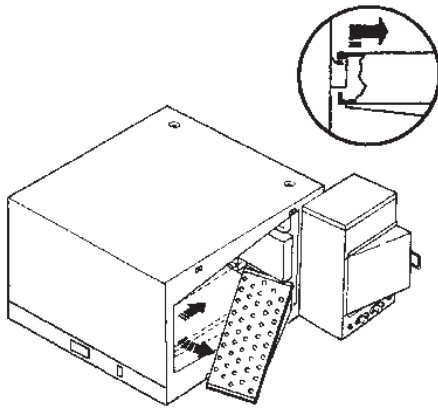

4. Remove finger assembly from oven.

DISASSEMBLE FINGERS FOR CLEANING

Slide finger cover from housing. Lift out inner columnating plate.

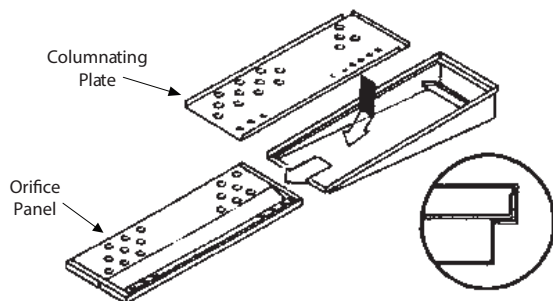

REASSEMBLY

1. Reassemble in reverse order.

NOTE: Check to ensure that the holes in the columnating plate are lined up with the holes in the orifice panel.

2. Reinstall fingers in the oven. Be sure that they are fully seated over the plenum flanges and the holes are pointing toward the conveyor.
3. Reinstall cover panels (see Disassembly).

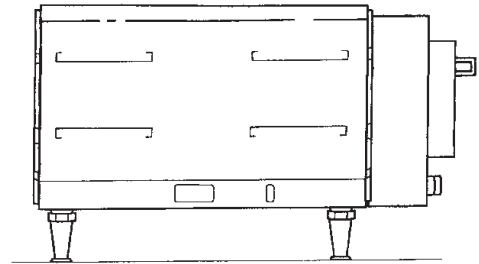

Finger covers are matched and may be installed in any location

Preventive Maintenance

Although this oven has been designed to be as trouble-free as possible, periodic preventive maintenance is essential to maintain peak performance. It is necessary to keep the motors, fans, and electronic controls free of dirt, dust and debris to ensure proper cooling. Overheating is detrimental to the life of all components mentioned. The periodic intervals for preventive cleaning may vary greatly depending on the environment in which the oven is operating. You must discuss the need for preventive maintenance with your Authorized Service Agency to establish a proper program. If there are any questions that the service agency cannot answer, please contact the KitchenCare Technical Service Department at (844) 724-2273.

THIS PAGE INTENTIONALLY LEFT BLANK

Section 5

Troubleshooting

Before Calling for Service Checklist

Problem	Cause	Correction
Doesn't operate	Breaker tripped	Reset breaker
	Safety thermal cut-out trips	Reset power, call for service if it repeats
	Fuses not good	Replace fuses on the back panel
Uneven heating	Fingers incorrectly assembled	Reassemble correctly
	Fingers in wrong location	Place fingers in correct location
Over or under cooked	Incorrect temperature setting	Adjust temperature
	Incorrect conveyor speed	Adjust conveyor speed
	Defective thermostat	Call for service
Conveyor does not operate	Incorrectly installed	Verify installation is correct - Call for service
	Conveyor has stretched from use	Call for service

Thermal Cut-Out Switch for Control Box Components

These ovens include a "safety thermal cut-out switch" for your protection. This safety related device is designed to ensure that the unit will not overheat and damage the oven. In the unlikely event that the oven would exceed the specified operating temperature range, the "safety thermal cut-out switch" will activate, thus blocking power to the unit and causing it to turn off.

 **Caution**

In order to avoid a hazard due to inadvertent resetting of the thermal cutout, this appliance must not be supplied through an external switching device, such as a timer or connected to a circuit that is regularly switched on and off by the utility.

How to Obtain Service

The name and phone number of the Authorized Service Agency should be located on the oven or contact the KitchenCare Technical Service Department at (844) 724-2273 for the name of the nearest agency.

THIS PAGE INTENTIONALLY LEFT BLANK

LIMITED WARRANTY FOR COMMERCIAL PRODUCTS

LIMITED WARRANTY

Lincoln Foodservice Products, LLC ("Lincoln") warrants this product to be free from defects in material and workmanship for a period of one (1) year from the date of purchase.

During the warranty period, Lincoln shall, at Lincoln's option, repair, or replace parts determined by Lincoln to be defective in material or workmanship, and with respect to services, shall re-perform any defective portion of said services. The foregoing shall be the sole obligation of Lincoln under this Limited Warranty with respect to the equipment, products, and services. With respect to equipment, materials, parts and accessories manufactured by others, Lincoln's sole obligation shall be to use reasonable efforts to obtain the full benefit of the manufacturer's warranties. Lincoln shall have no liability, whether in contract, tort, negligence, or otherwise, with respect to non-Lincoln manufactured products.

WHO IS COVERED

This Limited Warranty is available only to the original purchaser of the product and is not transferable.

EXCLUSIONS FROM COVERAGE

- Repair or replacement of parts required because of misuse, improper care or storage, negligence, alteration, accident, use of incompatible supplies or lack of specified maintenance shall be excluded
- Normal maintenance items, including but not limited to, light bulbs, fuses, gaskets, O-rings, interior and exterior finishes, lubrication, conveyor belt, motor bushes, broken glass, etc. adjustments and calibrations for temperatures, speed and air flows
- Failures caused by improper or erratic voltages
- Improper or unauthorized repair
- Changes in adjustment and calibration after ninety (90) days from equipment installation date
- This Limited Warranty will not apply to any parts subject to damage beyond the control of Lincoln, or to equipment which has been subject to alteration, misuse or improper installation, accidents, damage in shipment, fire, floods, power changes, other hazards or acts of God that are beyond the control of Lincoln
- This Limited Warranty does not apply, and shall not cover any products or equipment manufactured or sold by Lincoln when such products or commercial equipment is installed or used in a residential or non-commercial application. Installations not within the applicable building or fire codes render this Limited Warranty and any responsibility or obligations associated therein null and void. This includes any damage, costs, or legal actions resulting from the installation of any Lincoln commercial cooking equipment in a non-commercial application or installation, where the equipment is being used for applications other than those approved for by Lincoln.

LIMITATIONS OF LIABILITY

The preceding paragraphs set forth the exclusive remedy for all claims based on failure of, or defect in, products or services sold hereunder, whether the failure or defect arises before or during the warranty period, and whether a claim, however instituted, is based on contract, indemnity, warranty, tort (including negligence), strict liability, implied by statute, common-law or otherwise, and Lincoln, its servants and agents shall not be liable for any claims for personal injuries, incidental or consequential damages or loss, howsoever caused. Upon the expiration of the warranty period, all such liability shall terminate. THE FOREGOING WARRANTIES ARE EXCLUSIVE AND IN LIEU OF ALL OTHER WARRANTIES, WHETHER WRITTEN, ORAL, IMPLIED OR STATUTORY. NO IMPLIED WARRANTY OF MERCHANTABILITY OR FITNESS FOR PARTICULAR PURPOSE SHALL APPLY. LINCOLN DOES NOT WARRANT ANY PRODUCTS OR SERVICES OF OTHERS.

REMEDIES

The liability of Lincoln for breach of any warranty obligation hereunder is limited to: (i) the repair or replacement of the equipment on which the liability is based, or with respect to services, re-performance of the services; or (ii) at Lincoln's option, the refund of the amount paid for said equipment or services.

Any breach by Lincoln with respect to any item or unit of equipment or services shall be deemed a breach with respect to that item or unit or service only.

WARRANTY CLAIM PROCEDURE

Customer shall be responsible to:

- Immediately advise the Dealer or Lincoln's Authorized Service Agent of the equipment serial number and the nature of the problem.
- Verify the problem is a factory responsibility. Improper installation or misuse of equipment, are not covered under this Limited Warranty.
- Cooperate with the Service Agency so that warranty service may be completed during normal working hours.
- No travel over 200 miles (roundtrip) or three hours will be paid without an authorization number provided by Lincoln.

GOVERNING LAW

Limited Warranty shall be governed by the laws of the state of Delaware, USA, excluding their conflicts of law principles. The United Nations Convention on Contracts for the International Sale of Goods is hereby excluded in its entirety from application to this Limited Warranty.

Lincoln Foodservice Products, LLC
1111 North Hadley Road
Fort Wayne, Indiana 46804
USA
www.lincolnfp.com



Every new piece of Manitowoc Foodservice equipment comes with KitchenCare™ and you choose the level of service that meets your operational needs from one restaurant to multiple locations.

StarCare – Warranty & lifetime service, certified OEM parts, global parts inventory, performance audited

ExtraCare – CareCode, 24/7 Support, online/mobile product information

LifeCare – Install & equipment orientation, planned maintenance, KitchenConnect™, MenuConnect

Talk with KitchenCare™ • 1-844-724-CARE • www.mtwkitchencare.com



To learn how Manitowoc Foodservice and its leading brands can equip you, visit our global web site at www.manitowocfoodservice.com, then discover the regional or local resources available to you.

