

INSTRUCTIONS



LXe SERIES DISHWASHER

LXe SERIES DISHWASHER



MODELS

<i>LXeC</i>	<i>ML-130191</i>
<i>LXeH</i>	<i>ML-130192</i>
<i>LXePR</i>	<i>ML-130193</i>
<i>LXeR</i>	<i>ML-130194</i>

HOBART

701 S. RIDGE AVENUE
TROY, OHIO 45374-0001

937 332-3000

www.hobartcorp.com

FORM 38404 Rev. A (March 2013)

TABLE OF CONTENTS

GENERAL	4
INSTALLATION	5
Unpacking	5
Location	5
Leveling	5
Water Requirements	5
Plumbing Connections	6
Electrical Connection	7
Electrical Data	7
Connection Method	8
Detergent and Rinse Aid	9
Chemical Sanitizer (LXeC & LXePR)	10
Checking Sanitizer Concentration	10
Deliming Solution	10
Priming Chemical Pumps	11
Installation Diagram (LXeC)	12
Installation Diagram (LXeH)	13
Installation Diagram (LXePR)	14
Installation Diagram (LXeR)	15
PROGRAMMING.....	16
Manager Mode Programming	16
Programming Instructions	16
Menu Display Prompts	16
LXe Manager Mode Programming Card	17
LXe advansys Manager Mode Programming Card	19
Parameters Menu Table	21
OPERATION.....	23
Before First Use	23
Controls	23
Operating the LXe Dishwasher.....	24
Diagnostic/Error Messages	25
Wash/Rinse Cycle Times (LXeC and LXeH).....	26
Wash/Rinse Cycle Times (LXePR and LXeR).....	26
Preparation	26
Do's and Don'ts For Your New Hobart Dishwasher	27
CLEANING	28
MAINTENANCE	29
Deliming	29
Lubrication	29
TROUBLESHOOTING	30

Installation, Operation and Care of LXe SERIES DISHWASHERS

SAVE THESE INSTRUCTIONS



GENERAL

The LXe Series dishwashers are fully automatic, front-loading dishwashing machines. The LXe series machines are capable of doing 24 to 34 racks per hour, depending on model.

All LXe Series dishwashers shut down automatically 4 hours after last use to conserve energy.

All LXeH and LXeR dishwashers include *Sense-A-Temp*[™] to insure proper hot water temperature during rinse.

Standard equipment includes two 20" x 20" racks, electronic controls, drain pump, rinse pump, chemical pumps, fill hose, and drain hose.

MODEL	DESCRIPTION
LXeC, LXePR	Fresh water rinse; low-temperature, chemical-sanitizing models for use with 6% sodium hypochlorite solution (bleach) as the sanitizing agent*. Note: If 8.40% bleach is to be used, contact Hobart Service or your chemical supplier to change the sanitizer pump settings. (Charges may apply)
LXeH	Fresh water rinse with a built-in 70°F rise booster heater. This allows an incoming water temperature of 110°F.
LXeR	Fresh water rinse with an internal energy recovery unit and a built-in 70°F rise booster heater. Recommended incoming water temperature 55°F to 80°F.

* - Sanitizing agent must be used in accordance with the EPA-registered label use instructions.

INSTALLATION

UNPACKING

Immediately after unpacking the dishwasher, check for possible shipping damage. If this machine is found to be damaged, save packaging material and contact the carrier within 15 days of delivery.

LOCATION

Prior to installation, verify that the electrical supply agrees with the specifications on the machine data plate, which is located on the top of the door.

Steam generated from normal operation may escape from the door. Wood, laminates, veneers, etc. are unsuitable materials for use in areas exposed to dishwasher steam and detergents. Stainless steel or other moisture-resistant shields are recommended for surfaces adjacent to LXe sides and top.

LEVELING

The machine must be level to operate properly. Place the dishwasher in its operating location. Level the machine before any connections are made. Using a carpenter's level placed diagonally on the rack tracks, level the machine front to back and side to side by threading the adjustable feet in or out. After leveling the machine, cover the exposed threads of the adjustable feet with black rubber tubing supplied. (See separate instructions furnished with machine.)

WATER REQUIREMENTS

Proper water quality can improve ware washing performance by reducing spotting, enhancing effectiveness of labor and extending equipment life. Water conditions vary from one location to another. The recommended proper water treatment for effective and efficient use of this equipment will also vary depending on the local water conditions. Ask your municipal water supplier for details about your local water conditions prior to installation.

Recommended water hardness is 3 grains of hardness per gallon or less. Higher hardness may cause excessive formation of lime scale. Water hardness above 3 grains per gallon requires water treatment. Water treatment has been shown to reduce costs associated with machine cleaning, reduce deliming of the dishwasher, and reduce detergent usage in the dishwasher.

NOTICE High iron levels in the water supply can cause staining and may require an iron filter. High chloride levels in the water supply can cause pitting and may require a chloride removal system. Contact your local water treatment professional for proper water treatment.

Sediment may require a particulate filter. Dissolved solids may require water treatment such as a water softener, reverse osmosis system, etc. Contact your local water treatment professional for proper water treatment.

If an inspection of the dishwasher or booster heater reveals lime buildup after the equipment has been in service, water treatment is recommended. If a water softener is already in place, ensure there is a sufficient level of salt. Contact your local Hobart Service office for specific recommendations.

A water hammer arrestor (meeting ASSE-1010 Standard or equivalent) should be installed (supplied by others) in the common water supply line at the service connection.

The plumber connecting this machine is responsible for making certain that water lines are THOROUGHLY FLUSHED OUT BEFORE connecting to the dishwasher. This "flush-out" is necessary to remove all foreign matter, such as chips (resulting from cutting or threading of pipes) pipe joint compound from the lines; or, if soldered fittings are used, bits of solder or cuttings from the tubing. Debris, if not removed, may lodge in the dishwasher's plumbing components and render them inoperative. Manual valves or solenoid valves fouled by foreign matter and any expenses resulting from this fouling are NOT the responsibility of the manufacturer and associated repair costs are not covered under warranty.

Water supply requirements are as follows:

MODEL	TEMPERATURE
LXeC	120°F Minimum
LXePR	120°F Minimum
LXeH	110°F Minimum
LXeR	55°F Minimum, 80°F Maximum

NOTE: On LXeR installations, if cold water supply temperature is consistently above 80°F or if excessive water vapor or steam is entering the room after the condensing cycle is complete, contact Hobart Service to increase condensing time.

Required flowing water pressure to the dishmachine is 15-65 PSIG. If pressures higher than 65 PSIG are present, a pressure regulating valve must be installed in the water line to the dishmachine (by others). If flowing pressure is less than 15 psi, improper machine operation may result. All LXe models are equipped with a pumped rinse system; therefore, a water pressure gauge is not required and is not supplied with the machine.

NOTICE The water pressure regulator must have a relief bypass. Failure to use the proper type of pressure regulator may result in damage to the unit.

A manual shutoff valve (not supplied) should be installed upstream of the fill hose to accommodate servicing the machine.

It is recommended that a line strainer (not supplied) be installed in the supply line between the manual shutoff valve (not supplied) and the connection point on the machine. Make plumbing connections with ½" minimum copper piping OD (¾" recommended), with a ¾" male garden hose fitting (not supplied). See installation diagrams, pages 16-17.

PLUMBING CONNECTIONS

WARNING Plumbing connections must comply with applicable sanitary, safety, and plumbing codes.

Drain

A drain hose, 5/8" inside diameter and 6' long, is provided. This should be securely plumbed into a drain. Use care not to kink hose. See installation diagrams, pages 16-17. Drain must have a minimum flow capacity of 5 gallons per minute.

ELECTRICAL CONNECTION

⚠ WARNING Electrical and grounding connections must comply with the applicable portions of the National Electrical Code and/or other local electrical codes.

⚠ WARNING Disconnect the electrical power to the machine and follow lockout/tagout procedures.

ELECTRICAL DATA

Complied in accordance with the National Electrical Code NFPA-70, latest addition.

NOTICE For supply connections, use copper wire only rated at 90°C minimum.

Model	Volts/Hertz/Phase	Minimum Supply Circuit Conductor Ampacity	Maximum Protective Device Ampacity
LXeC LXePR	120/60/1	20	20
LXeH LXeR	208-240/60/1	40	40
	120/208-240(3W)/60/1*		
	208-240/60/3	30	30
	220-240/50/1	40	40

*The (3W) systems require three power wires that include a current carrying neutral. An additional fourth wire must be provided for machine ground.

Refer to the data plate on the door handle of the machine and the electrical label on the back side of the lower front panel for proper selection.

Connection Method

1. Remove the lower front panel by removing the two screws at the bottom of the panel (Fig. 1).



Fig. 1

2. Open door of dishwasher and remove the two left screws and the top right screw (Fig. 2). Pull top of unit forward approximately 1" and remove the left side panel.



Fig. 2

3. A hole for 1" trade size conduit is supplied at the lower right in the back of the machine (Fig. 3). If necessary due to space requirements, remove the knockout and use a 45° fitting.

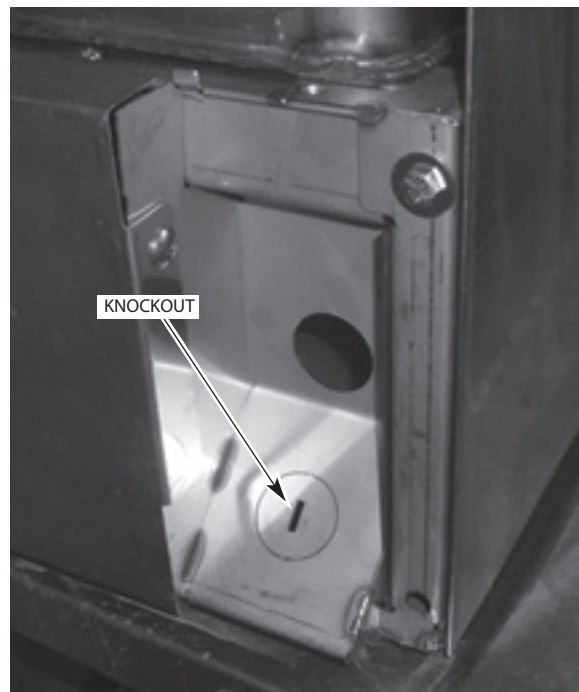

Fig. 3

4. Install 1" trade size conduit and fitting. Leave at least four feet of electrical line between wall connection and machine. This allows machine to be pulled away from the wall for cleaning and/or servicing.
5. Feed wires thru base of unit to front of unit. At least 24" and not more than 28" of the required wire size must extend from the end of the conduit fitting.
6. Make electrical connections according to wiring diagram supplied with the machine and secure wires to the machine service connection. Keep excess wire in the base of the unit to a minimum.
7. Replace the left side panel, top of unit, and lower front panel. Re-install the three screws located behind the door and the two screws at the bottom of the front panel.

DETERGENT AND RINSE AID

Use only commercial-grade detergents recommended by your chemical professional. Do not use detergents formulated for residential dishwashers.

The detergent and rinse aid pump "ON" times are factory-set. If adjustments are required, contact your local Hobart Service Office or your chemical supplier.

Place the detergent and rinse aid containers (which are obtained from an independent supplier) in a location where the delivery tubes will reach them.

Remove the detergent bottle cap and put the *red* delivery tube in the detergent container.

Remove the rinse aid bottle cap and place the *blue* delivery tube in the rinse aid container.

Be sure to push the delivery tube standpipes completely to the bottom of each container. Check to make sure there are no obstructions or kinks in the delivery tubes.

CHEMICAL SANITIZER (LXeC & LXePR)

NOTICE Items such as pewter, aluminum and silver will be attacked by sodium hypochlorite (bleach). Therefore, chemical-sanitizing dishwashers should not be used to wash such items.

On models LXeC & LXePR, the chemical sanitizer pump is factory-set for use with 6% sodium hypochlorite solution.

NOTICE If 8.40% sodium hypochlorite solution is to be used, contact your local Hobart Service Office.

On LXeC models, place a 1-gallon bottle of 6% or 8.40% sodium hypochlorite solution (bleach) in a suitable location no higher than 10 inches off the floor. Do not pre-mix sanitizing solution with water or any other liquid.

On LXePR models, place a sanitizer approved for potable water rinse machines in a suitable location no higher than 10 inches off the floor. Do not pre-mix sanitizing solution with water or any other liquid.

⚠ WARNING Never premix a wetting agent with the sanitizing solution. Mixing may cause hazardous gas to form.

Remove the sanitizer bottle cap and place the *white* delivery tube in the sanitizer container. Be sure to push the delivery tube standpipe completely to the bottom of the container. Check to make sure there are no obstructions or kinks in the delivery tube.

Frequently check your sanitizer bottle to make sure there is a sufficient chemical supply.

CHECKING SANITIZER CONCENTRATION

Verify there is sufficient chemical supply in the sanitizer bottle and that the delivery tube standpipe is inserted completely to the bottom of the chemical container. Place a glass rack, with glasses, in the machine.

On LXePR models, the PuriRinse feature must be deactivated to properly check the sanitizer concentration. To deactivate PuriRinse, press and hold the WASH key for five seconds until wash cycle starts.

On LXeC models, press the WASH key to run a cycle. At the end of the cycle, open the door.

Follow the directions precisely that are on the litmus paper vial and test the water on the surface of the bottom of the glasses. Concentration should be 50 p.p.m. minimum to 100 p.p.m. maximum.

If reading is incorrect, contact your local Hobart Service Office or chemical provider for adjustments.

DELIMING SOLUTION

All LXePR and LXeR models are equipped with an automatic deliming system. At installation, a qualified Hobart Service technician or your chemical supplier must adjust the total water hardness setting to properly set the delime intervals.

Remove the deliming agent bottle cap and put the *black* delivery tube in the container.

Be sure to push the delivery tube standpipe completely to the bottom of the container. Check to make sure there are no obstructions or kinks in the delivery tube.

PRIMING CHEMICAL PUMPS

When a chemical becomes empty, the priming operation starts automatically the next time the machine is turned on or a wash cycle is started. Note that the initial prime time for all pumps (Detergent, Rinse Agent, and Sanitizer) is 60 seconds. If the chemical is not sensed within 60 seconds, the add chemical indicator will flash. After the chemical is sensed, the indicator in the display turns off; and the pump continues to prime for 10 seconds to allow the chemicals to reach the machine. If all chemicals are empty, the sanitizer will prime first followed by detergent. Only one chemical pump will run at a time.

If chemicals are not sensed after three consecutive priming operations, the add chemical indicator will flash and priming is cancelled. The next time a wash cycle is started, the add chemical indicator will continue to flash. Verify that the chemical bottles are not empty and that the delivery tube standpipes are inserted completely to the bottom of the containers.

The priming operation can be reset by turning the dishwasher off, then back on.

If the chemical bottles are not empty and the delivery tube standpipes are inserted correctly, then the chemical sensor or pumps may have malfunctioned; contact your local Hobart Service Office.

⚠ WARNING Do not premix other chemicals and sodium hypochlorite (liquid bleach). Mixing may cause hazardous gas to form.

NOTICE Required flowing water pressure to the dishmachine is 15-65 PSIG. If pressures higher than 65 PSIG are present, a pressure regulating valve must be installed in the water line to the dishmachine (by others).

Pressure gauge not provided on pumped rinse machines.

Important: Chemical containers should be placed no higher than 10" above floor.

If chemical containers are to be placed in cabinet adjacent to machine, a 1/2" dia. hole is required in the cabinet to run chemical supply line.

Use only 6% or 8.4% sodium hypochlorite (liquid bleach) as sanitizing chemical to insure proper operation of dishmachine.

Certain materials including silver plate, aluminum and pewter are attacked by sodium hypochlorite (liquid bleach).

NOTES:

1. All vertical machine dimensions taken from floor may be increased by 1".
2. Moist air escapes from the door.
Use only moisture resistant materials adjacent to dishmachine sides and top.
3. A vent hood is not recommended above the undercounter dishmachine since it does not produce excessive vapors.

PLUMBING NOTES:

1. Water hammer arrestor (meeting ASSE-1010 standard or equivalent) to be supplied (by others) in common water supply line at service connection.
2. Recommended water hardness to be 3 grains or less for best results.
3. If drain hose is looped above a sink, the loop must not exceed 38" AFF.

CONNECTION INFORMATION
(AFF = ABOVE FINISHED FLOOR)

LEGEND

- E1 ELECTRICAL CONNECTION: 1-3/8" DIA. HOLE FOR 1" TRADE SIZE CONDUIT; 4-5/8" AFF.
- P1 SINGLE FILL AND RINSE CONNECTION: 3/4" FEMALE GARDEN HOSE FITTING ON 6' LONG HOSE SUPPLIED WITH MACHINE; 120°F WATER MIN. FOR LXeC, 140°F RECOMMENDED.
- P2 DRAIN CONNECTION: 5/8" BARB FITTING WITH 6' LONG HOSE SUPPLIED WITH MACHINE.

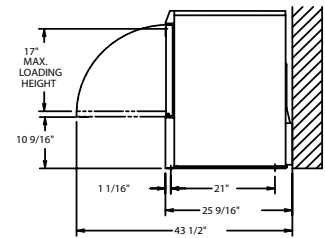
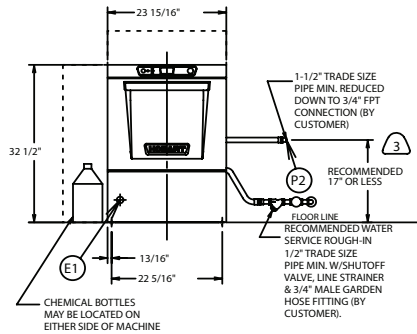
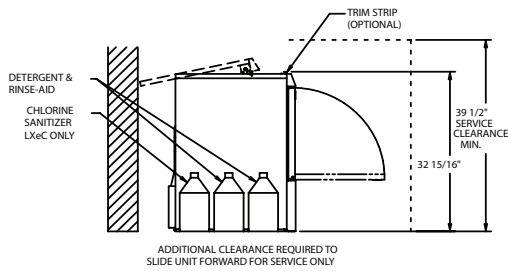
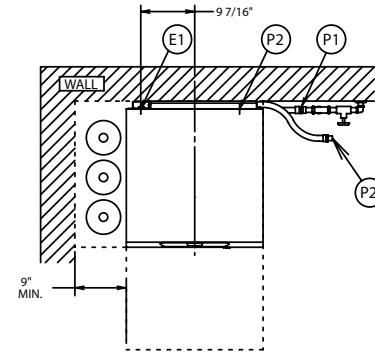

MODEL	VOLTS/HERTZ/PHASE	RATED AMPS	MIN SUPPLY CKT CONDUCT AMPACITY	MAX PROTECTIVE DEVICES
LXeC	120/60/1	13.4	20	20

HEAT OUTPUT, BTU/HR		
MODEL	LATENT	SENSIBLE
LXeC	1900	800

SHIPPING WEIGHTS	LXeC
NET WEIGHT OF MACHINE	150 LBS
DOMESTIC SHIPPING WEIGHT	170 LBS

ACCESSORY CORD KITS AVAILABLE FOR ALL MACHINES

NOTE: FOR SUPPLY CONNECTIONS, USE COPPER WIRE ONLY RATED AT 90°C MINIMUM.

⚠ WARNING Electrical and grounding connections must comply with the applicable portions of the National Electrical Code and/or other local electrical codes.

Plumbing connections must comply with applicable sanitary, safety and plumbing codes. Drain and fill line configurations vary, some methods are shown on this drawing.

INSTALLATION DIAGRAM (LXeC)

NOTICE Required flowing water pressure to the dishmachine is 15-65 PSIG. If pressures higher than 65 PSIG are present, a pressure regulating valve must be installed in the water line to the dishmachine (by others).

Pressure gauge not provided on pumped rinse machines.

Important: The chemical containers should be placed no higher than 10" above floor.

If chemical containers are to be placed in cabinet adjacent to machine, a 1/2" dia. hole is required in the cabinet to run chemical supply line.

NOTES:

1. All vertical machine dimensions taken from floor may be increased by 1".
2. Moist air escapes from the door.
Use only moisture resistant materials adjacent to dishmachine sides and top.
3. A vent hood is not recommended above the undercounter dishmachine since it does not produce excessive vapors.

PLUMBING NOTES:

1. Water hammer arrestor (meeting ASSE-1010 standard or equivalent) to be supplied (by others) in common water supply line at service connection.
2. Recommended water hardness to be 3 grains or less for best results.
3. If drain hose is looped above a sink, the loop must not exceed 38" AFF.

**CONNECTION INFORMATION
(AFF = ABOVE FINISHED FLOOR)**

LEGEND

- E1 ELECTRICAL CONNECTION: 1-3/8" DIA. HOLE FOR 1" TRADE SIZE CONDUIT; 4-5/8" AFF.
- P1 SINGLE FILL AND RINSE CONNECTION: 3/4" FEMALE GARDEN HOSE FITTING ON 6' LONG HOSE SUPPLIED WITH MACHINE; 110°F WATER MIN. FOR LXeH.
- P2 DRAIN CONNECTION: 5/8" BARB FITTING WITH 6' LONG HOSE SUPPLIED WITH MACHINE.

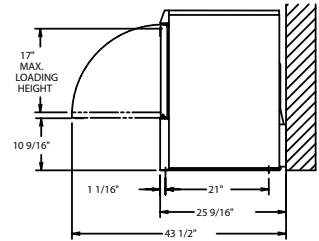
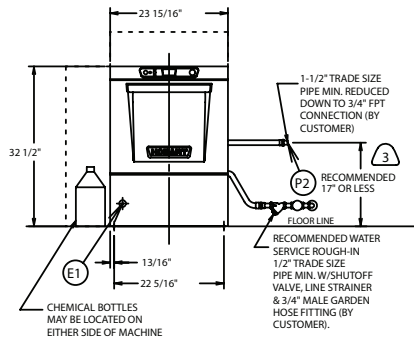
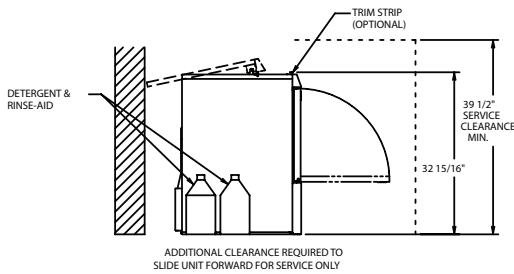
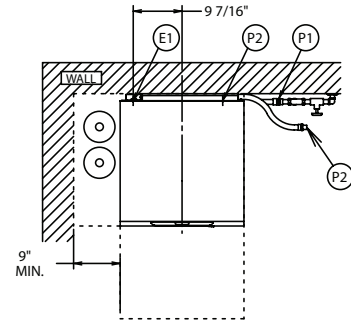

MODEL	VOLTS/HERTZ/PHASE	RATED AMPS	MIN SUPPLY CKT CONDUCT AMPACITY	MAX PROTECTIVE DEVICES
LXeH	208-240/60/1	30.5	40	40
	120/208-240(3W)/60/1*	30.5	40	40
	208-240/60/3	23.9	30	30
	220-240/50/1	30.5	40	40

HEAT OUTPUT, BTU/HR		
MODEL	LATENT	SENSIBLE
LXeH	4600	4000

SHIPPING WEIGHTS	LXeH
NET WEIGHT OF MACHINE	150 LBS
DOMESTIC SHIPPING WEIGHT	170 LBS

* THIS SYSTEM REQUIRES THREE POWER WIRES WHICH INCLUDES A CURRENT CARRYING NEUTRAL, AN ADDITIONAL FOURTH WIRE MUST BE PROVIDED FOR MACHINE GROUND.

ACCESSORY CORD KITS AVAILABLE FOR ALL MACHINES

NOTE: FOR SUPPLY CONNECTIONS, USE COPPER WIRE ONLY RATED AT 90°C MINIMUM.

WARNING Electrical and grounding connections must comply with the applicable portions of the National Electrical Code and/or other local electrical codes.

Plumbing connections must comply with applicable sanitary, safety and plumbing codes. Drain and fill line configurations vary, some methods are shown on this drawing.

INSTALLATION DIAGRAM (LXeH)

⚠ WARNING Do not pre-mix other chemicals and sodium hypochlorite (liquid bleach). Mixing may cause hazardous gas to form.

NOTICE Required flowing water pressure to the dishmachine is 15-65 PSIG. If pressures higher than 65 PSIG are present, a pressure regulating valve must be installed in the water line to the dishmachine (by others).

Pressure gauge not provided on pumped rinse machines.

Important: The chemical containers should be placed no higher than 10" above floor. If chemical containers are to be placed in cabinet adjacent to machine, a 1/2" dia. hole is required in the cabinet to run chemical supply line. Use only 6% or 8.4% sodium hypochlorite (liquid bleach) as sanitizing chemical to insure proper operation of dishmachine. Certain materials including silver plate, aluminum and pewter are attacked by sodium hypochlorite (liquid bleach).

- NOTES:**
- All vertical machine dimensions taken from floor may be increased by 1".
 - Moist air escapes from the door. Use only moisture resistant materials adjacent to dishmachine sides and top.
 - A vent hood is not recommended above the undercounter dishmachine since it does not produce excessive vapors.

- PLUMBING NOTES:**
- Water hammer arrestor (meeting ASSE-1010 standard or equivalent) to be supplied (by others) in common water supply line at service connection.
 - Recommended water hardness to be 3 grains or less for best results.
 - If drain hose is looped above a sink, the loop must not exceed 38" AFF.

CONNECTION INFORMATION
(AFF = ABOVE FINISHED FLOOR)

LEGEND

- E1 ELECTRICAL CONNECTION: 1-3/8" DIA. HOLE FOR 1" TRADE SIZE CONDUIT; 4-5/8" AFF.
- P1 SINGLE FILL AND RINSE CONNECTION: 3/4" FEMALE GARDEN HOSE FITTING ON 6' LONG HOSE SUPPLIED WITH MACHINE; 120°F WATER MIN. FOR LXePR, 140°F RECOMMENDED.
- P2 DRAIN CONNECTION: 5/8" BARB FITTING WITH 6' LONG HOSE SUPPLIED WITH MACHINE.

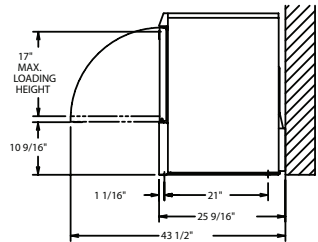
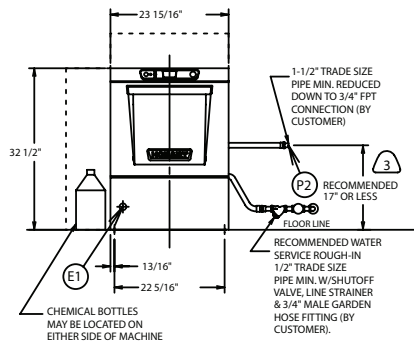
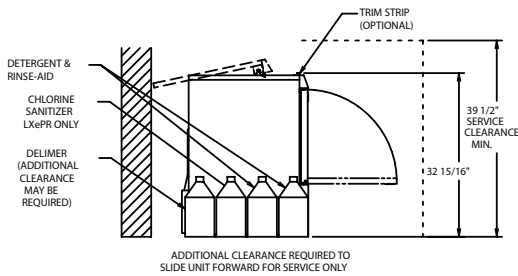
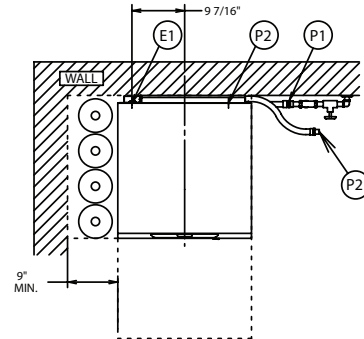

MODEL	VOLTS/HERTZ/PHASE	RATED AMPS	MIN SUPPLY CKT CONDUCT AMPACITY	MAX PROTECTIVE DEVICES
LXePR	120/60/1	13.4	20	20

HEAT OUTPUT, BTU/HR		
MODEL	LATENT	SENSIBLE
LXePR	1900	800

SHIPPING WEIGHTS	LXePR
NET WEIGHT OF MACHINE	150 LBS
DOMESTIC SHIPPING WEIGHT	170 LBS

ACCESSORY CORD KITS AVAILABLE FOR ALL MACHINES

NOTE: FOR SUPPLY CONNECTIONS, USE COPPER WIRE ONLY RATED AT 90°C MINIMUM.

⚠ WARNING Electrical and grounding connections must comply with the applicable portions of the National Electrical Code and/or other local electrical codes.

Plumbing connections must comply with applicable sanitary, safety and plumbing codes. Drain and fill line configurations vary, some methods are shown on this drawing.

INSTALLATION DIAGRAM (LXePR)

NOTICE Required flowing water pressure to the dishmachine is 15-65 PSIG. If pressures higher than 65 PSIG are present, a pressure regulating valve must be installed in the water line to the dishmachine (by others).

Pressure gauge not provided on pumped rinse machines.

If chemical containers are to be placed in cabinet adjacent to machine, a 1/2" dia. hole is required in the cabinet to run chemical supply line.

NOTES:

1. All vertical machine dimensions taken from floor may be increased by 1".
2. Moist air escapes from the door.
3. A vent hood is not recommended above the undercounter dishmachine since it does not produce excessive vapors.

PLUMBING NOTES:

1. Water hammer arrestor (meeting ASSE-1010 standard or equivalent) to be supplied (by others) in common water supply line at service connection.
2. Recommended water hardness to be 3 grains or less for best results.
3. If drain hose is looped above a sink, the loop must not exceed 38" AFF.

**CONNECTION INFORMATION
(AFF = ABOVE FINISHED FLOOR)**

LEGEND

- E1 ELECTRICAL CONNECTION: 1-3/8" DIA. HOLE FOR 1" TRADE SIZE CONDUIT; 4-5/8" AFF.
- P1 SINGLE FILL AND RINSE CONNECTION: 3/4" FEMALE GARDEN HOSE FITTING ON 6' LONG HOSE SUPPLIED WITH MACHINE; 55-80°F (COLD) RECOMMENDED FOR LXeR.
- P2 DRAIN CONNECTION: 5/8" BARB FITTING WITH 6' LONG HOSE SUPPLIED WITH MACHINE.

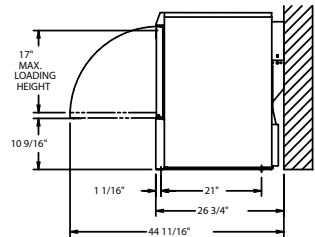
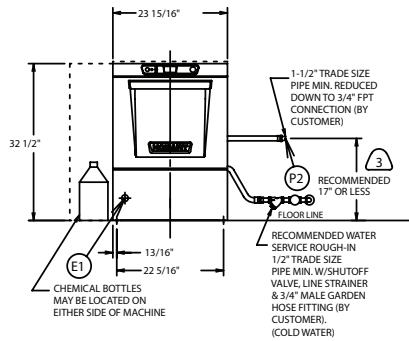
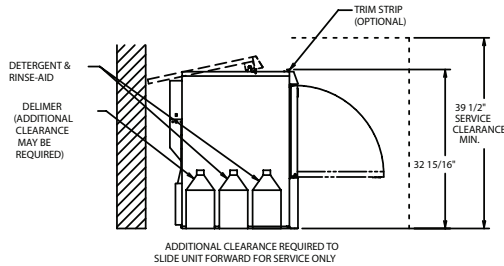
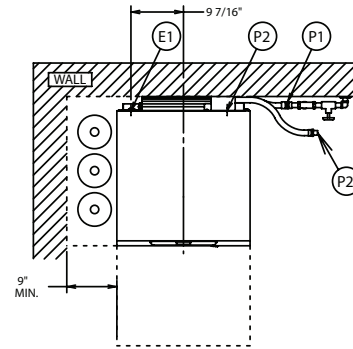

MODEL	VOLTS/HERTZ/PHASE	RATED AMPS	MIN SUPPLY CKT CONDUCT AMPACITY	MAX PROTECTIVE DEVICES
LXeR	208-240/60/1	30.5	40	40
	120/208-240(3W)/60/1*	30.5	40	40
	208-240/60/3	23.9	30	30
	220-240/50/1	30.5	40	40

HEAT OUTPUT, BTU/HR		
MODEL	LATENT	SENSIBLE
LXeR	1100	2000

SHIPPING WEIGHTS	
NET WEIGHT OF MACHINE	LXeR 165 LBS
DOMESTIC SHIPPING WEIGHT	185 LBS

* THIS SYSTEM REQUIRES THREE POWER WIRES WHICH INCLUDES A CURRENT CARRYING NEUTRAL, AN ADDITIONAL FOURTH WIRE MUST BE PROVIDED FOR MACHINE GROUND.

ACCESSORY CORD KITS AVAILABLE FOR ALL MACHINES

NOTE: FOR SUPPLY CONNECTIONS, USE COPPER WIRE ONLY RATED AT 90°C MINIMUM.

WARNING Electrical and grounding connections must comply with the applicable portions of the National Electrical Code and/or other local electrical codes.

Plumbing connections must comply with applicable sanitary, safety and plumbing codes. Drain and fill line configurations vary, some methods are shown on this drawing.

INSTALLATION DIAGRAM (LXeR)

PROGRAMMING

MANAGER MODE PROGRAMMING

The LXe series warewasher's microprocessor allows customization options for machine operation. To activate or change these features, the programming edit mode must be entered.

The manager programming mode requires a MANAGER CODE to be entered to access the options listed in the PARAMETERS MENU. The manager code is 1001.

PROGRAMMING INSTRUCTIONS

All customization is performed through the on-screen menu using the UP Arrow, MENU/DOWN Arrow, and the ENT keys located on the keypad at the top of the machine (Fig. 4).

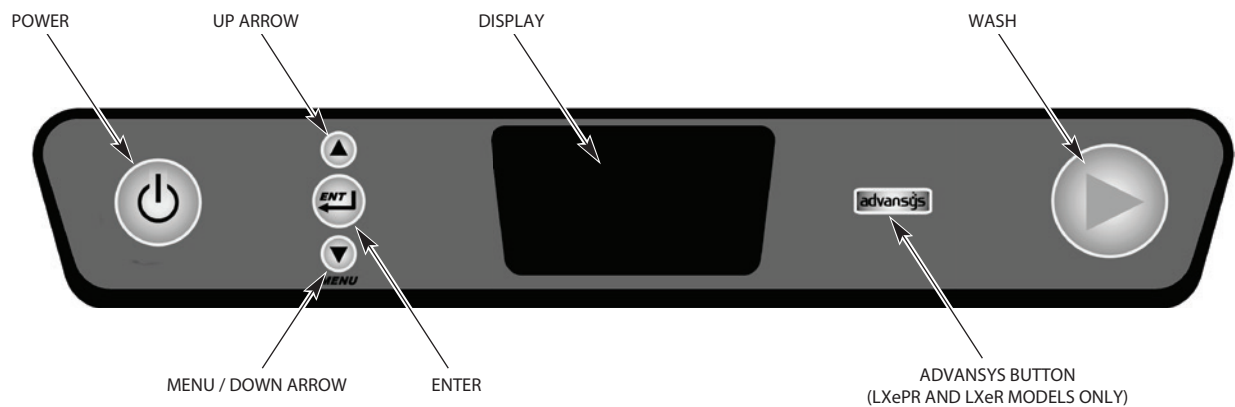

Fig. 4

MENU DISPLAY PROMPTS

The following prompts are used inside the menus:

- The UP arrow and MENU/DOWN arrow keys are used to change parameter values and to navigate the menu.
- The ENT key is used to accept a value, to perform a specified action, or to enter a submenu.
- The text just to the right of the '>' symbol on the display screen shows what action or command will occur if the ENT key is pressed.



Manager Mode Programming Card

CHANGING PARAMETERS ENTER MANAGER SECURITY CODE: 1001



CHANGING PARAMETERS IS REQUIRED TO CHANGE ALL CODES BELOW

CHEMICAL PUMP enable or disable the detergent pump or rinse aid pump.



LOW TEMP ALARMS for hot machines only: enables or disables alert indicating that the final rinse temperature has been below the minimum temperature for a period of time.

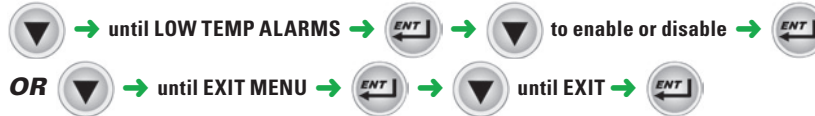

DELIME enables or disables the delime reminder alert.

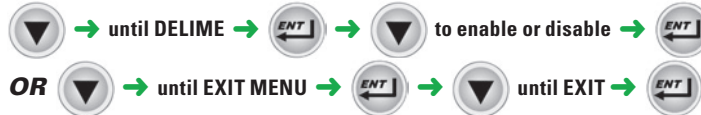

TEMPERATURE UNITS allows the choice of Fahrenheit or Celsius.

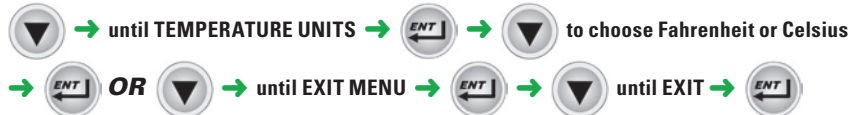

ADD CHEMICAL ALERT enable or disable the audio alert of missing chemicals.

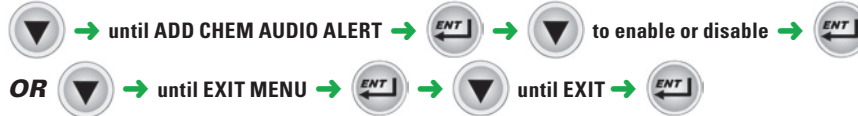

END CYCLE AUDIO ALERT enable or disable the unit creating an audio alert at the end of each wash cycle.

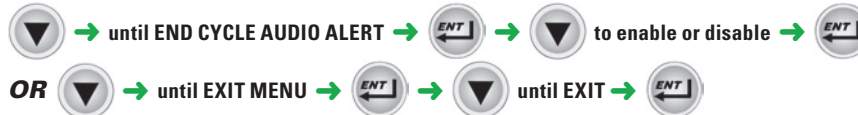

LANGUAGE allows the choice of English or French language.

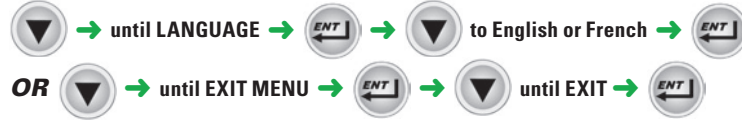

EXIT MENU TO MAIN MANAGER MENU



DELIME NOW allows for a single delime cycle to be run from the menu at anytime.
Note: this operation takes 20-45 minutes depending on conditions.





Manager Mode Programming Card

CHANGING PARAMETERS ENTER MANAGER SECURITY CODE: 1001



CHANGING PARAMETERS IS REQUIRED TO CHANGE ALL CODES BELOW

CHEMICAL PUMP enable or disable the detergent pump or rinse aid pump.



WASH CYCLE allows the customization of total run time.



LOW TEMP ALARMS for hot machines only: (parameter) enables or disables alert indicating that the final rinse temperature has been below the minimum temperature for a period of time.

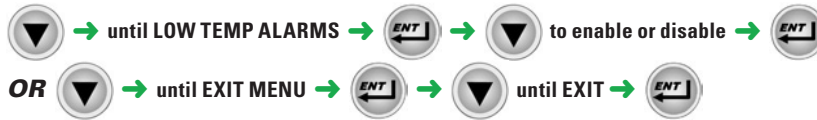

WASH ARM ALARM enables or disables an alarm that alerts the operator that the wash arms may be clogged or blocked.

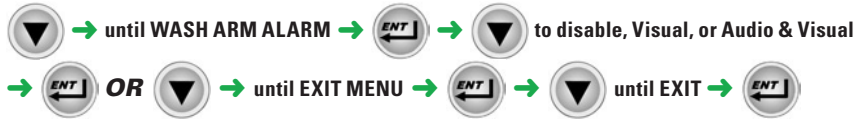

DELIME enables or disables the delime reminder alert.

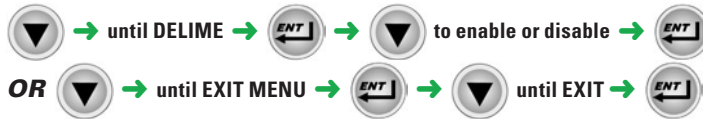

TEMPERATURE UNITS allows the choice of Fahrenheit or Celsius.

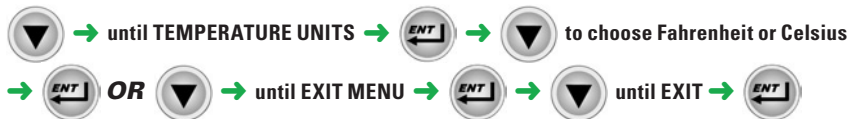

POTABLE RINSE for cold machines only enables or disables the potable water rinse option.

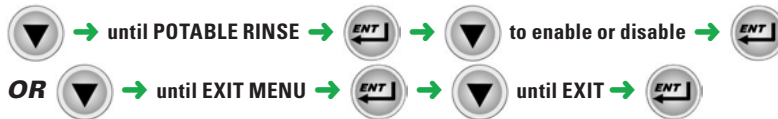

DIRTY WATER INDICATOR disables or gives a choice of how many cycles the machine will run between dirty water alert and refresh cycles.

▼ → until DIRTY WATER INDICATOR → ENT → ▼ to Disable, 20 cycles, 40 cycles, or 60 cycles → ENT OR ▼ → until EXIT MENU → ENT → ▼ until EXIT → ENT

ENERGY SAVER MODE disables or gives choice of how many hours before the unit will stay on before entering energy saving mode.

▼ → until ENERGY SAVING MODE → ENT → ▼ to Disabled, 1 Hour, 2 Hours, or 3 Hours → ENT OR ▼ → until EXIT MENU → ENT → ▼ until EXIT → ENT

ADD CHEMICAL ALERT enable or disable the audio alert of missing chemicals.

▼ → until ADD CHEM AUDIO ALERT → ENT → ▼ to enable or disable → ENT OR ▼ → until EXIT MENU → ENT → ▼ until EXIT → ENT

END CYCLE AUDIO ALERT enable or disable the unit creating an audio alert at the end of each wash cycle.

▼ → until END CYCLE AUDIO ALERT → ENT → ▼ to enable or disable → ENT OR ▼ → until EXIT MENU → ENT → ▼ until EXIT → ENT

LANGUAGE allows the choice of English or French language.

▼ → until LANGUAGE → ENT → ▼ to English or French → ENT OR ▼ → until EXIT MENU → ENT → ▼ until EXIT → ENT

advansys BUTTON allows the customization of the **advansys** button to be used for a variety of options.

▼ → until **advansys** BUTTON → ENT → ▼ to: Clean Sump, One Light Wash, One Normal Wash, One Heavy Wash, Run Delime Cycle, or Energy Saver → ENT OR ▼ → until EXIT MENU → ENT → ▼ until EXIT → ENT

EXIT MENU TO MAIN MANAGER MENU

→ ▼ until EXIT MENU → ENT

DELIME NOW allows for a single delime cycle to be run from the menu at anytime.

Note: this operation takes 20-45 minutes depending on conditions.

▼ → until DELIME NOW → ENT → ▼ to YES or NO → ENT (this will exit menu)

PARAMETERS MENU TABLE

Parameter Name	Base Models (LXeC, LXeH)	Advansys Models (LXePR, LXeR)	Description	Possible Values	Default Value
Detergent Pump	✓	✓	Enables or disables the detergent pump.	Disabled or Enabled	Enabled
Rinse Aid Pump	✓	✓	Enables or disables the rinse aid pump.	Disabled or Enabled	Enabled
Wash Cycle		✓	Sets the cycle duration.	Light, Normal, or Heavy	Normal
Low Temp Alarms	LXeH Only	LXeR Only	Enables or disables a visual alert on the display that indicates that the Final Rinse water temperature is below the required minimum of 180°F (82°C). When enabled, a message will display notifying the user of this condition after three consecutive cycles do not reach the required final rinse temperature. However, machine operation will not change and ware will continue to wash as expected. After the temperature increases past the minimum, the message stops. When disabled, there will be no extra message indicating a low temperature event; however, the temperature display will still show the current Final Rinse water temperature.	Disabled or Enabled	Disabled
Wash Arm Alert		✓	Enables Visual Alert, Audio and Visual Alert, or disables an alert that is displayed when the machine detects a wash arm that is clogged or blocked such that ware wash results could be affected.	Disabled, Visual, or Audio and Visual	Audio and Visual
Delime	✓	✓	Enables or disables the alert to delime option.	Disabled or Enabled	Enabled
Temperature Units	✓	✓	Sets the display units to either Fahrenheit or Celcius.	Fahrenheit or Celcius	Fahrenheit
Potable Rinse		LXePR Only	On LXePR machines, this setting enables or disables the PuriRinse option that sprays fresh water after the sanitization cycle to remove the sanitizer from the ware.	Disabled or Enabled	Enabled

Parameter Name	Base Models (LXeC, LXeH)	Advansys Models (LXePR, LXeR)	Description	Possible Values	Default Value
Dirty Water Indicator		✓	On Advansys machines, this setting allows for a reminder for the operator to be notified that 20, 40, or 60 cycles have passed and a special water refresh cycle is recommended. This cycle will drain a portion of the wash water and refresh it with fresh hot water.	Disabled, 20, 40, or 60 cycles	40 Cycles
Energy Saver Mode		✓	On Advansys machines, this setting will control when the machine will turn the heaters off in order to save energy when not in use.	Disabled, 1, 2, or 3 hours	2 hours
Add Chemical Alert	✓	✓	Enables or disables an audible alert if chemical is not being detected.	Disabled, Visual, or Audio and Visual	Audio and Visual
End Cycle Audio Alert	✓	✓	Enables or disables an audible alert at the end of a cycle.	Disabled or Enabled	Disabled
Language	✓	✓	Sets the language on the display to either English or French.	English (US) or French (Canada)	English (US)
Advansys Button		✓	Choose function for Advansys button.	<ol style="list-style-type: none"> 1. Not programmed 2. Clean the sump 3. One light wash 4. One normal wash 5. One heavy wash 6. Run delime cycle 7. Energy saver 	Not Programmed From Factory
Exit Menu	✓	✓	Press ENT to exit the Parameters Menu and return to the Manager Menu. Any settings that were changed are saved.		

OPERATION

NOTICE Items such as pewter, aluminum and silver will be attacked by sodium hypochlorite (bleach). Therefore, chemical-sanitizing dishwashers should not be used to wash such items.

If your dishwasher is a chemical-sanitizing model, frequently check the sanitizer bottle to make sure there is a sufficient chemical supply.

BEFORE FIRST USE

This machine must be cleaned after installation and before being put into operation. (See Cleaning.)

CONTROLS



LXeC and LXeH
Fig. 5











LXePR and LXeR
Fig. 6

OPERATING THE LXe DISHWASHER

DO THIS	DISPLAY SHOWS	REMARKS
Press ON.	Model number.	Dishwasher performs self-check. This takes 5 seconds.
	FILL and fill icon lit; sump temperature displayed when machine is filling. WARMING UP and warming up icon are displayed when booster is preheating on models LXeH and LXeR. This preheat could take up to 15 minutes.	Dishwasher fills with water. When filled, pump turns on for 10 seconds. If door is opened during fill cycle, fill will stop. After door is closed, the process continues where it stopped.
	During fill, sump temperature is displayed.	When filled, machine will maintain an idle state. Heat is maintained in both sump and/or booster.
Open door; slide rack of dishes into dishwasher. Close door.	READY lit and sump temperature displayed.	Detergent will be added automatically during wash cycle. Rinse Aid and Sanitizer will be added automatically during rinse cycle. (NOTE: Sanitizer only used on LXeC and LXePR models.)
Press WASH.	WASH and wash icon lit; sump temperature displayed during wash cycle.	Machine initiates a wash and rinse cycle.
	RINSE and rinse icon lit; rinse temperature displayed during rinse cycle.	If door is opened during wash, rinse, or drain cycle, cycle will continue at point where door was opened upon closing door. If POWER is pressed during cycle, machine will drain and shut down.
When cycle is complete, reload machine for next wash/rinse cycle; or, if not in use, machine will maintain idle mode.	READY lit and sump temperature displayed.	Machine will drain and shut down if the four hour idle shutdown time is reached.
At the end of the day, press POWER.	DRAIN and SHUTDOWN IN PROGRESS are displayed; then the display shuts down.	When POWER key is pressed, machine will drain and shut down.

DIAGNOSTIC/ERROR MESSAGES

Error	Display		Description
Door Open	Door Open		Displayed when the door of the machine is opened.
Clogged/ Blocked Wash Arm	WASH ARM ALERT - Remove & clean arm - Check nozzles - Replace arm - Close door		Displayed if wash arm is blocked or clogged which would result in poor wash results. Follow on-screen instructions.
Low Rinse Temperature	LOW RINSE TEMP		After two consecutive low temperatures, if problem occurs on the third consecutive cycle, the error will display. The machine will continue to run cycles.
Low Rinse Temperature (10 In A Row)	LOW RINSE TEMP Check Water Input		If the Low Rinse Temperature error occurs for 10 consecutive cycles, the error will change. The machine will continue to run cycles.
Wash Thermistor Error	WASH TEMP SENSOR Service Required (Service Phone Number) OPEN or SHORT		Error displayed if wash temperature probe is out of range. The machine will continue to run cycles.
Booster Thermistor Error	BOOSTER TEMP SENSOR Service Required (Service Phone Number) OPEN or SHORT		Error displayed if booster temperature probe is out of range. The machine will continue to run cycles. (LXeH & LXeR models only.)
Final Rinse Thermistor Error	RINSE TEMP SENSOR Service Required (Service Phone Number) OPEN or SHORT		Error displayed if final rinse temperature probe is out of range. The machine will continue to run cycles.
Low Water In Booster (Time Out Within Any Cycle)	FILL ERROR Service Required (Service Phone Number)		Error displayed if the unit times out before the unit is completely filled. The machine will not operate and will only allow power down.
Drain Error	DRAIN ERROR Service Required (Service Phone Number)		Error displayed if the water level in the unit will not come up. The machine will not operate and will only allow power down.
Sump Level Error	SUMP LEVEL SENSOR Service Required (Service Phone Number) OPEN or SHORT		Error displayed if sump pressure switch is out of range. The machine will not operate and will only allow power down.
Booster Level Error	BOOSTER LEVEL SENSOR Service Required (Service Phone Number) OPEN or SHORT		Error displayed if booster pressure switch is out of range. The machine will not operate and will only allow power down.

WASH/RINSE CYCLE TIMES (LXeC)

Wash 85 Seconds
Drain 18 Seconds Max
Rinse 10 Seconds

WASH/RINSE CYCLE TIMES (LXeH)

Wash 85 Seconds*
Drain 18 Seconds Max
Rinse 10 Seconds
Dwell 5 Seconds

* Maximum wash time may vary, depending on operation voltage and incoming water temperature for 70°F rise on LXeH machines.

WASH/RINSE CYCLE TIMES (LXePR)

Wash 85 Seconds **
Drain 18 Seconds Max
Rinse 8 Seconds
Dwell 10 Seconds
PuriRinse 7 Seconds

WASH/RINSE CYCLE TIMES (LXeR)

Wash 85 Seconds *, **
Drain 18 Seconds Max
Rinse 8 Seconds
Dwell 5 Seconds
Condense 105 Seconds Max

* Maximum wash time may vary, depending on operation voltage and incoming water temperature for 70°F rise on LXeR machines.

** Wash cycle time can be adjusted to a 56, 85, or 215 second cycle.

PREPARATION

Make sure the coarse (Fig. 7) and fine (Fig. 8) strainers are in place and free of debris. Ensure that the coarse strainer is installed with the handle towards the front of the machine. Check both wash arms and rinse arms to make sure they spin freely and are not clogged.



Fig. 7



Fig. 8

Dishes must be scraped and/or rinsed to remove food particles and other debris. Never use steel wool on ware to be loaded into the dishwasher. Place dishes in a rack. Do not stack dishes on top of each other as water must have free access to all sides of every dish. Stand plates edgewise in a peg-type rack (Fig. 9). Cups, glasses and bowls should lay upside down in an open or compartment-type rack (Fig. 9). Silverware and other small pieces should lay loosely on the bottom of a flat-bottom rack. Do not allow foreign objects to enter the unit, especially metallic contaminants such as staples and paper clips.

Check to see if any detergent, rinse aid or sanitizer chemicals need to be replenished. Use only commercial-type detergents, as prescribed by your chemical professional.

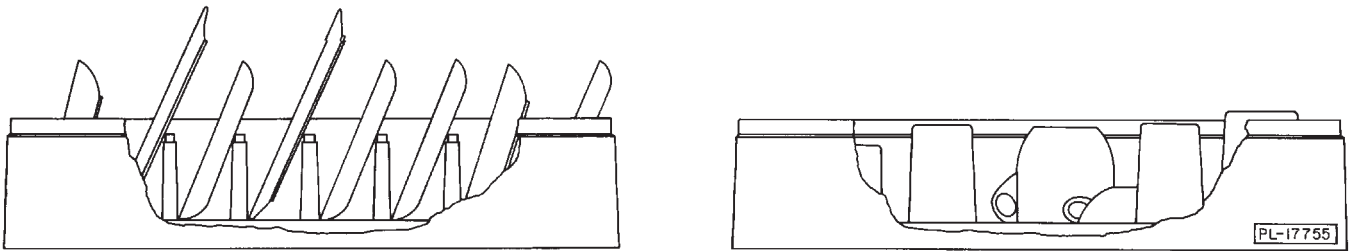

Fig. 9

DO'S AND DON'TS FOR YOUR NEW HOBART DISHWASHER

DO assure proper water hardness.

DO prescrape dishes thoroughly.

DO use only detergents recommended by your chemical professional.

DO, at the end of the day, thoroughly clean the machine, rinse and dry. (Leave door open.)

DO use only products formulated to be safe on stainless steel.

DO NOT use detergents formulated for residential dishwashers.

DO NOT allow food soil to accumulate on the tank bottom.

DO NOT exceed chemical manufacturer's recommended concentrations for detergent, sanitizer, rinse aid or lime scale remover.

DO NOT use steel wool to clean ware or warewasher surface.

DO NOT allow foreign objects to enter the unit, especially metallic contaminants.

CLEANING

This machine must be cleaned at least once each working day. Use only products formulated to be safe on stainless steel.

1. Press POWER. The machine will drain. When the display is no longer lit, open the door and remove any debris from the bottom of the tank. Do not allow food soil to accumulate on the tank bottom.
2. On LXeC and LXeH models, remove the lower rinse arm by unscrewing the thumb nut (Fig. 10). On LXePR and LXeR models, remove the lower rinse arm by pressing in on the buttons located on the sides of the center hub and pull off (Fig. 11). Remove the lower wash arm by pulling the arm off the shaft. Remove the upper rinse and wash arms in the same manner. Remove the coarse and fine strainers (see Figs. 7 and 8). Thoroughly clean these items in a sink. Remove debris from wash/rinse arm nozzles.

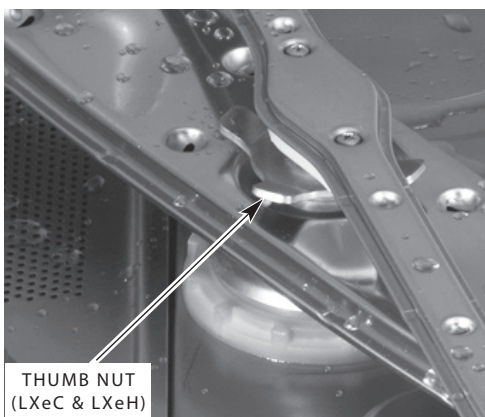

Fig. 10

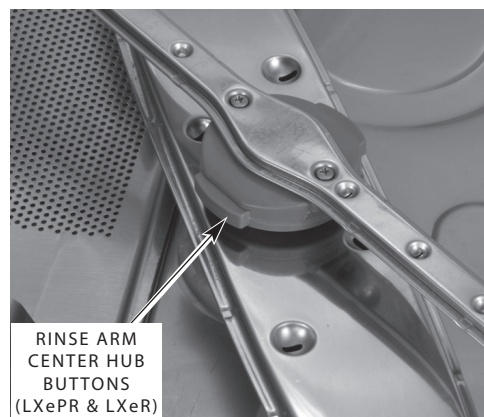

Fig. 11

3. With a damp cloth, wipe the interior of the machine. DO NOT use steel wool. Wipe the exterior of the machine. Remove any remaining debris with a mild cleanser formulated for stainless steel and a soft cloth or brush.
4. Replace the fine and coarse strainers. Reinstall the lower wash arm by pushing it down on the shaft. On LXeC and LXeH models, place the lower rinse arm on the shaft and securely tighten the thumb nut. On LXePR and LXeR models, press in on the buttons located on the sides of the center hub, place the rinse arm on the shaft, and release. Spin arms to make sure they spin freely. Repeat this procedure with the upper wash and rinse arms.
5. Use a soft, damp cloth or sponge and mild cleanser to clean the control keypad and display. DO NOT use abrasive or harsh cleaners or scouring pads.
6. Leave the door ajar overnight to allow the interior to air out and dry. The door design allows for the door to remain partially open and can be used to vent the machine at the end of the day.

MAINTENANCE

Maintenance and regular care is important to maintain optimal results with your Hobart warewasher.

DELIMING

⚠ WARNING Deliming solution, rinse agents or any other kind of acid must not come in contact with bleach or rinse solution containing bleach used in chemical-sanitizing machines. Mixing may cause hazardous gas to form. This entire procedure must be followed step by step for safe and satisfactory results.

NOTICE Do not allow the deliming agent to remain in the machine longer than recommended by the deliming agent manufacturer.

DELIME THE DISHWASHER ON A REGULAR BASIS AS REQUIRED. The regularity will depend on mineral content of the supply water. Deliming should be done when you can see clear signs of lime deposits (a white, chalky substance) on the inside walls and on the wash arms. All LXe models are equipped with an automatic delime cycle reminder. It is recommended that deliming be done when DELIME RECOMMENDED is lit. LXePR and LXeR models are equipped with an internal delime pump which will automatically pump the required amount of deliming agent into the unit.

If deliming is necessary, a deliming agent (such as Lime-A-Way[®] or LSR[®]) should be used for best results.

After the preprogrammed number of cycles has expired, the control will indicate the delime request by displaying DELIME RECOMMENDED and will prompt 'Would you like to delime now?'. You must enter 'Yes' or 'No' to proceed with a delime cycle or to continue with normal machine operation. If 'No' is selected, the machine will continue to notify the operator at each start-up and power down until the delime cycle is completed. To delime the unit:

1. Press the MENU/DOWN Arrow key until the '>' symbol is shown to the left of 'Yes' and press the ENT key.
2. Remove dish rack from machine.
3. Remove strainers from machine and clean. Replace strainers and close door.
4. On LXePR and LXeR models, ensure delimer chemical container is not empty. Be sure to push the delivery tube standpipe completely to the bottom of the container. Check to make sure there are no obstructions or kinks in the delivery tube.
5. Press ENT key to enter the delime mode. The machine will drain and refill with fresh water.
6. On LXeC and LXeH models, the display will prompt 'ADD DELIME AGENT' once the fill cycle has completed. Open the door and add deliming agent. (Carefully follow supplier's instructions.) The sump holds approximately 3 gallons of water. On LXePR and LXeR models, the unit will automatically pump in the required amount of deliming agent during the fill cycle.
7. On LXeC and LXeH models, after the deliming agent has been added, close the door. Press the ENT key to continue the cycle. The machine will enter the wash mode for 10 minutes, then will begin two rinse and drain operations. On LXePR and LXeR models, the unit will automatically enter the wash mode for 10 minutes, then will begin two rinse and drain operations after the fill cycle is complete.
8. After the deliming operation is completed, power to the control will be turned off.
9. Inspect the interior of the machine for lime deposits. If necessary, another delime cycle can be initiated by entering the Manager Programming Mode.

LUBRICATION

The pump motor has permanently sealed bearings and requires no lubrication.

TROUBLESHOOTING

This section outlines various symptoms and possible causes that may be encountered in the event of abnormal machine operation. If symptoms persist after possible causes have been checked, service may be required.

Symptom	Possible Causes
No machine operation (no display).	<ol style="list-style-type: none"> 1. Machine OFF - turn machine ON. 2. Blown fuse or circuit breaker off at power supply. 3. Cord not plugged in (corded models only)
No machine operation (with display).	<ol style="list-style-type: none"> 1. Display: "DOOR OPEN" - open and close door. If problem persists, contact your local Hobart Service Office. 2. See "Machine will not fill or will not fill high enough".
Dishes not clean.	<ol style="list-style-type: none"> 1. Strainers clogged causing inadequate water supply to pump - clean according to instructions. (See CLEANING.) 2. Obstruction in wash arm(s) or wash arms will not turn - clean according to instructions. (See CLEANING.) 3. Wash and/or rinse arms will not turn - check that they spin freely. 4. Detergent dispenser may be clogged. 5. Soil quantity - scrape dishes before cycle. 6. Improper rack loading. (See PREPARATION.) 7. Low water - check water supply. 8. Water temperature too low - note wash temperature on display during WASH; should be above 120°F for chemical sanitizing machines and above 150°F for high temperature machines. 9. Incoming water supply turned off.
Spotting of silverware, glasses, or dishes.	<ol style="list-style-type: none"> 1. Improperly loaded racks. 2. Water temperature too low. 3. Improper type or concentration of detergent - contact your chemical representative. 4. Hard water - install a water softener; use a rinse agent. 5. Insufficient fill - check water supply.
Chemicals not feeding.	<ol style="list-style-type: none"> 1. Low on chemicals - check levels. 2. Air leak at feeder hose connections - check insertion of quick connect fittings and wire ties at tube to tube connections. 3. Tubes kinked - check for smooth bends.
Food soils remain in dishwasher.	Follow daily cleaning instructions. (See CLEANING.)
Appearance of rust in machine.	<ol style="list-style-type: none"> 1. Ensure steel wool is not used to clean machine. 2. May be due to high iron content in water supply.

Symptom	Possible Causes
Unexpected results on dishes.	<ol style="list-style-type: none"> 1. Etching - usually caused by any combination of high temperatures, soft water, soft glass, or high alkaline washing solutions. 2. Tarnishing - avoid washing silver, silver plates, and pewter in chemical sanitizing machines. 3. Pitting - stainless steel may pit with lengthy contact of foods containing salt, fruit juices, vinegar, etc. Wash immediately. 4. Black or gray marks - may have been rubbed with aluminum. 5. Brown stains - may be due to high iron content in water supply. 6. Chipping - improper loading or ware is too delicate. 7. Fading of china patterns - usually due to high water temperature and strong detergent. Check that china is dishwasher compatible. 8. Wooden ware damage - avoid washing in dishwasher. 9. Rust on cast iron - seasoning is lost in dishwasher. Avoid washing in dishwasher. 10. Plastic ware distortion - high temperatures. Check plastic ware's instructions.
Low temperature readings.	<ol style="list-style-type: none"> 1. Low water supply temperature - make sure it meets the recommended minimum temperature. 2. Rapid cycle use - if incoming water temperature is low and cycle use rate is high, the hot water supply may be insufficient to meet the demand. 3. Heavy ware load cools wash water - do not overload racks. 4. Booster heater or sump heater set low - contact your local Hobart Service Office.
Machine will not fill or will not fill high enough.	<ol style="list-style-type: none"> 1. Low water pressure - check for clogged hose strainer; ensure the site water pressure meets minimum flow pressures. 2. No water flow - main water supply valves may not be working.
Machine fills too high or leaks from door.	<ol style="list-style-type: none"> 1. Machine not level. (see LEVELING.) 2. Fill solenoid valve leaking - power the dishwasher OFF; if water continues to flow into the machine, contact your local Hobart Service Office.
Machine will not drain.	<ol style="list-style-type: none"> 1. Drain pipes restricted - check dishwasher drain line for kinks; ensure proper drain rate is allowed from plumbing. 2. Power machine OFF. Wait several seconds and then power back ON. Repeat this procedure twice if necessary. If problem persists, contact your local Hobart Service Office.
Some water occasionally drips out of rinse arms (high temperature dishwashers only).	This is normal due to expansion of water being heated in the booster tank.

NOTES