

HOBART701 S Ridge Avenue, Troy, OH 45374
1-888-4HOBART • www.hobartcorp.com**FP100
FOOD PROCESSOR****HOBART****STANDARD FEATURES**

- Red OFF, Green ON Button
- Compact Design
- Angled Front
- Planetary Drive
- Large Half Size Feed Hopper
- All Aluminum Hopper and Housing
- Interlock Switch
- Plate Speed of 420 RPMs

MODELS

- FP100 Continuous Feed Half Hopper Food Processor

Specifications, Details and Dimensions on Inside and Back.

**ACCESSORIES**

- 3-Pack Plates: $\frac{1}{16}$, $\frac{5}{32}$ slicer plates, $\frac{3}{16}$ shredder plate, 1 wall rack
- 6-Pack Plates: $\frac{1}{16}$, $\frac{5}{32}$, $\frac{3}{8}$, $\frac{7}{32}$ slicer plates, $\frac{3}{16}$ shredder plate and $\frac{3}{8}$ dicer plate, 2 wall racks
- 3-Peg Wall Rack: designed to hold three plates for additional plate storage
- Slicer Plates: $\frac{1}{32}$, $\frac{1}{16}$, $\frac{1}{8}$, $\frac{5}{32}$, $\frac{7}{32}$, $\frac{5}{16}$, $\frac{3}{8}$, $\frac{5}{8}$
- Crimping Plate: $\frac{5}{32}$
- Soft Slicing Plates: $\frac{5}{16}$, $\frac{3}{8}$, $\frac{1}{2}$, $\frac{5}{8}$
- Julienne Plates: $\frac{5}{64}$, $\frac{5}{32}$, $\frac{5}{16}$
- Dicer Grids: $\frac{7}{32}$, $\frac{5}{16}$, $\frac{3}{8}$, $\frac{1}{2}$, $\frac{5}{8}$, $\frac{3}{4}$
- Shredder Plates: $\frac{1}{16}$, $\frac{5}{64}$, $\frac{1}{8}$, $\frac{3}{16}$, $\frac{7}{32}$, $\frac{5}{16}$, $\frac{3}{8}$
- Grater Plate: Fine, Hard Cheese
- Machine Table: Adjustable height to hold Food Processor
- Adjustable height stainless steel lug cart
- Stainless steel receiving pan
- Plastic receiving pan

**FP100 FOOD PROCESSOR**

FP100 FOOD PROCESSOR



701 S Ridge Avenue, Troy, OH 45374
1-888-4HOBART • www.hobartcorp.com

SOLUTIONS/BENEFITS

Red OFF, Green ON Button

Ease of operation

Compact Design

Ease of use, small footprint, reduced labor, increased sanitation and productivity

- Occupies minimal counter space
- Unit and receiving pan fit on 23" deep counter
- Plates remove in seconds
- Feed hopper removes without tools for ease of cleaning
- Produces consistent quality product results in seconds
- Production capability for 11 lbs. per minute

Angled Front

Operator convenience, ease of use

- 50° angle for ease of product loading
- Helps to reduce operator fatigue

Planetary Drive

Performance, reliability

- Helps to prevent stalling under heavy loads
- No rest times required between loads

Large Half Size Feed Hopper

Flexibility, convenience, reduced labor

- Supports processing capabilities for large variety of products
- Design permits continuous cutting of long products
- Eliminates precutting

All Aluminum Hopper and Housing

Durability, sanitation

- Anodized finish resists harsh cleaners
- Easy clean up

Interlock Switch

Protection

- Prevents machine from running when pusher plate swings away or is open

Plate Speed of 420 RPMs

Product quality and consistency

- Precise cutting and dicing action without bruising or mashing of products



701 S Ridge Avenue, Troy, OH 45374
1-888-4HOBART • www.hobartcorp.com

FP100 FOOD PROCESSOR

SPECIFICATIONS

DESIGN: Compact, conveniently designed at 50° angle for operator convenience. Small base occupies minimal counter space. Carrying handle on back of housing designed for ease of moving unit. Housing constructed of anodized aluminum with rubber feet on base to prevent movement or skidding. Removable feed hopper is burnished aluminum. Feed hopper, pusher and deflector plate of acetal thermoplastic.

ELECTRICAL: 120/60/1, 3 Conductor power cord (18 AWG) is 6 feet in length.

MOTOR: 3.5 amps. Planetary gear driven operating at 420 RPM output. 1/3 H.P. with overload protection.

SWITCHES: Easy to operate (red) OFF and (green) ON switch. Pusher plate and feed hopper interlocks.

STANDARD EQUIPMENT: Basic unit with deflector plate and cleaning brush.

WARRANTY: Unit has full one-year warranty on parts, labor and mileage against manufacturer's defects. Service contracts are available.

CUTTING TOOLS: Slicer, julienne and shredder plates feature stainless steel plates with cutlery-grade stainless steel knives. Grater plates feature

stainless steel cutting plates with thermoplastic support hubs. Dicing grids have molded ring construction to support stainless steel knives. Plate combinations for dicing operations are shown in the table below:

FP100 Food Processors								
	DICEGRD-7/32	DICEGRD-5/16	DICEGRD-3/8	DICEGRD-1/2	DICEGRD-1/2L	DICEGRD-5/8	DICEGRD-5/8L	DICEGRD-3/4
SLICE-1/32-SS								
SLICE-1/16-SS								
SLICE-1/8-SS	✓	✓	✓	✓		✓		✓
SLICE-5/32-SS	✓	✓	✓	✓		✓		✓
SLICE-7/32-SS	✓	✓	✓	✓		✓		✓
SLICE-5/16-SS		✓	✓	✓		✓		✓
SLICE-3/8-SS			✓	✓		✓		✓
SFTSLC-5/16		✓	✓	✓		✓		✓
SFTSLC-3/8			✓	✓		✓		✓
SFTSLC-1/2					✓		✓	
SFTSLC-5/8							✓	

WEIGHT: Net - 39 lbs. Approximate Shipping - 46 lbs.

FP100 FOOD PROCESSOR



701 S Ridge Avenue, Troy, OH 45374
1-888-4HOBART • www.hobartcorp.com

DETAILS AND DIMENSIONS

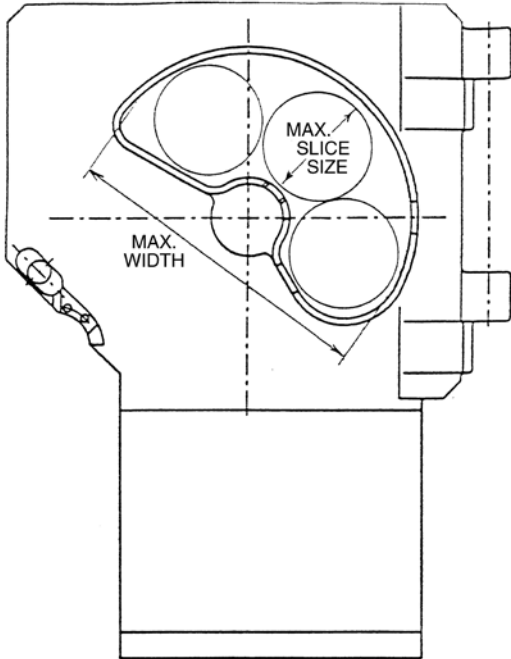

FP100	
Hopper Maximum Width	6 ³ / ₈ "
Maximum Slice Size	2 ¹ / ₂ "
Usable Depth	6"
Feed Tube Diameter	2 ¹ / ₈ "

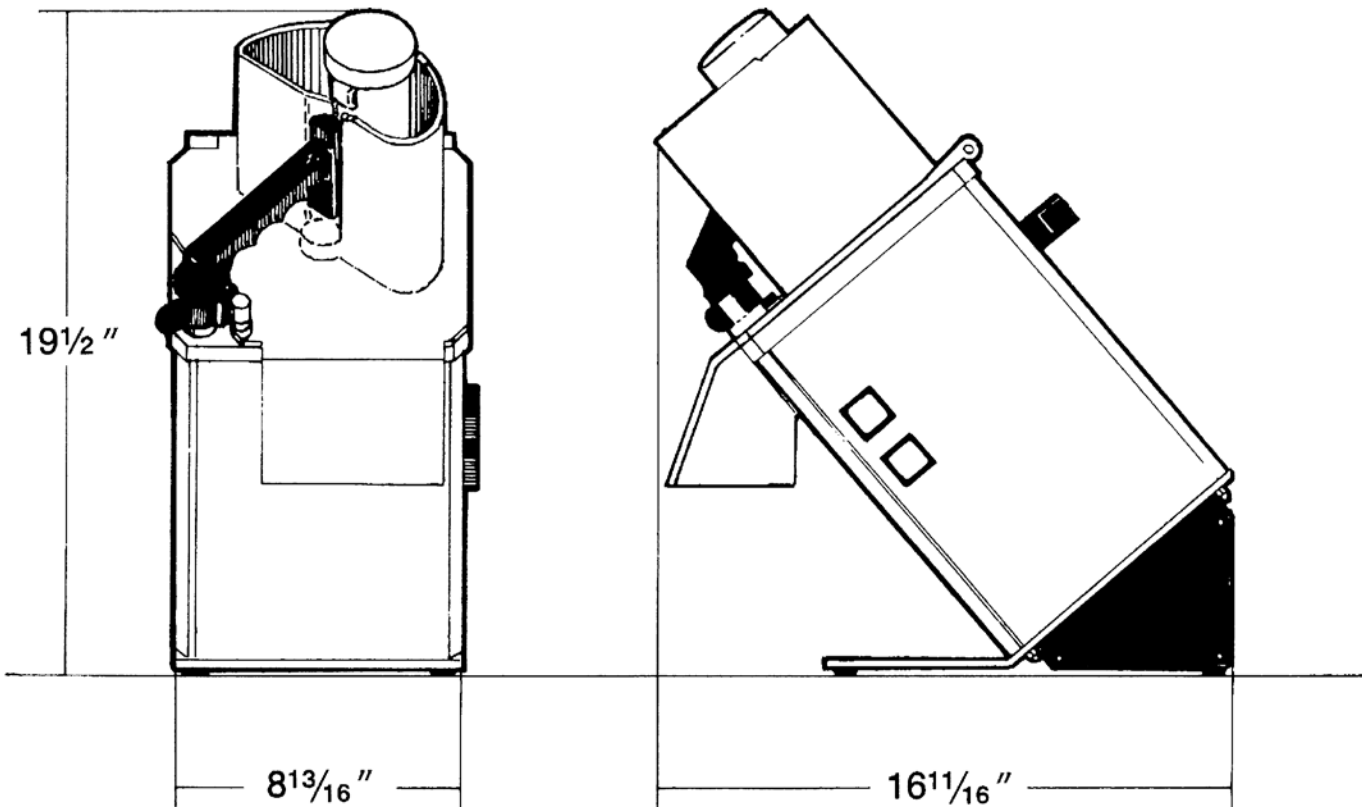

As continued product improvement is a policy of Hobart, specifications are subject to change without notice.