

INSULATED HALF-SIZE HOT CABINET H-339-128C (FOR 12" X 20" PANS)

FEATURES AND BENEFITS:

- Fully insulated half-size hot cabinet keeps prepared foods at serving temperatures. Ideal for transport.
- Powerful, yet efficient, 900 Watt heating system maintains the right temperature to properly hold products. Heats up to 200°F (93°C).
- Internal frame in body and door maintains structural rigidity.
- Body constructed of non-corrosive, Hi-Tensile aluminum for strength and ease of mobility. One piece extended base protects cabinet body.
- Safety-conscious anti-microbial latch protects against spreading germs.
- Insulated field reversible door for flexibility. Standard with right hand hinging; left hand hinging available upon request.
- Magnetic latch for "easy open"; twist-lock catch secures door during transport. Latch and hinges mounted inboard.
- Removable wire pan supports for easy cleaning hold 12" x 20" pans on 2-3/4" centers.
- Pan stops on inside of door and back allow for proper air flow.
- Convenient lift handles fold flat against sides of cabinet.
- Heavy duty 5" swivel casters, two with brakes. Provides mobility when fully loaded.
- Cabinets can be stacked for flexibility; specify optional stacking kit.



H-339-128C



NSF/ANSI 4



C US

ACCESSORIES and OPTIONS

(Available at extra cost):

- Key Lock Handle
- Stacking Kit
- Pass-Thru Version
- Pan Support Interior for 13" x 18" Trays
- Corner Bumpers
- Perimeter Bumper
- Door Window
- Various Caster Options
- Digital Thermometer
- 240 Volt Service

See page B-20 for accessory details.

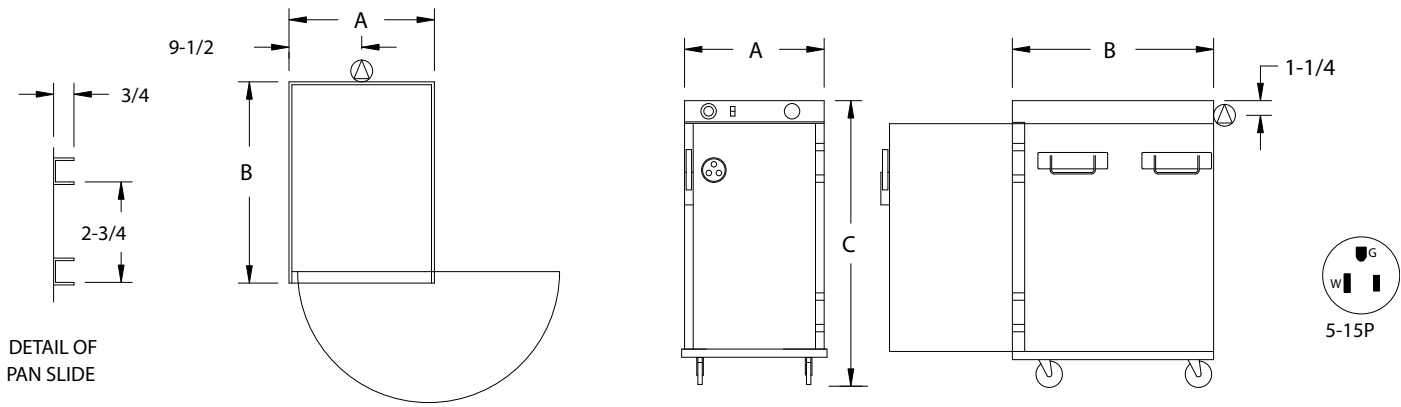

CRES COR MODEL NO.	PAN			DIM "A"	DIM "B"	DIM "C"	INSIDE DIMENSIONS				WEIGHT ACT.
	CAP	SIZE		WIDTH	DEPTH	HEIGHT	WIDTH	DEPTH	HEIGHT		
H-339-128C	8	12 x 20	IN	18-7/8	27-1/4	36-11/16	13-3/16	21-1/4	24-7/8	LBS	112
		305 x 510	MM	480	695	935	335	540	635	KG	51

NOTES: 1. When ordering bumpers, add 2" to overall dimensions.
 2. When stacking two cabinets, width will increase to 24-5/8".

CABINET:

- Body: .063 aluminum.
- Reinforcement: Internal framework of channels, 1 x 3/4 x .125.
- Insulation: Fiberglass, thermal conductivity (K factor) is .23 at 75°F. 1-1/2" in walls; 1" in door, top and bottom.
- Pan stop channels: Mounted to inside rear of cabinet and door.
- Bail handles (4): Two mounted to each side.

BASE:

- One piece construction, .190 aluminum.
- Casters: 5" dia., swivel, modulus tires, 1-1/4 wide, load cap. 250 lbs. each, temp. range -45°/+180°F. Delrin bearings. Front casters equipped with brakes.

DOOR:

- Field reversible.
- Formed .063 aluminum.
- Latch: Chrome plated zinc with composite handle, magnetic type; mounted inboard.
- Hinges: Heavy duty chrome plated zinc; mounted inboard.
- Gasket: Perimeter type, silicone.
- Transport latch.
- Vent: Adjustable.

PAN SLIDES:

- Flat wire racks, .104 x 5/8 nickel chrome plated steel, spaced on 2-3/4" centers.

ELECTRICAL COMPARTMENT:

- Cover: Formed .100 aluminum fastened to cabinet top.
- Control panel: Formed .063 aluminum; black front.
- Thermostat: Solid state, room ambient to 200°F (93°C).
- Switch: Lighted ON-OFF rocker type.
- Power cord: Removable, 6 ft., 14/3 ga. with molded straight plug.
- Heaters (3): 300 Watts each.
- Thermometer.

POWER REQUIREMENTS:

- 900 Watts, 120 Volts, 60 Hz., single phase, 7.5 Amps., 15 Amp. service.

SHORT FORM SPECIFICATIONS

Cres Cor Half-Size Insulated Hot Cabinet Model H-339-128C. Inner, outer and top liners of .063 aluminum, reinforced with channel frame. Field reversible, formed .063 aluminum door. Fiberglass insulation in walls 1-1/2"; door, top and bottom 1". Welded and finished .190 aluminum base. (3) 300 Watt inner wall heaters, 120 Volts. Removable pan supports for (8) 12" x 20" pans. Two bail handles on each side. 5" swivel modulus casters, Delrin bearings. Load capacity 250 lbs. each. 2-Year Parts / 1-Year Labor warranty. Provide the following accessories: _____ CSA-US, CSA-C, CSA to NSF4 listed.