

## INSULATED STAINLESS STEEL AQUATEMP™ HOT CABINET MODEL H-137-PWSUA-12D

### FEATURES AND BENEFITS:

- Fully insulated hot cabinet keeps prepared foods at serving temperatures.
- Powerful, yet efficient, heating system maintains the right combination of heat and humidity to properly hold products. 2000 Watts of heat holds food at up to 200°F (93°C).
- AquaTemp system maintains optimum food texture through continuous monitoring of both temperature and humidity. Temperature and humidity values are measured, displayed and controlled through intuitive solid state controller. Air temperature is prioritized over humidity to ensure food safety. Low water indicating LED and water heater shut off when water is at critically low level.
- Stainless steel construction throughout with internal frame in body and doors plus reinforced internal base maintains structural rigidity.
- Smooth interior coved corners prevent food particle/grease buildup.
- Pass-thru design allows for easy access from preparation area and serving areas.
- Field reversible insulated Dutch doors on front and back with anti-microbial latches prevent temperature loss and protect against spreading germs. Silicone door gaskets for proper seal.
- Standard with right hand hinging; left hand hinging available upon request.
- High temperature ceramic magnetic latches for "easy open"; twist-lock catch keeps doors securely closed.
- Recessed push/pull handles on both sides prevent damage to walls; allows easy maneuvering.
- Twelve sets of stainless steel wire universal angles accommodate a large variety of pan sizes on adjustable 1-1/2" centers.
- Integral drip trough on front keeps traffic area dry, safer.
- Heavy duty 5" swivel casters, two with brakes. Provides mobility when fully loaded.



H-137-PWSUA-12D



New, easier to use, easy-to-read and operate LED digital display ensures holding at precise food temperatures and moisture content.

### ACCESSORIES and OPTIONS (Available at extra cost):

- Automatic Water Fill System
- Tempered Glass Door Windows
- Lock Hasp
- Side Bumper Kit
- Extra Universal Angles
- 208 or 240 Volt Service
- 1500 Watt, 15 Amp. Power Unit
- HACCP Documentation (Built-in USB port)

See page B-20 for accessory details.



# H-137-PWSUA-12D

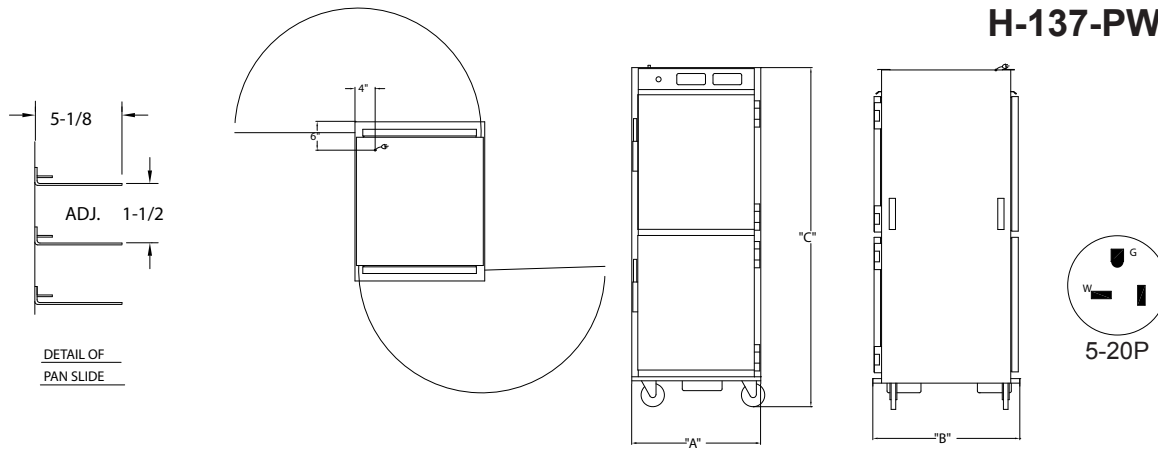

CRES COR MODEL NO.	PAN			DIM "A"	DIM "B"	DIM "C"	INSIDE DIMENSIONS				WEIGHT ACT.
	CAP/ ANGLES	SIZE		WIDTH	DEPTH	HEIGHT	WIDTH	DEPTH	HEIGHT		
H-137-PWSUA-12D	12 SETS	SEE NOTE BELOW	IN	28-1/4	34-5/8	73-1/2	21-3/4	26-7/8	58	LBS	328
			MM	720	880	1865	555	685	1475	KG	149

NOTES: 1. Pan sizes 22" x 20" (560 x 510) Roast & Bake Pans, 10" x 20" (255 x 510) Roast & Bake Pans, 18" x 26" (460 x 660) Bun Pans, 14" x 18" (355 x 460) Service Trays, 12" x 20" (305 x 510) Steam Table Pans.  
Refer to Pan Size Chart at end of section.

2. When ordering bumpers, add 2" to overall dimensions.



Gold indicates our Best Insulated Hot Cabinets with the best warranty in the industry.  
3-Year Parts / 1-Year Labor.

## CABINET:

- Body: 22 ga. stainless steel.
- Reinforcement: Internal framework of 18 ga. stainless steel.
- Insulation: Fiberglass, thermal conductivity (K factor) is .23 at 75°F. 1-1/2" in doors, top, base; 2" in sidewalls.
- Air tunnels: 22 ga. stainless steel; lift-out type, mounted on sides.
- Push/pull handles (4): 5" vertical; recessed.
- Interior coved corners.

## BASE:

- One piece construction, .125 aluminum.
- Drip troughs: Formed 18 ga. stainless steel mounted to front and rear of cabinet; removable drip pans.
- Casters: 5" dia., swivel, modulus tires, 1-1/4 wide, load cap. 250 lbs. each, temp. range -45°/+180°F. Delrin bearings. Front casters equipped with brakes.

## DUTCH DOORS:

- Field reversible.
- Formed 22 ga. stainless steel.
- Latches: Chrome plated zinc, high temperature ceramic magnetic type.
- Transport Latches.
- Hinges: Heavy duty chrome plated zinc.
- Gaskets: Perimeter type, silicone.
- Pan stops: Embossed.

## PAN SLIDES:

- Stainless steel wire universal angles (.306 dia.), mounted on lift-out posts.
- Spaced on 4-1/2" centers; adjustable on 1-1/2" centers.



Scan QR code to view Spec Sheet, Operating Manual, Wiring Diagram or to call Customer Service.

If you need a QR reader visit your App Store on your Smartphone or Tablet.



5925 Heisley Road • Mentor, OH 44060-1833  
Phone: 877/CRESCOR • Fax: 440/350-7267  
www.crescor.com

© Crescent Metal Products, Inc. 2017 All rights reserved.

## HOT UNIT COMPONENTS:

- Thermostat (holding): Solid state digital display control, room ambient to 200°F (93°C).
- Thermostat (humidity): Solid state digital display control, room ambient to 95%.
- Switch: ON-OFF push button type.
- Power cord: Permanent, 10 ft., 12/3 ga.
- Heater: 2000 Watts for holding.
- Blower motor.
- Vent fan.
- Water pan: 4 gallons; 16 ga. stainless steel with 1850 Watt heater for humidity.
- Thermometer: Digital.

## POWER REQUIREMENTS:

- 2000 Watts, 120 Volts, 60 Hz., single phase, 16 Amps., 20 Amp. service.

## SHORT FORM SPECIFICATIONS

Cres Cor Insulated AquaTemp Hot Cabinet Model H-137-PWSUA-12D. Solid state electronic controlled time, temperature and moisture content. Cabinet 22 ga. stainless steel; stainless steel internal frame. (12) sets stainless steel wire universal angles for multiple pan sizes, adjustable spacing every 1-1/2". Field reversible Dutch doors, 22 ga. stainless steel. Fiberglass insulation in sides 2"; doors, top, base 1-1/2". Interior coved corners. 2000 Watt, 120 Volt power unit; adjustable heat and humidity. One piece insulated base, .125 aluminum. 5" swivel modulus casters, Delrin bearings. Load capacity 250 lbs. each. 3-Year Parts/ 1-Year Labor warranty. Provide the following accessories: \_\_\_\_\_ . NSF, CSA-US, CSA-C listed.

*In line with its policy to continually improve its products, CRES COR reserves the right to change materials and specifications without notice.*

Made in America Since 1936