

Parts Catalog



SP80PL

MIXERS

MODELS: SP80PL & SPC80PL

12-18-14

IMPORTANT!

TO EXPEDITE SHIPMENT OF PARTS, ALWAYS SPECIFY MODEL, REV,
PART NUMBER, AND SERIAL NUMBER OF MIXER.

GLOBE FOOD EQUIPMENT COMPANY

2215 East River Road
Dayton, Ohio 45439

Parts Department

Toll Free 1-800-745-6238 · Fax (937) 290-0585

E-Mail: info@globefoodequip.com

Website: www.globefoodequip.com

Not for resale

TABLE OF CONTENTS

	Page
Mixer Base	1 - 2
Head And Hub Assembly	3 - 4
Manual Lift Cradle Assembly	5 - 6
Power Lift Cradle Assembly	7 - 8
Gearbox Components	9 - 10
Gear Shift Assembly	11
Bowl Scraper Components	12
Planetary Components and Fixed Bowl Guard	13 - 14
Motor Components	15
Motor Brake - SPC Models Only	16
Manual Lift Controls	17
Power Lift Controls	18
Wiring Diagram, Manual Lift Mixer	19
Wiring Diagram, Power Lift Mixer	20
Power Lift Mixer Schematic, 220V	21
Wiring Diagram, Power Lift Mixer - SPC Model	22
Wiring Diagram, Power Lift Mixer - Digital Control Panel	23

SP80PL MIXER BASE

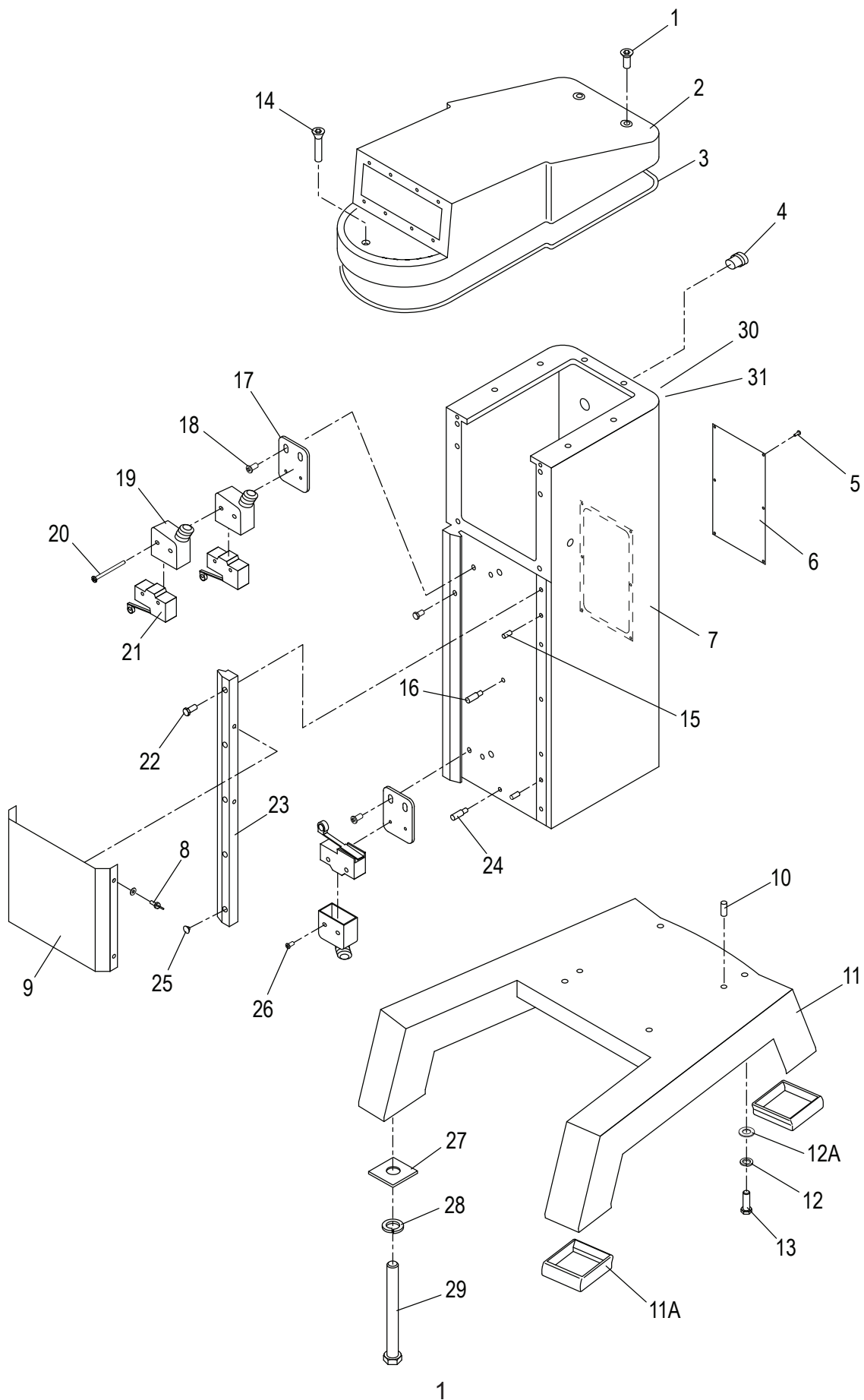

SP80PL MIXER BASE COMPONENTS

Item	Description	Part Number	Qty	Hardware
1	Screw, Flat Head	X80A01	2	M8x85mm
2	Cover, Transmission Case	X80A02	1	
		*X80A02-DG		
3	Gasket	X80A03	1	
4	Strain Relief	X80A04	1	
5	Screw, Truss Head	X80A05	6	M5x12mm
6	Plate, Rear Column	X80A06	1	
7	Mixer Column	-	1	
8	Thumbscrew	X80A08	4	M5x12mm
9	Cover, Column Front	X80A09	1	
10	Dowel Pin, Column Locator	X80A10	2	Ø10 x 34mm
11	Mixer Base	X80A11	1	
		*X80A11-DG		
11A	Rubber Feet Set (Front/Rear)	X80A11-1	1	
12A	Washer, Flat	X80A12-1	4	M14
12	Washer, Split Lock	X80A12	4	M14
13	Screw, Hex Head	X80A13	4	M14x50mm
14	Screw, Flat Head	X80A14	1	M8x85mm
15	Dowel Pin	X80A15	2	Ø10 x 33mm
16	Dowel Pin, Threaded	X80A16	1	
17	Plate, Microswitch Mounting	X80A17	2	
18	Screw, Truss Head	X80A18	4	M5x12mm
19	Housing, Microswitch	X80A19	3	
20	Screw, Hex Head & Flat Washer	X80A20	2	M4x45mm
21	Microswitch	X80A21	3	
	Microswitch, SPC Models	X80A21-1		
22	Screw, Hex Head & Flat Washer	X80A22	5	M12x25mm
23	Slide, Front Bowl, Right (Cast Iron)	X80A23	1	
	Slide, Front Bowl, Left (Metal Sheet)	**X80A23-1	1	
24	Dowel Pin, Threaded	X80A24	1	
25	Plug, Plastic	-	5	
26	Screw, Round Head	X80A37	2	M4x25mm
27	Washer, Shipping (Square)	X80A31	4	M12
28	Washer, Split Lock	-	4	M12
29	Shipping Bolt, Hex Head - Grade 10.9	X80A32	4	M12x100mm
30	Label, Hazardous Voltage	X91014	1	
31	Label, Caution - 3 Phase	X91011	1	

*Use after S/N 7810290.

**Use after S/N 7810150.

SP80PL HEAD AND HUB ASSY PARTS LIST

Item	Description	Part Number	Qty	Hardware
1	Screw, Hex Head	X80B01	1	M10x14mm
2	Washer, Split Lock	X80B02	1	M10
3	Washer, Flat	X80B03	1	M10
4	Screw, Hex Head	X80B04	2	M12x40mm
5	Washer, Split Lock	X80B05	2	M12
6	Washer, Flat	X80B06	2	M12
7	Gauge, Oil Level	X80B07	1	
8	Transmission Case, Fixed Bowl Guard	X80B08	1	
9	Washer, Flat	X80B09	6	M12
10	Washer, Split Lock	X80B10	6	M12
11	Screw, Hex Head	X80B11	6	M12x38mm
12	Oil Seal	X80B12	1	TC50x80x10
13	Oil Pump Assembly	X80B13-27	1	
13A	Plate, Oil Pump - Bottom	X80B13	1	
14	Gear, Oil Pump, Right (15T)	X80B14	1	
15	Gear, Oil Pump, Left (15T)	X80B15	1	
16	Gear Set Pump	X80B16	1	
17	Housing & Tube Assy	X80B17-19	1	
	Pump Outlet Bronze Pipe	-	1	
	Pump Shaft Bushing	-	1	
18	Washer, Split Lock	X80B26	4	M5
19	Cap Screw, Socket Head	X80B27	2	M5x15mm
20	Cap Screw, Socket Head	-	2	M5x25mm
21	Roll Pin	X80B22	1	Ø2x10mm
22	Shaft, Oil Pump	X80B21	1	
23	Roll Pin	X80B20	1	Ø2x18mm
*24	Conveying Gear Bushing	X80B23	1	
*25	Conveying Gear (29T)	X80B24	1	
*26	Nut, Jam	-	1	M12
27	Cover, Transmission Case	X80B25	1	
28	Gasket, Transmission Cover	X80B40	1	
29	Dowel Pin, Threaded	X80B39	2	
30	Washer, Split Lock	X30198	11	M8
31	Screw, Hex Head	X30197	9	M8x35mm
32	Screw, Socket Head	X30099	2	M8x28mm
33	Top Cover	X80B33	1	
34	Gasket, Xmission Shaft Bearing Retainer	X80B28	1	
*35	Bearing Retainer, Transmission Shaft	X80B29	1	
36	Screw, Hex Head	X80B30	3	M4x12mm
37	Washer, Flat	X80B31	1	M20
*38	Oil Fill Plug	X80B32	1	
39	Hose Assembly	X00703	1	
*	Grease Fitting	-	1	
*	Hose Clamp	-	1	
40	Gasket, Shaft Bearing Retainer	X80B36	1	
*41	Bearing Retainer, Drive Shaft	X80B35	1	
42	Screw, Truss Head	X80B34	3	M4x14mm
*43	Oil Fill Plug	X00704	1	
44	Oil Tube And Gasket	X80B42-43	1	
45	Gasket, Lube Overflow Cylinder	-	1	
46	Lube Overflow Cylinder	-	1	
47	Screw, Flat Head	X80B41	5	M6x14mm
48	Dowel Pin	X80B56	2	Ø10 x 20mm
49	Level Drive Gear (16T)	X80B44	1	
50	Hub Attachment Assembly	X80B45-52	1	
51	Thrust Washer	X80B45	A/R	
52	Sleeve, Square Drive	X80B46	2	
53	Oil Seal	X10089	1	
54	Gasket, Attachment Hub	X80B48	1	
55	Hub, Attachment	X80B50	1	
		**X80B50-DG		
56	Screw, Socket Head	X80B52	3	M6X25mm
57	Thumb Screw	X10005	1	1/2-13x3/4"
58	Hole Plug, Attachment	X80B51	1	
59	Cover Plate, Transmission	X80B53	1	
60	Screw, Hex Head	X80B54	4	M5x10mm
61	Dowel Pin	X80B55	1	
62	Screw, Socket Head	X80E09	4	M8x25mm
63	Label, Globe Logo	871-3	1	
64	Label, Arrow	X91012	1	
65	Label, Stop To Change Gears	X91010	1	
66	Label, Warning	X91015	1	
67	Label, Warning, French (Canada Only)	X91007-F	1	

*Part configuration may vary. **Use after S/N 7810290.

SP80PL MANUAL LIFT CRADLE ASSEMBLY

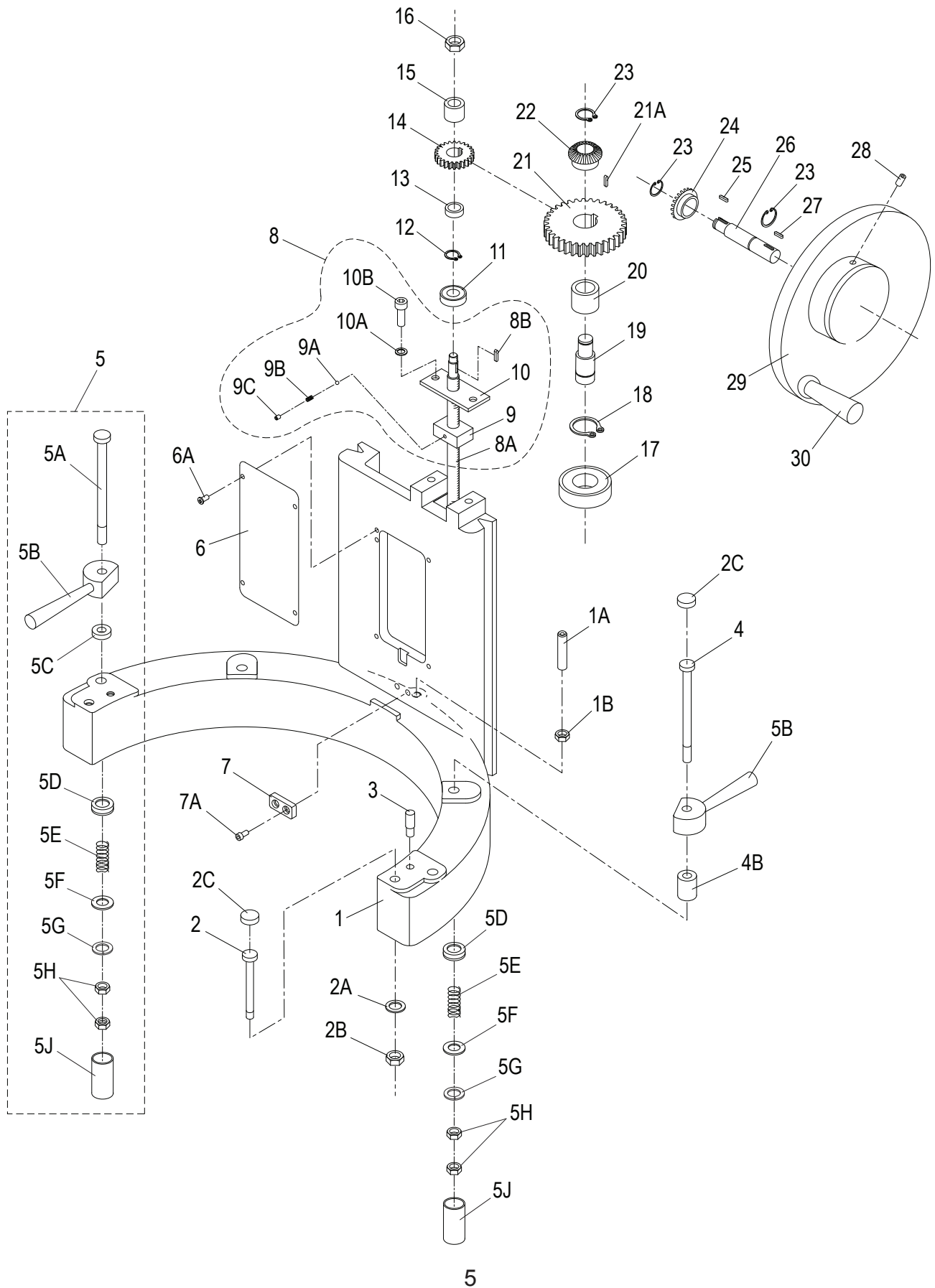

SP80PL MANUAL LIFT CRADLE ASSY PARTS LIST

Item	Description	Part Number	Qty	Hardware
1	Bowl Cradle	X80C12	1	
1A	Set Screw, Socket Head - Cup Pt	-	1	M12x80mm
1B	Nut, Hex	-	1	M12
2	Bowl Locating Screw	X80C13	2	M10
2A	Washer, Split Lock	X80C11	2	M12
2B	Nut, Acorn	X80C10	2	M12
2C	Screw Cover	-	4	
3	Dowel Pin, Threaded	X80C14	2	
4	Clamp Screw, Rear	X80C09	2	
4B	Bronze Bushing Rear	X80C07	2	
5	Bowl Clamp Assembly	X80C05	2	
5A	Bowl Clamp Screw	X80C06	2	
5B	Bowl Clamp	X80C05-1	4	
5C	Bronze Bushing, Front	X80C04	2	
5D	Hardware Cap Retainer	-	4	
5E	Spring	X80C03	4	
5F	Washer, Flat	X80B09	4	M12
5G	Washer, Split Lock	-	4	M12
5H	Nut, Jam	X80C01	4	M12
5J	Hardware Cap	-	4	
6	Bowl Cradle Frnt Cover	X80C17	1	
6A	Screw, Hex Head	X80C18	4	M5x10mm
7	Locking Bracket	X80C16	1	
7A	Screw, Socket Head & Lock Washer	X80C15	2	M8x35mm
8	Bowl Lift Screw Assembly	X80C19-24		
8A	Bowl Raise Screw	-	1	
8B	Shaft Key	X80H55	2	6x6x25mm
9	Nut, Bowl Lift	-	1	
9A	Roller	-	1	
9B	Spring	-	1	
9C	Set Screw, Socket Head - Cup Pt	-	1	M6x5mm
10	Plate, Nut Mounting	-	1	
10A	Washer, Split Lock	-	1	M10
10B	Screw, Socket Head	-	2	M10x20mm
11	Ball Bearing	X80C25	1	
12	Retaining Ring	X80C26	1	RTW-40
13	Bronze Bushing, Lower	X80C27	1	
14	Oblique Gear (31T)	X80C28	1	
15	Bronze Bushing, Upper	X80C29	1	
16	Nut, Hex	-	1	M16
17	Ball Bearing	X80C31	1	
18	Retaining Ring	X80C32	1	STW-25
19	Drive Shaft	X80C33	1	
20	Oblique Shaft Sleeve	X80C34	1	
21	Oblique Gear (41T)	X80C35	1	
21A	Shaft Key	X80C36	1	3x3x12mm
22	Gear, Male (23T)	X80C37	1	
23	Retaining Ring	X80C38	3	STW-19
24	Gear, Female (23T)	X80C40	1	
25	Shaft Key	X80C41	1	5x5x18mm
26	Hand Wheel Shaft	X80C42	1	
27	Shaft Key	X80C44	1	5x5x25mm
28	Set Screw, Socket Head - Cup Pt	X80C45	1	M8x16mm
29	Hand Wheel	X80C46	1	
30	Handle	X80C47	1	

SP80PL POWER LIFT CRADLE ASSEMBLY

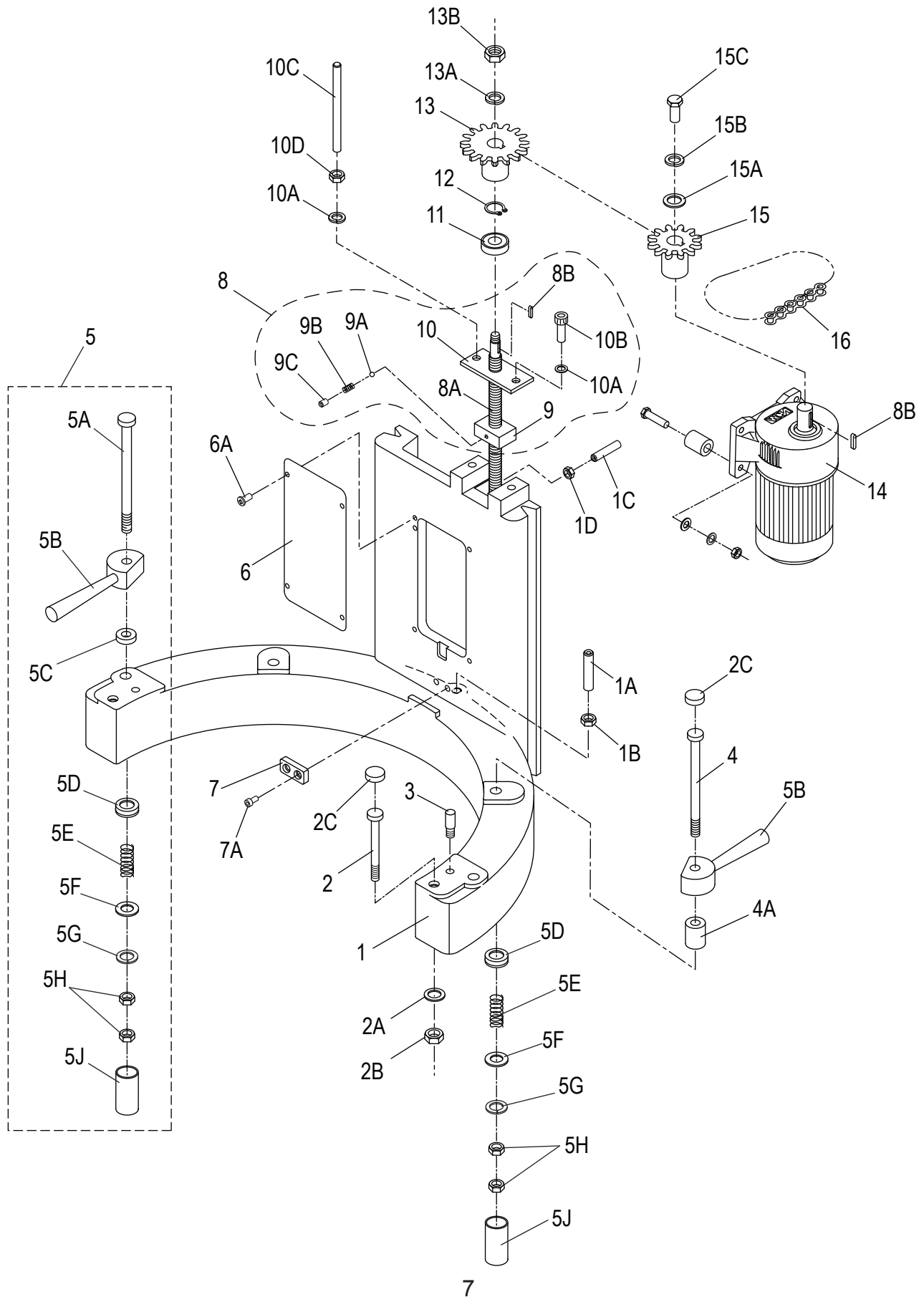

SP80PL POWER LIFT CRADLE ASSY PARTS LIST

Item	Description	Part Number	Qty	Hardware
1	Bowl Cradle	X80C12	1	
1A	Set Screw, Socket Head - Cup Point	-	1	M12x80mm
1B	Nut, Hex	-	1	M12
1C	Set Screw, Socket Head - Cup Point	-	1	M6x40mm
1D	Nut, Hex	-	1	M6
2	Bowl Locating Screw	X80C13	2	M10
2A	Washer, Split Lock	X80C11	2	M12
2B	Nut, Acorn	X80C10	2	M12
2C	Screw Cover	-	4	
3	Dowel Pin, Threaded	X80C14	2	
4	Screw, Bowl Clamp - Rear	X80C09	2	
4A	Bushing, Bronze - Rear Clamp	X80C07	2	
5	Bowl Clamp Assembly	X80C05	2	
5A	Screw, Bowl Clamp - Front	X80C06	2	
5B	Bowl Clamp	X80C05-1	2	
5C	Bushing, Bronze - Front	X80C04	2	
5D	Hardware Cap	-	4	
5E	Spring	X80C03	4	
5F	Washer, Flat	X80B09	4	M12
5G	Washer, Split Lock	X80C02	4	M12
5H	Nut, Jam	X80C01	4	M12
5J	Hardware Cap	-	4	-
6	Front Cover, Bowl Cradle	X80C17	1	
6A	Screw, Hex Head	X80C18	4	M5x10mm
7	Locking Bracket	X80C16	1	
7A	Screw, Socket Head & Lock Washer	X80C15	2	M8x35mm
8	Bowl Raise Screw Assembly	X80C19-24	1	
8A	Bowl Raise Screw	-	1	
8B	Shaft Key	X80H55	2	6x6x25mm
9	Nut Block	-	1	
9A	Roller Ball	-	1	Ø5 SS
9B	Spring	-	1	
9C	Set Screw, Socket Head - Cup Point	-	1	M6x5mm
10	Nut Mounting Plate	-	1	
10A	Washer, Split Lock	-	2	M10
10B	Screw, Socket Head	-	1	M10x20mm
10C	Rod, Threaded	-	1	M10x160mm
10D	Nut, Hex	-	1	M10
11	Ball Bearing	X80C25	1	
12	Retaining Ring	X80C26	1	R40
13	Chain Gear (16T)	X80H48	1	
13A	Washer, Split Lock	X80H49	1	M16
13B	Nut, Hex	X80C30	1	M16
14	Motor, 1/8Hp 220V 50/60Hz 1Ph, Prior To S/N 7810151	X00705	1	
	Motor, 1/8Hp 220V 50/60Hz 3Ph, Prior To S/N 7810151	X80H56	1	
	Motor, Metal Plate, 220/380V/60Hz/1Ph Starting S/N 7810151	XA-8038-1	1	
	Motor, Metal Plate, 220/380V/60Hz/3Ph Starting S/N 7810151	XA-8038-3	1	
15	Chain Gear (11T)	X80H53	1	
15A	Washer, Flat	X80H52	1	M6
15B	Washer, Split Lock	X80H51	1	M6
15C	Screw, Hex Head	X80H50	1	M6x16mm
16	Drive Chain	X80H54	1	

SP80PL GEARBOX COMPONENTS

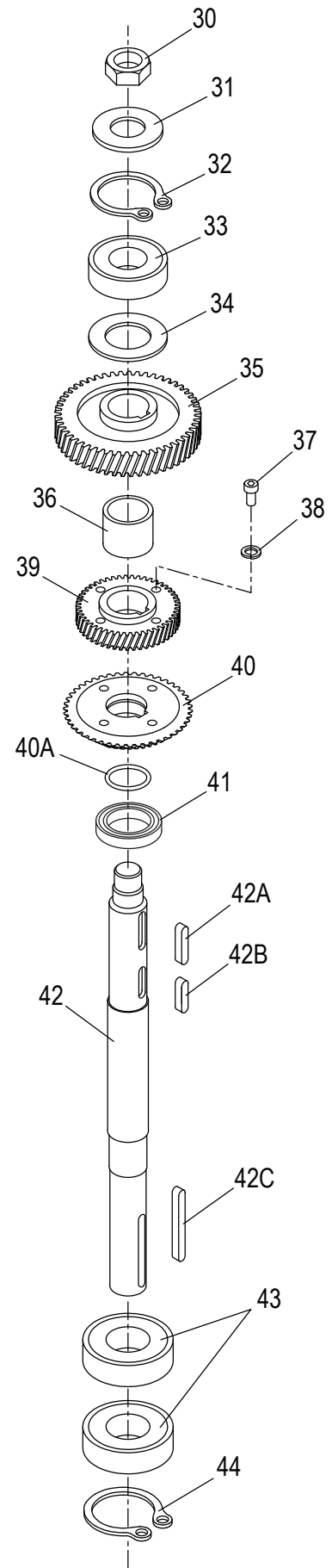
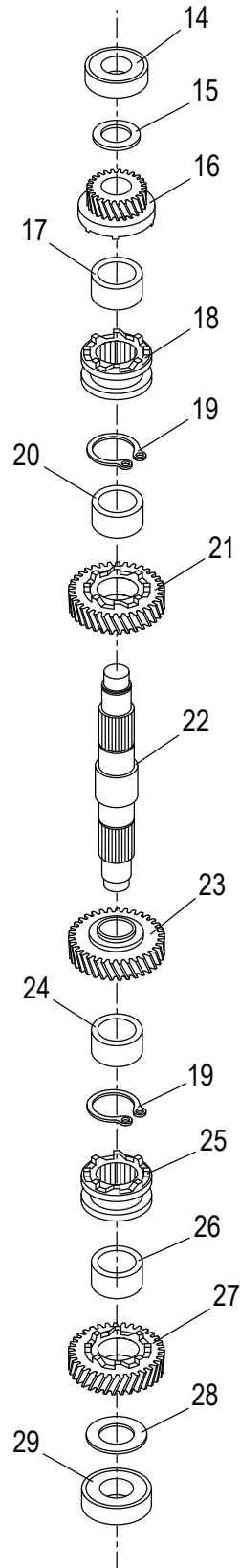
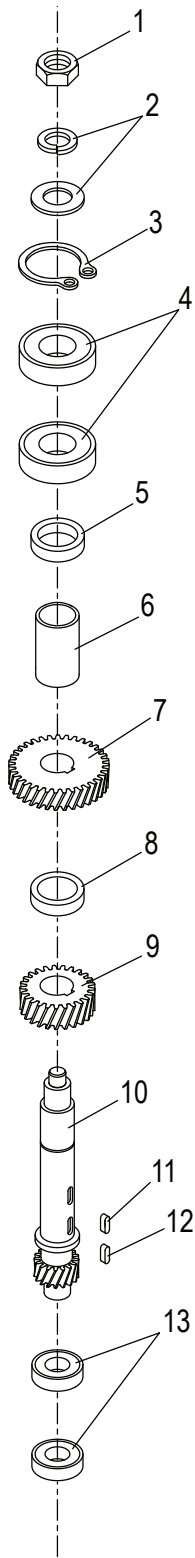

SP80PL GEARBOX PARTS LIST

Item	Description	Part Number	Qty	Hardware
1	Nut, Jam	X80D34	1	M16
2	Washer, Split Lock & Flat	X80D35	1	M16
3	Retaining Ring	X80D36	1	RTW-47
4	Ball Bearing	X80D37	2	
5	Spacer	X80D38	1	
6	Sleeve	X80D38-1	1	
*7	Worm Gear (29T) (220V Mixer)	X80D39G03-1	1	
	Worm Gear (29T) (350V Mixer)	X80D39G03		
8	Bronze Bushing	X80D40	1	
9	Transmission Gear (25T)	X80D41	1	
10	Transmission Shaft (17T)	X80D42	1	
11	Shaft Key	X80D43	1	6x6x18mm
12	Shaft Key	X80D44	1	8x8x20mm
13	Ball Bearing	X80D45	2	
14	Ball Bearing	X80D17	1	
15	Master Shaft Pad	X80D18	1	
16	Master Shaft Gear (17T)	X80D19	1	
17	Bronze Bushing	X80D20	1	
18	Clutch Sleeve	X80D21	1	
19	Retaining Ring	X80D22	2	STW-35
20	Bronze Bushing	X80D23	1	
21	Master Shaft Gear (33T)	X80D24	1	
22	Master Shaft	X80D25	1	
23	Master Shaft Gear (41T)	X80D26	1	
24	Bronze Bushing	X80D23	1	
25	Clutch Sleeve	X80D21	1	
26	Bronze Bushing	X80D30	1	
27	Master Shaft Gear (49T)	X80D31	1	
28	Spacer	X80D32	1	29x40x3mm
29	Ball Bearing	X80D33	1	
30	Jam Nut	X80D16	1	M32
31	Washer, Flat	X80D15	1	M32
32	Retaining Ring	X80D14	1	RTW-72
33	Ball Bearing	X30125	1	
34	Drive Shaft Pad	X80D12	1	
35	Drive Shaft Gear (53T)	X80D11	1	
36	Bronze Bushing	X80D10	1	
37	Screw, Socket Head	X80D09	4	M8x28mm
38	Washer, Split Lock	X80D08	4	M8
39	Main Shaft Gear (35T)	X80D07	1	
40	Gear (41T)	X80D06	1	
40A	O-Ring (Fits Inside Dia Of X80D06)	X80D05	1	40mm x 50mm ID
41	Oil Seal	X80D02-2	1	
42	Drive Shaft, Prior To S/N 7810173	X80D02	1	
	Drive Shaft, Starting S/N 7810173	X80D02-1		
42A	Shaft Key	X80D04	1	10x10x35mm
42B	Shaft Key	X80D03	1	10x10x26mm
42C	Shaft Key	X80D01	1	10x10x100mm
43	Ball Bearing	X80D46	2	
44	Retaining Ring	X80D47	1	RTW-75

* Included with Worm Drive (Page 15). Worm Gear and Worm Drive must be replaced at same time.

SP80PL GEAR SHIFT ASSEMBLY

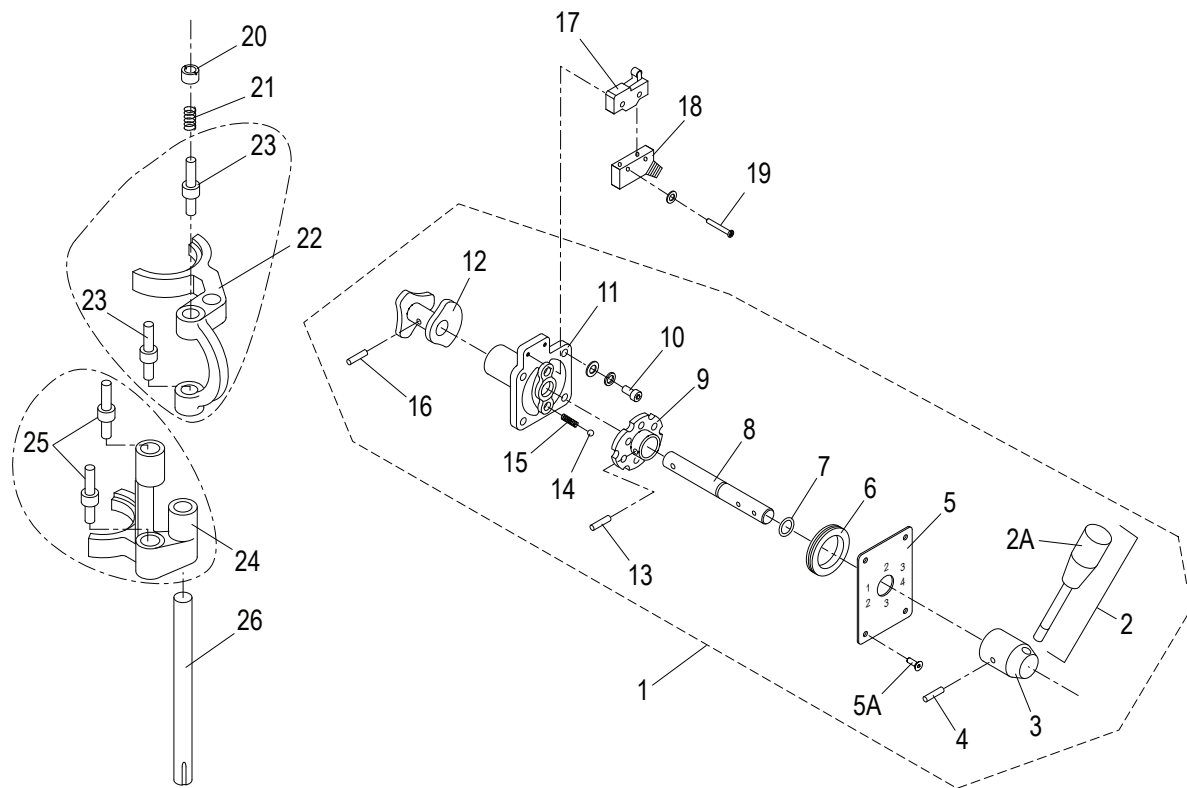

Item	Description	Part Number	Qty	Hardware
1	Gear Shift Assembly	X80E01-15	1	
2	Gear Shift Arm Assy (With Knob)	X80E01	1	
2A	Knob, Gear Shift	X80E01-1	1	
3	Gear Shift Arm Hub	X80E02	1	
4	Roll Pin	X80E03	1	Ø6 x 38mm
5	1-4 Speed Indication Plate	X80E04	1	
5A	Screw, Flat Head	-	4	M5x14mm
6	Oil Seal	X80E05	1	
7	O-Ring	X80E06	1	P11
8	Shifter Guide Rod	X80E07	1	
9	Hub & Cam Assy	X80E08	1	
10	Screw, Socket Head	-	4	M8x25mm
11	Shaft Cover	X80E10	1	
12	Gear Shift Cam Assy	X80E11	1	
13	Roll Pin	X80E12	1	Ø5 X 26mm
14	Steel Ball	X80E13	2	Ø9mm
15	Spring	X80E14	2	
16	Roll Pin	X80E15	1	Ø6 x 20mm
17	Microswitch	X80E16	1	
18	Microswitch Cover	X80E17	1	
19	Screw, Pan Head & Flat Washer	X80E18	2	M4x24mm
20	Nut	X80E19	4	M20
21	Spring	X80E20	4	
22	Speed Shifter Yoke (Top)	X80E22	1	
23	Touch Shaft	X80E21	2	
24	Speed Shifter Yoke (Rear)	X80E23	1	
25	Touch Shaft	X80E21	2	
26	Shifter Guide Rod	X80E24	1	

SP80PL BOWL SCRAPER COMPONENTS

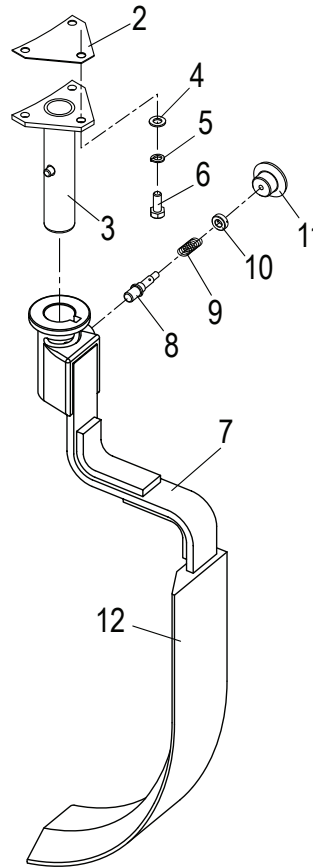

Item	Description	Part Number	Qty	Hardware
*1	Bowl Scraper Assembly	XXSCRP-80	1	
2	Shaft Spacer	X80519	1	
3	Scraper Hub	X80J520	1	
4	Washer, Flat	-	3	M8
5	Washer, Split Lock	-	3	M8
6	Screw, Hex Head - SS	-	3	M8x20mm
7	Scraper Attachment Arm	X80521	1	
8	Pin	X80522	1	
9	Spring	X80523	1	
10	Spacer	X80524	1	
11	Knob	X80525	1	
12	Bowl Scraper	X80526	1	

*Available After S/N 7810035

SP80PL PLANETARY COMPONENTS & FIXED BOWL GUARD

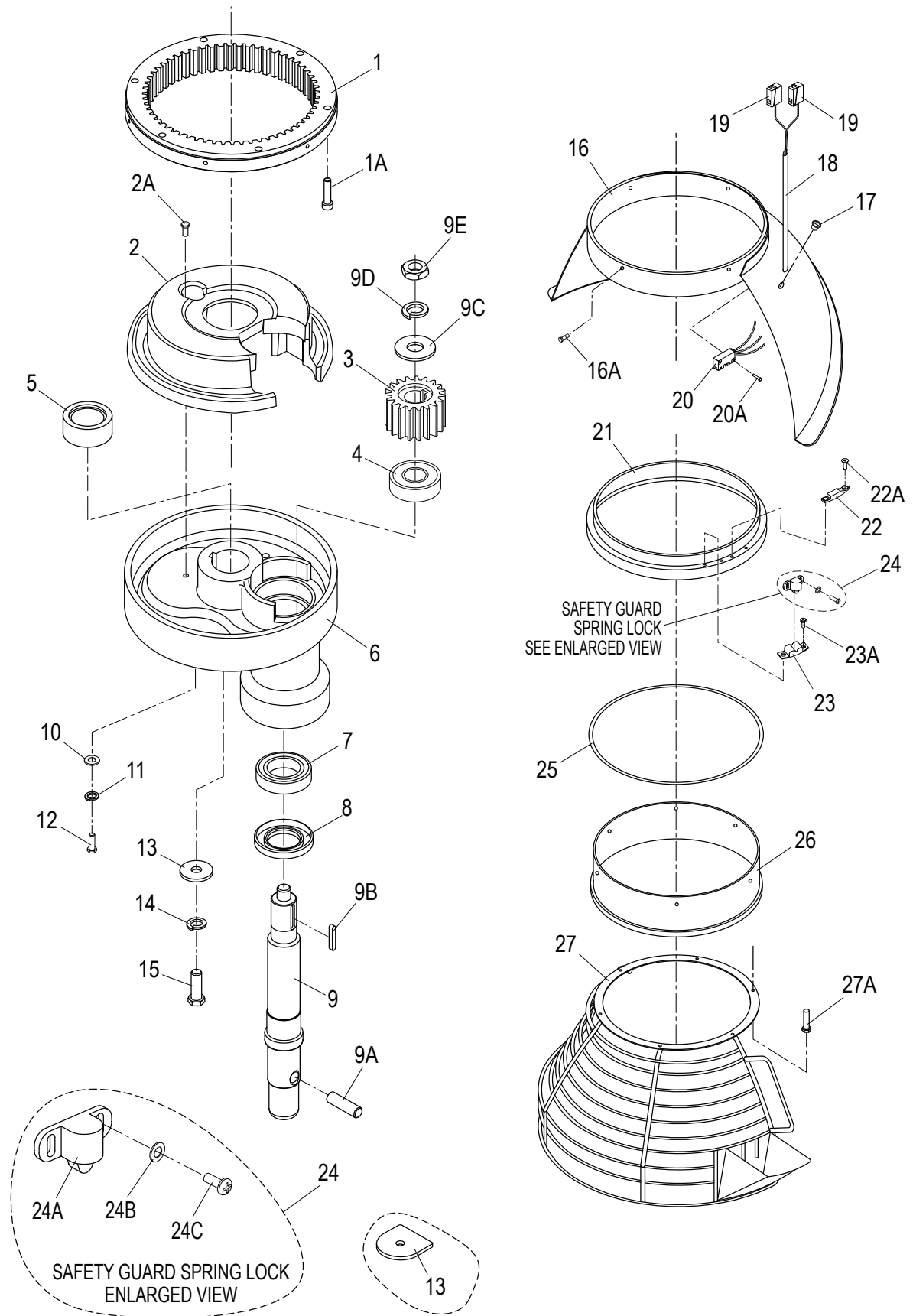

SP80PL PLANETARY & FIXED BOWL GUARD PARTS LIST

Item	Description	Part Number	Qty	Hardware
1	Planetary Gear (59T)	X80F01	1	
1A	Screw, Socket Head	X80F03	6	M8x35mm
2	Oil Cover, Old Style	X80F09-1	1	
	Oil Cover, New Style (After S/N 8810006)	X80F09-2		
2A	Screw, Hex Head	-	1	
3	Pinion Gear (18T)	X80F06	1	
4	Ball Bearing	X80F07	1	
5	Guard Oil Bushing	X80F18	1	
6	Planetary Holder, Old Style (Before S/N 8810007)	X62F09	1	
	Planetary Holder, New Style (After S/N 8810006)	X80F09		
		*X80F09-DG		
7	Ball Bearing	X80F10	1	
8	Oil Seal	X80F11	1	40x72x12
9	Planetary Shaft (Before S/N 7810173)	X62F13	1	
	Planetary Shaft (After S/N 7810172)	X80F13-1		
9A	Planetary Shaft Pin	X80F14	1	
9B	Shaft Key	X80F12	1	6x6x35mm
9C	Washer, Flat	X80F05	1	M16
9D	Washer, Split Lock	X80F04	1	M16
9E	Nut, Jam	X80F02	1	M16
10	Washer, Flat	X80F20	2	M10
11	Washer, Split Lock	X80F21	2	M10
12	Screw, Hex Head - SS	X80F22	2	M10x20mm
13	Washer, Flat - Round (Before S/N 7810173)	X80F23	1	M8
	Washer, Flat - D Shape (After S/N 7810172)	X80F23-1		M10
14	Washer, Split Lock (Before S/N 7810173)	X80F24	1	M8
	Washer, Split Lock (After S/N 7810172)	X80F24-1		M10
15	Screw, Hex Head (Before S/N 7810173)	X80F25	1	M8x25mm
	Screw, Hex Head (After S/N 7810172)	X80F25-1		M10x25mm
16	Rear Guard, Fixed	X80J32-33	1	
16A	Screw, Hex Head - SS	X80F16	6	M5x12mm
17	Access Plug	X80J34	2	
18	Tube Wireway	X80J31A1	1	
19	Connector	X80J31	2	
20	Microswitch, Safety Interlock (Before S/N 7810122)	X80J35	1	
	Microswitch, Safety Interlock (After S/N 7810121)	X80J35-1		
	Microswitch, Safety Interlock - SPC Models	X80J35-2		
20A	Screw, Socket Head	X80J36	2	M3x16mm
21	Slide Sheath, Old Style (Before S/N 7810122)	X80J43	1	
	Slide Sheath, New Style (After S/N 7810121)	X80J43-1		
22	Touch Mass (Before S/N 7810122 Only)	X10041	1	
	Touch Mass (After S/N 7810121 Only)	X80J43-1	1	
22A	Screw, Flat Head - SS	X10042	2	M4x10mm
23	Safety Guard Spring Lock Fixture	X80J42	1	
23A	Screw, Hex Head - SS	X80J41	2	M4x12mm
24	Safety Guard Spring Lock W/Hardware	X80J39	1	
24A	Safety Guard Spring Lock	-	1	
24B	Washer, Flat	-	1	M3
24C	Screw, Pan Head	X80J40	2	M3x8mm
25	Gasket	X80J44	1	
26	Cover, Internal Planetary Gear	X80J45	1	
27	Front Interlocking Guard Assy	X80J46/48	1	
27A	Screw, Hex Head - SS	X80J47	8	M5x12mm

*Use after S/N 7810290.

SP80PL MOTOR COMPONENTS

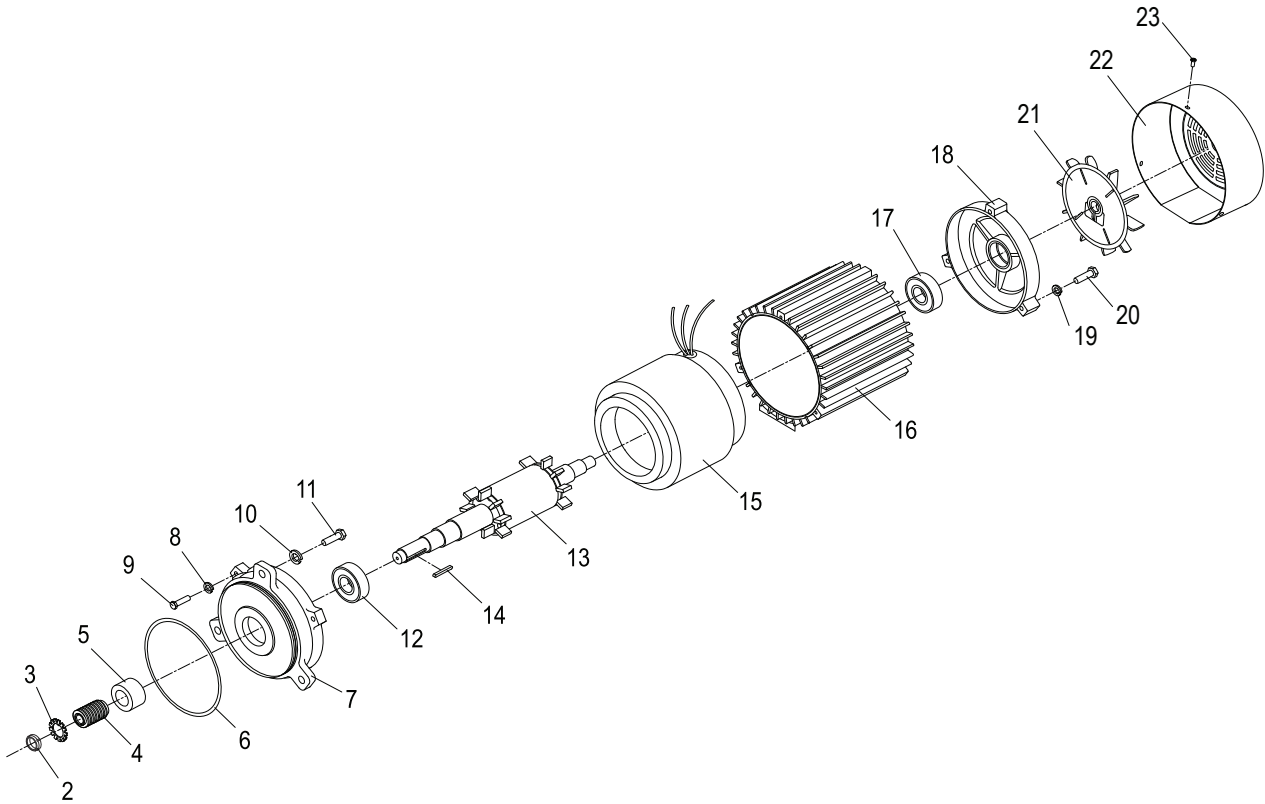

Item	Description	Part Number	Qty	Hardware
1	Motor Assembly, 3Hp 220V	X80G24	1	
	Motor Assembly W/Brake, 3Hp 220V	X80G24C		
	Motor Assembly, 3Hp 380V	X80G1-23		
	Motor Assembly W/Brake, 3Hp 380V	X80G1-23C		
2	Nut, Bearing	X80G01	1	M25
3	Washer, External Tooth	X80G02	1	M25
*4	Worm Drive, 50Hz	X80D39G03	1	
	Worm Drive, 60Hz	X80D39G03-1		
5	Bronze Bushing (Spacer)	X80G04	1	
6	O-Ring	X80G05	1	P73x3
7	Motor Front Cover	-	1	
8	Washer, Split Lock	X80G07	6	M6
9	Screw, Hex Head	X80G06	6	M6x30mm
10	Washer, Split Lock	-	3	M12
11	Screw, Hex Head	-	3	M12x40mm
12	Washer	-	1	
12	Ball Bearing	X40125	1	
13	Motor Shaft	-	1	
14	Shaft Key	-	1	6x6x45mm
15	Motor Coil	-	1	
16	Motor Body	-	1	
17	Ball Bearing	X10012	1	
18	Rear Motor Cover	-	1	
19	Washer, Split Lock	X80G07	3	M6
20	Screw, Hex Head	X80G06	3	M6x20mm
21	Fan	-	1	
22	Fan Cover	-	1	
23	Screw, Pan Head	-	1	M5x12mm

* Included with Worm Gear (Page 10). Worm Drive and Worm Gear must be replaced at same time.

SPC80PL MOTOR BRAKE COMPONENTS

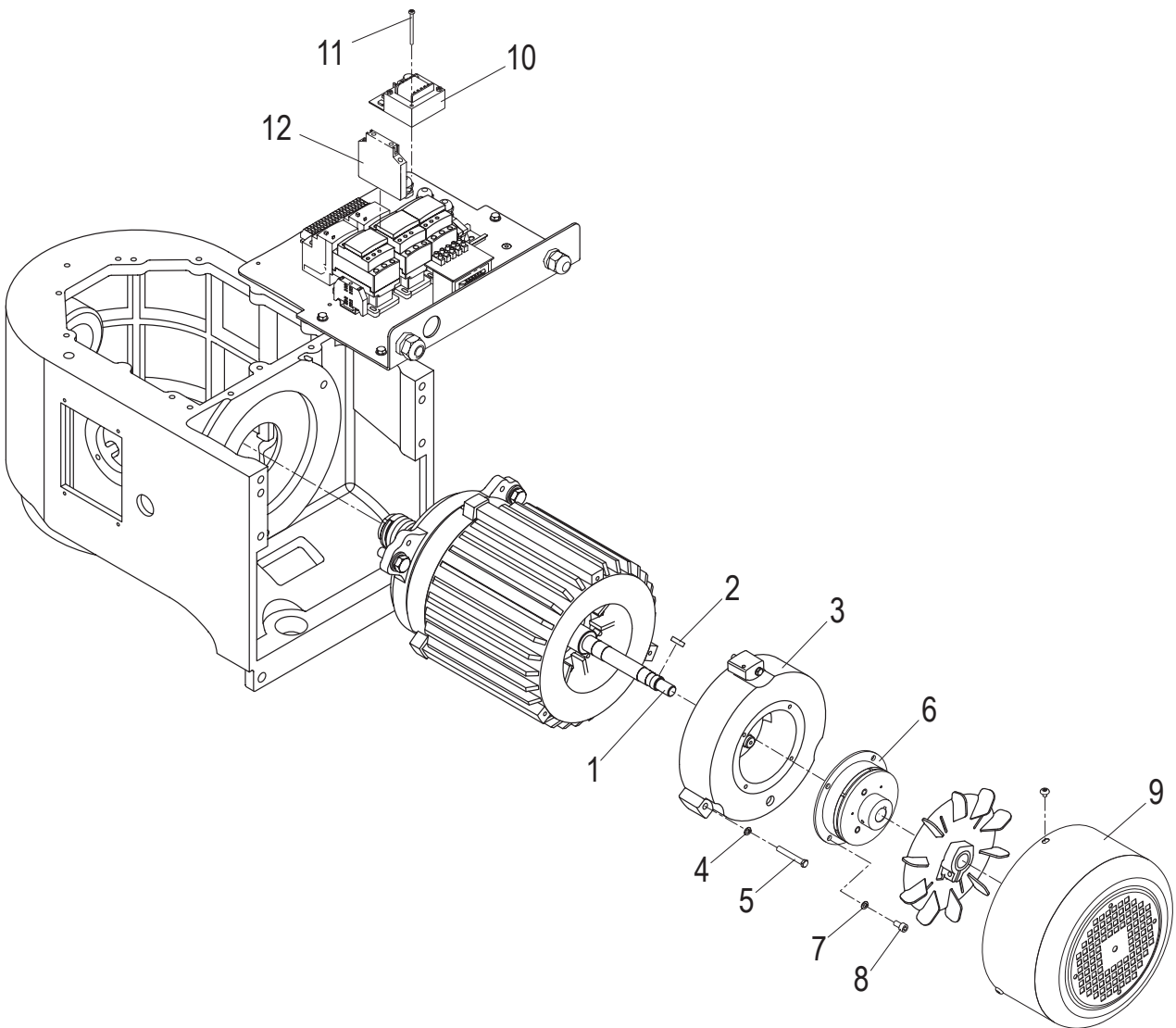

Item	Description	Part Number	Qty	Hardware
*1	Motor Shaft	-	1	
2	Shaft Key	-	1	5x5x20mm
3	Motor Cover, Extended	X80G18-1	1	
4	Washer, Split Lock	-	3	1/4"
5	Screw, Hex Head	-	3	1/4-20 x 1-1/8"
6	Motor Brake, Magnetic	X80G27	1	
7	Washer, Split Lock	-	4	M6
8	Screw, Hex Head	-	4	M6x14mm
9	Fan Cover, Extended	X80G20-1	1	
10	Electronic Board, 220V/380V	X80J11-1	1	
11	Screw, Round Head	-	2	M3x34mm
12	Auxiliary Contact Block	-	1	

*Included With SPC Model Motor Assembly X80G24C & X80G1-23C (Page 15).

SP80PL MANUAL LIFT CONTROLS

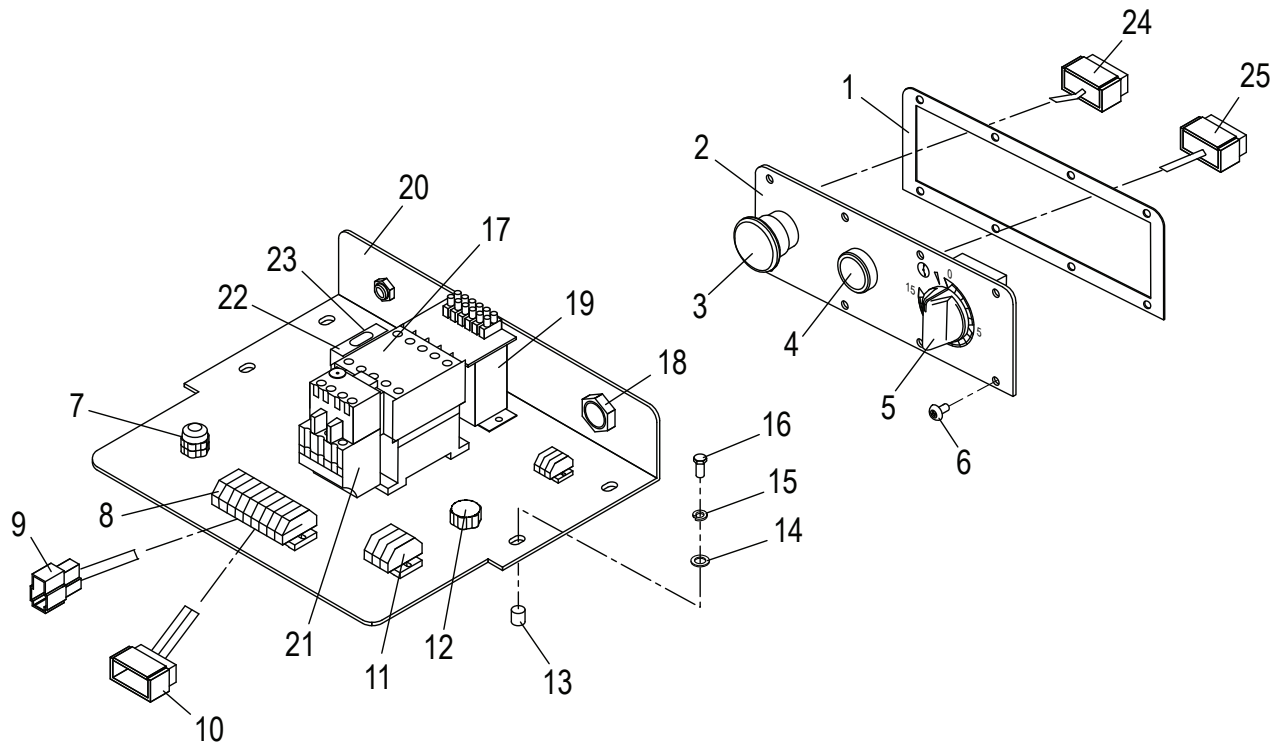

Item	Description	Part Number	Qty	Hardware
1	Gasket	X80J01	1	
2	Control Panel	X80J02	1	
3	Stop Button	X80J03	1	
4	Start Button	X80J04	1	
5	Timer Assembly With Knob	X10137	1	
	Timer Knob	X101037-1	1	
6	Screw, Truss Head	X80J06	8	M4x10mm
7	Support Tube	X80J07	4	
8	Connecting Block Assembly	X80J08	1	
9	Connector	X80J09	1	
10	Connector	X80J10	1	
11	Terminal Block	X80J11	3	
12	Support Tube	X80J12	1	
13	Socket	X80J13	4	
14	Washer, Flat	X80J14	4	M6
15	Washer, Split Lock	X80J15	4	M6
16	Screw, Hex Head	X80J16	4	M6x20mm
17	Contactor, 24V	X80J17	1	
18	Support Tube	X80J18	1	
19	Transformer, 24V (220V Mixer)	X80J19	1	
	Transformer, 24V (380V Mixer)	*9070T50D19		
20	Electronics Mtg Plate	X80J20	1	
21	Overload Relay	X80J21	1	
22	Fuse	X80J22	2	
23	Fuse Fixture	X80J23	3	
24	Connector	X80J24	1	
25	Connector	X80J25	1	

*380V Square D transformer.

SP80PL POWER LIFT CONTROLS

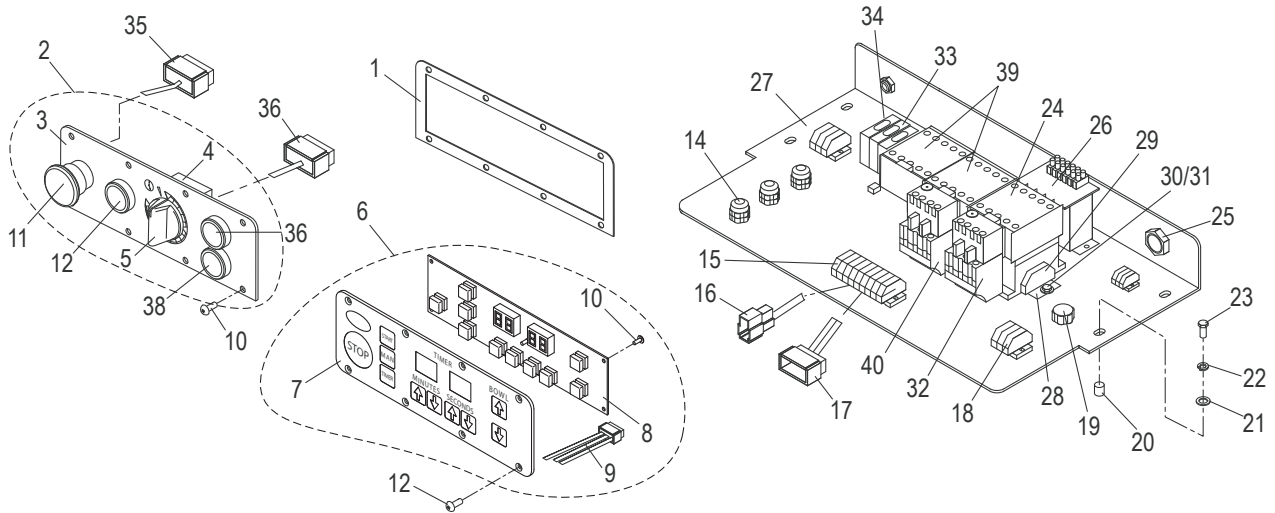

Item	Description	Part Number	Qty	Hardware
1	Gasket	X80J01	1	
2	Faceplate And Timer Assembly	X80J49	1	
3	Control Panel	X80J02	1	
4	Timer Assembly With Knob	X10137	1	
5	Timer Knob	X10137-1	1	
6	Control Panel, Digital - Upgrade Kit	X80J02-1	1	
7	Control Panel, Digital	XB754-1		
8	Circuit Board	X00679	1	
9	Wiring	-	1	
10	Screw, Circuit Board Mounting	-	5	M3 x 10mm
11	Stop Button	X80J03	1	
12	Start Button	X80J04	1	
13	Screw, Truss Head	X30204	8	M4x10mm
14	Support Tube	X80J07	4	
15	Connecting Block	X80J08	1	
16	Connector	X80J09	1	
17	Connector	X80J10	1	
18	Terminal Block	X80J11	3	
19	Support Tube	X80J12	1	
20	Socket	X80J13	4	
21	Washer, Flat	X80J14	4	M6
22	Washer, Split Lock	X80J15	4	M6
23	Screw, Hex Head	X80J16	4	M6x20mm
24	Contactora, 24V	X80J17	1	
25	Support Tube	X80J18	1	
26	Transformer, 24V (220V Mixer)	X80J19	1	
	Transformer, 24V (380V Mixer)	*9070T50D19		
27	Electronics Mtg Plate	X80J20	1	
28	Contactora Mounting Plate	-	1	
29	Contactora Locking Caps	-	2	
30	Screw, Round Head	-	2	M3x16mm
31	Washer, Flat	-	2	M3
32	Overload Relay	X80J21	1	
33	Fuse, 250V 500Ma	X80J22A	2	
	Fuse, 250V 1A	X80J22B	1	
34	Fuse Fixture	X80J23	3	
35	Connector	X80J24	1	
36	Connector	X80J25	1	
37	Bowl Raise Button	X80J26	1	
38	Bowl Lower Button	X80J26	1	
39	Bowl Raise/Lower Contactors, 24V	X00680	2	
40	Bowl Lift Motor Overload Relay	X80J30	1	

*380V Square D transformer. **Use after S/N 7810280.

SP80PL WIRING DIAGRAM, MANUAL LIFT MIXER

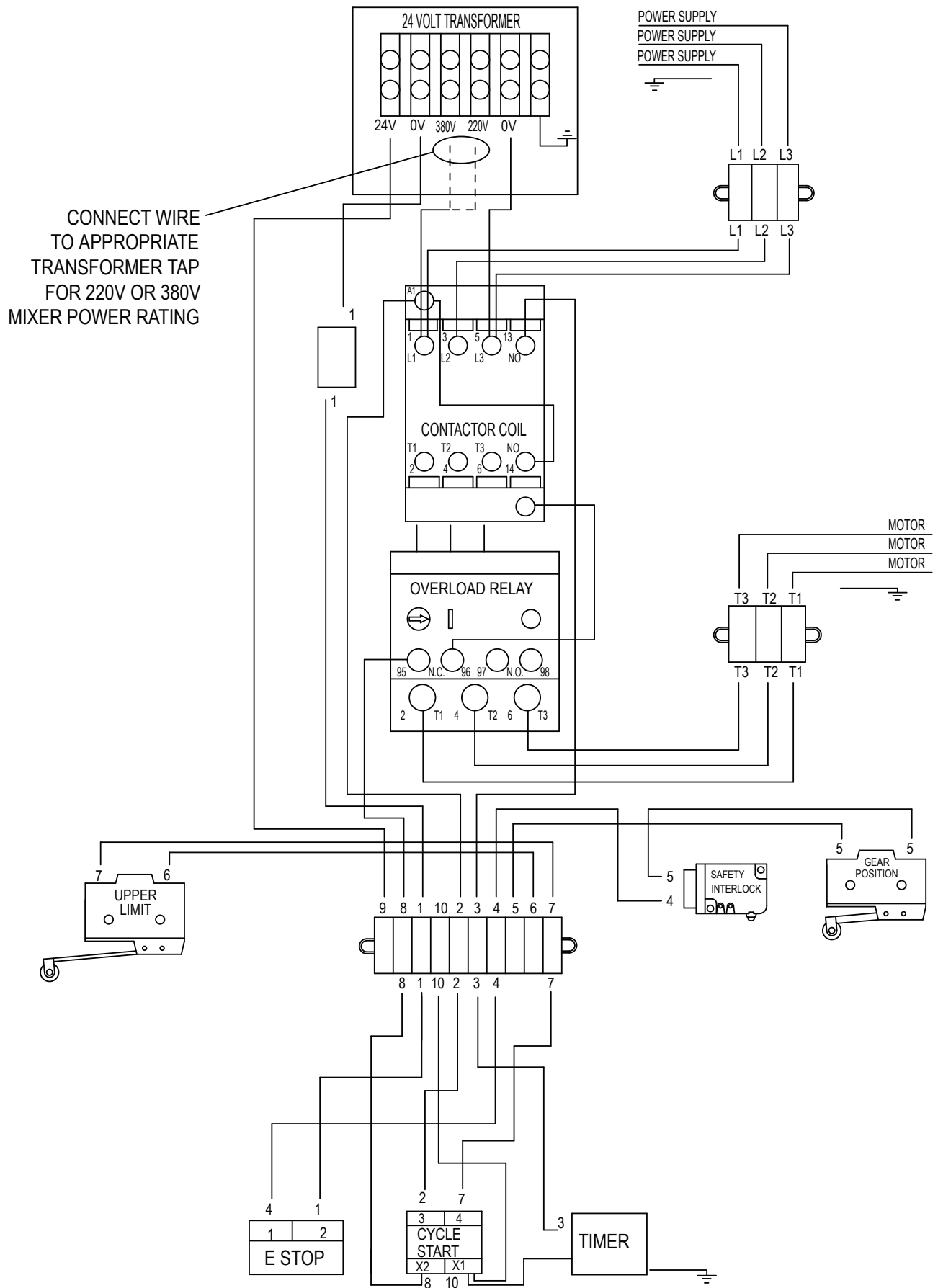

SP80PL WIRING DIAGRAM, POWER LIFT MIXER

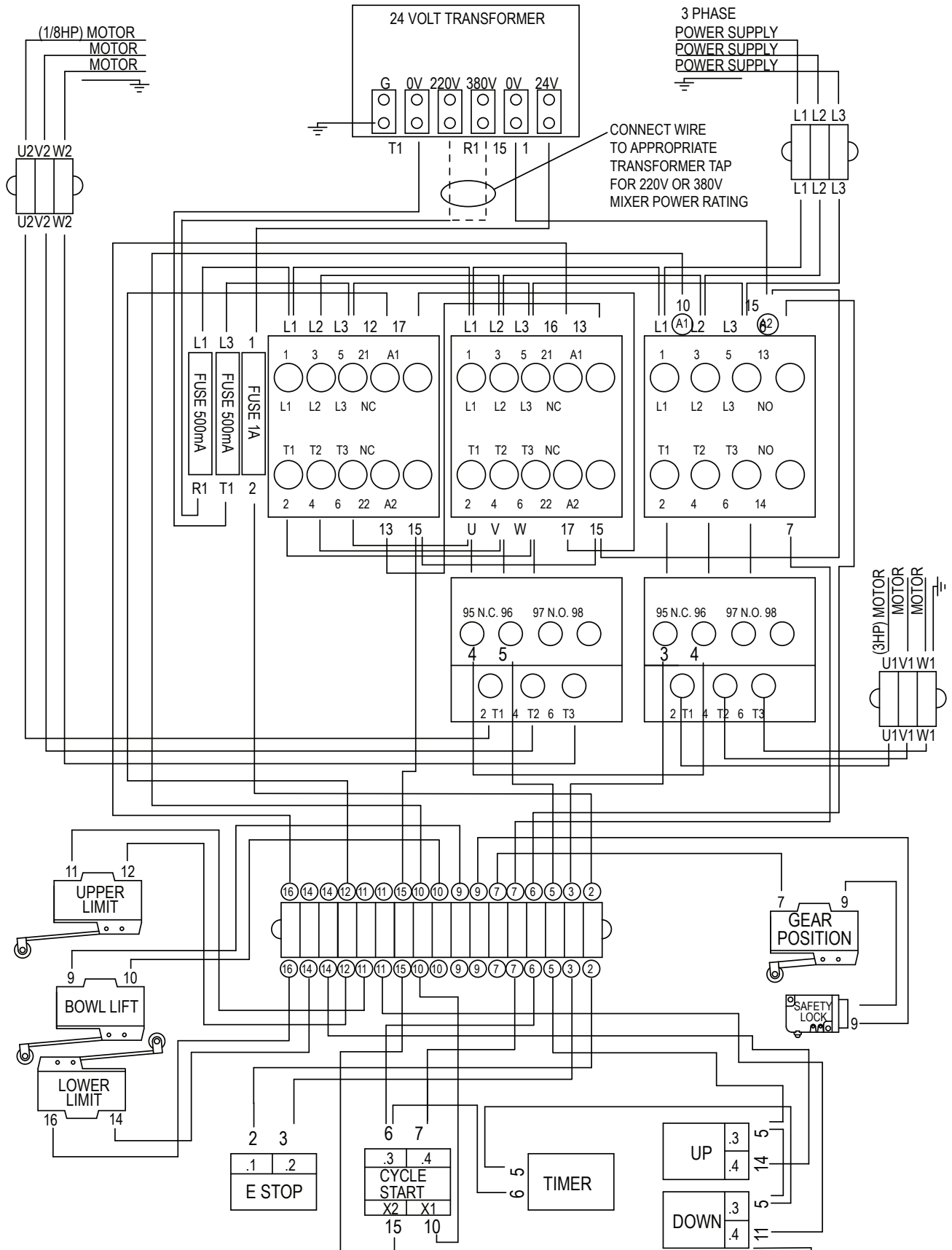

SP80PL 3PH 220V POWER LIFT MIXER SCHEMATIC

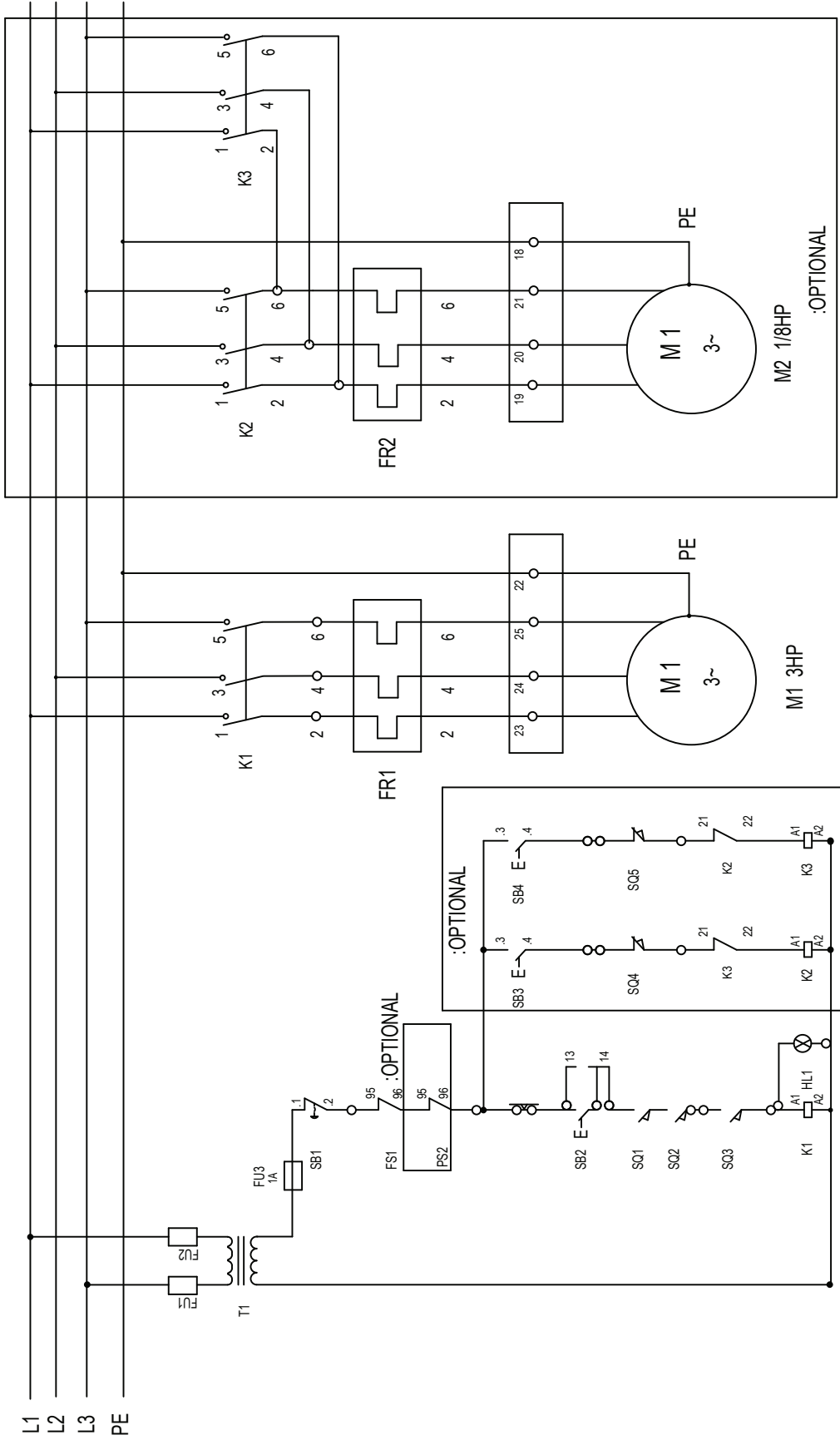

FU4	FUSE FIXTURE + FUSE 1A (5 X 20)
FU5	FUSE FIXTURE + FUSE 1A (5 X 20)
FU6	FUSE FIXTURE + FUSE 1A (5 X 20)
SB1	EMERGENCY STOP BUTTON
SB2	START BUTTON
K1	CONTACT COIL 24VAC
FS1	OVERLOAD RELAY

M1	MOTOR, 3HP, 3PH, 220V OR 380V
KT1	TIMER
SQ1	MICROSWITCH (TRANSMISSION GEAR)
SQ2	MICROSWITCH (INTERLOCK GUARD)
SQ3	MICROSWITCH (BOWL LIFT SAFETY)
SQ4	MICROSWITCH (BOWL LIFT UPPER LIMIT)
SQ5	MICROSWITCH (BOWL LIFT LOWER LIMIT)

SB3	RAISE BUTTON
SB4	LOWER BUTTON
M2	MOTOR, 1/8HP, 3PH, 220V OR 380V
K2	RAISE CONTACTOR COIL, 24VAC
K3	LOWER CONTACTOR COIL, 24VAC
FS2	OVERLOAD RELAY
T1	TRANSFORMER, 24VAC

SPC80PL WIRING DIAGRAM, POWER LIFT MIXER

TRANSFORMER WIRING MAY VARY IN COMPLIANCE WITH MIXER POWER RATING (220V OR 380V)

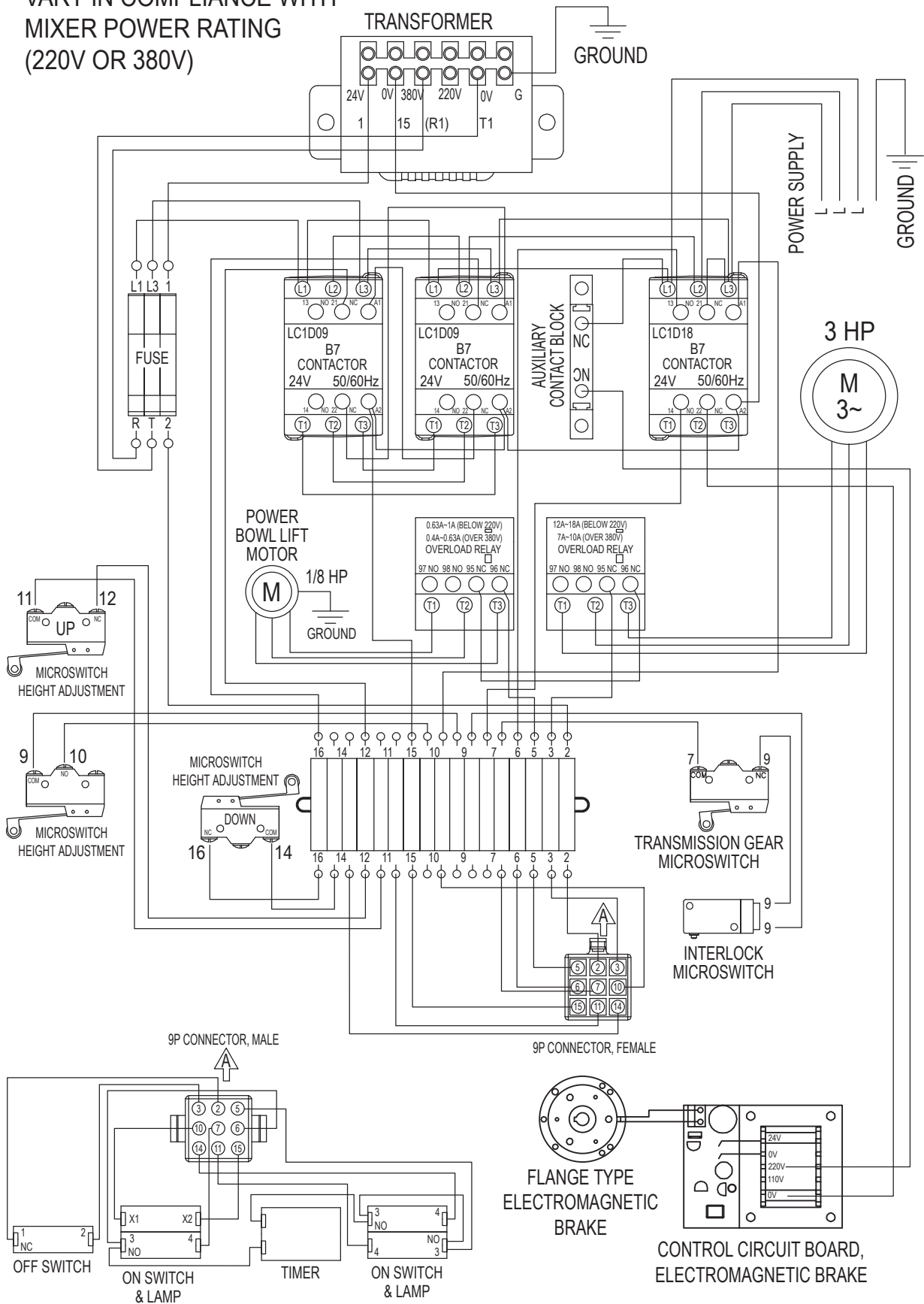

SP80PL WIRING DIAGRAM, POWER LIFT MIXER - DIGITAL CONTROL PANEL

