

Parts Catalog



SP10

MIXERS

MODELS: SP10 & SPC10

09-23-15

IMPORTANT!

TO EXPEDITE SHIPMENT OF PARTS, ALWAYS SPECIFY MODEL, REV,
PART NUMBER, AND SERIAL NUMBER OF MIXER.

GLOBE FOOD EQUIPMENT COMPANY

2215 East River Road

Dayton, Ohio 45439

Parts Department

Toll Free 1-800-745-6238 • Fax (937) 290-0585

E-Mail: info@globefoodequip.com

Website: www.globefoodequip.com

Not for resale

TABLE OF CONTENTS

	Page
Base	1 - 2
Head	3 - 4
Planetary	6
Gears	7-8
Motor	9
Motor Brake - SPC Models Only	10
Manual & Digital Timers	11
SP10 Electrical Diagram - Prior	12
SP10 Wiring Diagram - Prior	13
SPC10 Wiring Diagram - Prior	14
SP/SPC10 Wiring Diagram - Post	15

SP10/SPC10 BASE COMPONENTS

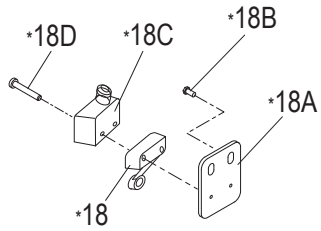

*EXTERNAL ELECTRICAL SYSTEM.
PRIOR TO S/N 7110226

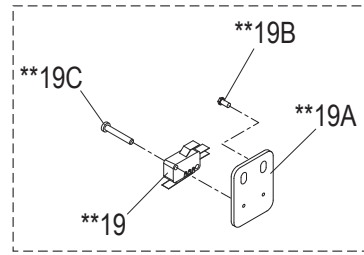

**INTERNAL ELECTRICAL SYSTEM
STARTING WITH S/N 7110226.
MOTOR BRAKE MODELS (SPC)
USE ALTERNATE SWITCH

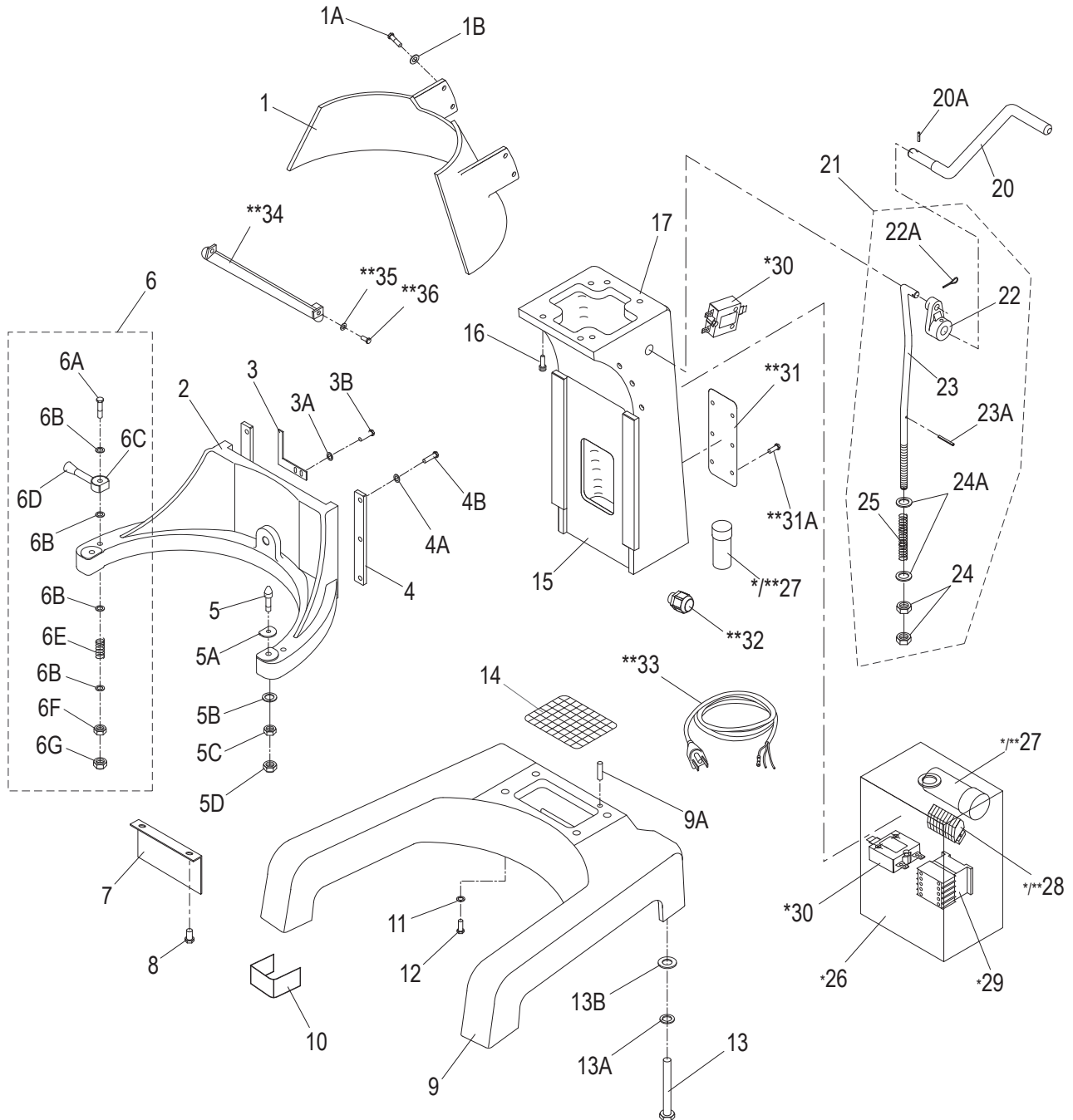

SP10/SPC10 BASE PARTS LIST

Item	Description	Part Number	Qty	Hardware
1	Rear Guard	X10023	1	
1A	Screw, Hex Head	X25097	4	M6x14mm
1B	Washer, Flat	X25069	4	M6
2	Bowl Cradle	X10021	1	
		†X10021-DG		
3	Touch Mass	X10190	1	
3A	Washer, Split Lock	-	2	M4
3B	Screw, Hex Head	X80J41	2	M4x12mm
4	Bowl Slide	X10022	2	
4A	Washer, Split Lock	X80H51	6	M6
4B	Screw, Hex Head	X25097	6	M6x14mm
5	Dowel Screw	X10087	2	
5A	D Washer	-	2	
5B	Washer, Split Lock	X08102	2	M8
5C	Nut, Hex	-	2	M8
5D	Nut, Acorn	X10088	2	M8
6	Bowl Clamp Assembly (Set/2)	X10020	1	
6A	Bowl Clamp Screw	-	2	
6B	Washer, Flat	-	8	M8
6C	Bowl Clamp (Set/2)	X10020-1	1	
6D	Bowl Clamp Handle	-	2	
6E	Spring	-	2	
6F	Nut, Hex	-	2	M8
6G	Nut, Acorn	-	2	M8
7	Cover, Cradle	-	1	
8	Screw, Hex Head	X20185	2	M6x8mm
		X10024		
9	Mixer Base	†X10024-DG	1	
9A	Dowel Pin	-	2	Ø8x15mm
10	Front/Rear Rubber Feet (Set/4)	X10136	4	
11	Washer, Flat	-	4	M10
12	Screw, Hex Head	-	4	M10x40mm
13	Screw, Hex Head	X10025	4	M10x50mm
13A	Washer, Split Lock	X80B02	4	M10
13B	Washer, Flat	X10034	4	M10
14	Screen	X10031	1	
15	Mixer Column, Old Style	*X10035	1	
	Mixer Column, New Style	**X10035-1		
		†X10035-1-DG		
16	Cap Screw, Socket Head	-	4	M8x25mm
17	Label, Hazardous Voltage (Not Shown)	X91014	1	
*18	Microswitch, Bowl Interlock (Raise/Lower)	X30219	1	
*18A	Bracket	-	1	
*18B	Screw, Hex Head - Bracket Mounting	X20185	2	M6x8mm
*18C	Cover, Microswitch	X10084	1	
*18D	Screw, Round Head - Switch Mounting	-	2	M5x10mm
**19	Microswitch, Bowl Interlock (Raise/Lower)	X10085-1	1	
	Microswitch, Bowl Interlock - SPC (Raise/Lwr)	X10085-2		
**19A	Bracket	-	1	
**19B	Screw, Hex Head - Bracket Mounting	X20185	2	M6x8mm
**19C	Screw, Round Head - Switch Mounting	-	2	M5x10mm
20	Bowl Lift Arm	X10040	1	
20A	Dowel Pin	X10039	1	Ø5x30mm
21	Bowl Lift Arm Assembly	X10037A	1	
22	Bowl Lift Cam	X10038	1	
22A	Cotter Pin	-	1	-
23	Bowl Lift Rod	-	1	
23A	Roll Pin	X10036	1	Ø3x28mm
24	Nut, Hex	X10032	2	M10
24A	Washer, Flat	X10034	2	M10
25	Spring	X10033	1	
*26	Electrical Box	X10030	1	
*/**27	Capacitor, Start - 200MF	X10026	1	
**28	Connecting Block Set	X10029A	1	
	Connecting Block, 2C Gry	X10029-2G	7	
	Connecting Block End Cap	X10029-EC	1	
*29	Contact	X10028	1	
30	Circuit Breaker (Old Style, E-T-A Series)	X10027-1	1	
	Circuit Breaker (New Style, 74 Series)	X10027-2	1	
**31	Cover Plate	X10191	1	
**31A	Screw, Truss Head	-	4	M5x6mm
**32	Strain Relief	-	1	
**33	Power Cord And Plug	-	1	
**34	Front Guard, Mixer Column	X10184	1	
**35	Flat Washer	-	2	M6
**36	Screw, Hex Head	X20185	2	M6x8mm

*External Electrical system (Prior to S/N 7110226). **Internal Electrical System (Starting S/N 7110226). †Use after S/N (7111033)

SP10SPC10 HEAD COMPONENTS

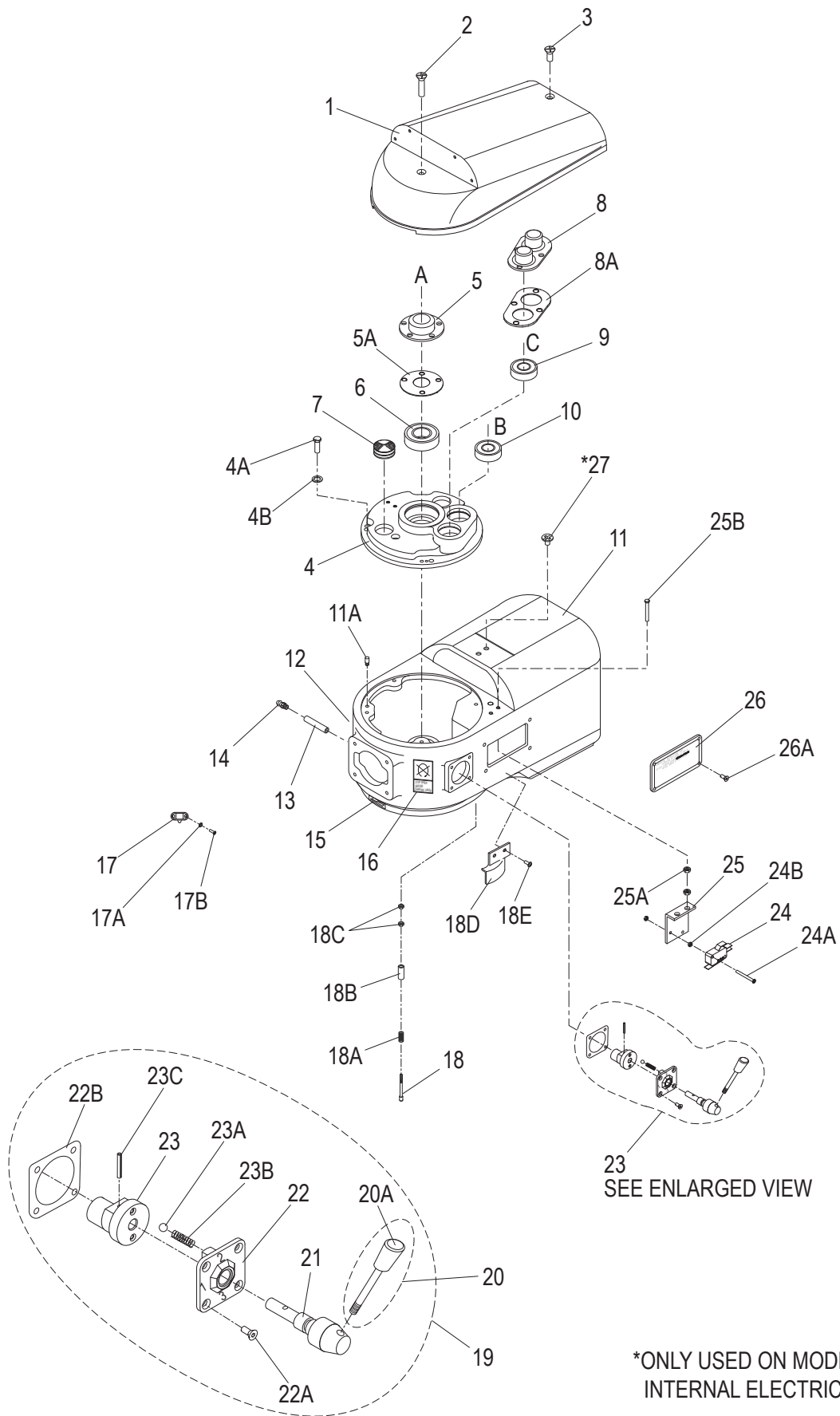

SP10/SPC10 HEAD PARTS LIST

Item	Description	Part Number	Qty	Hardware
1	Transmission Cover-Side Controls	X10001-1	1	
	Transmission Cover-Front Controls	X10001-2	1	
		**X10001-2-DG		
2	Screw, Flat Head - Transmission Cover, Front	X10180	1	M6x30mm
3	Screw, Flat Head - Transmission Cover, Rear	X10181	1	M6x15mm
4	Transmission Case Lid	X10074	1	
4A	Screw, Hex Head	-	4	M6x16mm
4B	Washer, Split Lock	-	4	M6
5	Bearing Retainer Cap	X10072	1	
5A	Gasket, Bearing Retainer	X10187	1	
6	Ball Bearing	X10010	1	
7	Grease Plug	X10073	1	
8	Twin Bearing Retainer	X10071	1	
8A	Gasket, Twin Bearing Retainer	X10188	1	
9	Ball Bearing	X10068	1	
10	Ball Bearing	X10068	1	
11	Case, Transmission - Fixed Bowl Guard	X10059	1	
	Case, Transmission - Removable Bowl Guard	X10059-1		
11A	Locating Pin	-	2	Æ8xM6x10mm
12	Label, Lubricate	X91009	1	
13	Grease Tube	X10217	1	
14	Grease Fitting	X10900	1	
15	Label, Arrow	X91012	1	
16	Label, Stop To Change Gears	X91010	1	
17	Safety Guard Spring Lock	X10134	1	
17A	Washer, Split Lock	X10134A	2	M3
17B	Screw, Round Head	X10134B	2	M3x8mm
18	Touch Shaft, Brass (Prior To S/N 7110208)	X10043	1	
	Touch Shaft, Nylon (Start With S/N 7110208)	X10043N	1	
18A	Spring	X10044	1	
18B	Tube	-	1	
18C	Nut, Hex	-	2	M5
18D	Cover, Touch Shaft (Removable Bowl Guard)	X20516	1	
18E	Screw, Truss Head	-	2	M5x8mm
19	Gear Shift Lever Assembly	X10045-48	1	
20	Gear Shift Lever Assy With Knob	X10045	1	
20A	Knob, Gear Shift	X10045-1	1	
21	Shaft	-	1	
22	Cover	-	1	
22A	Screw, Flat Head	-	4	M5x20mm
22B	Gasket	X10199	1	
23	Shaft, Bias	-	1	
23A	Roller	-	2	
23B	Spring	-	2	
23C	Roll Pin	-	1	Æ3x28mm
24	Microswitch, Bowl Guard Interlock	X10057	1	
	Microswitch, Bowl Guard Interlock - SPC	X10057-1		
24A	Screw, Switch Mounting	-	2	M3x12mm
24B	Nut, Hex	-	4	M3
25	Bracket, Microswitch	X10058	1	
25A	Nut, Hex	-	4	M6
25B	Screw, Hex Head - Bracket Mounting	-	2	M6x40mm
26	Plate, Warning	X10055	1	
26A	Screw, Pan Head	-	4	M4x6mm
*27	Screw, Flat Head	X10131	1	

*Only used on models with internal electrical system (Starting S/N 7110226). **Use after S/N (7111033)

SP10/SPC10 HUB ASSEMBLY COMPONENTS

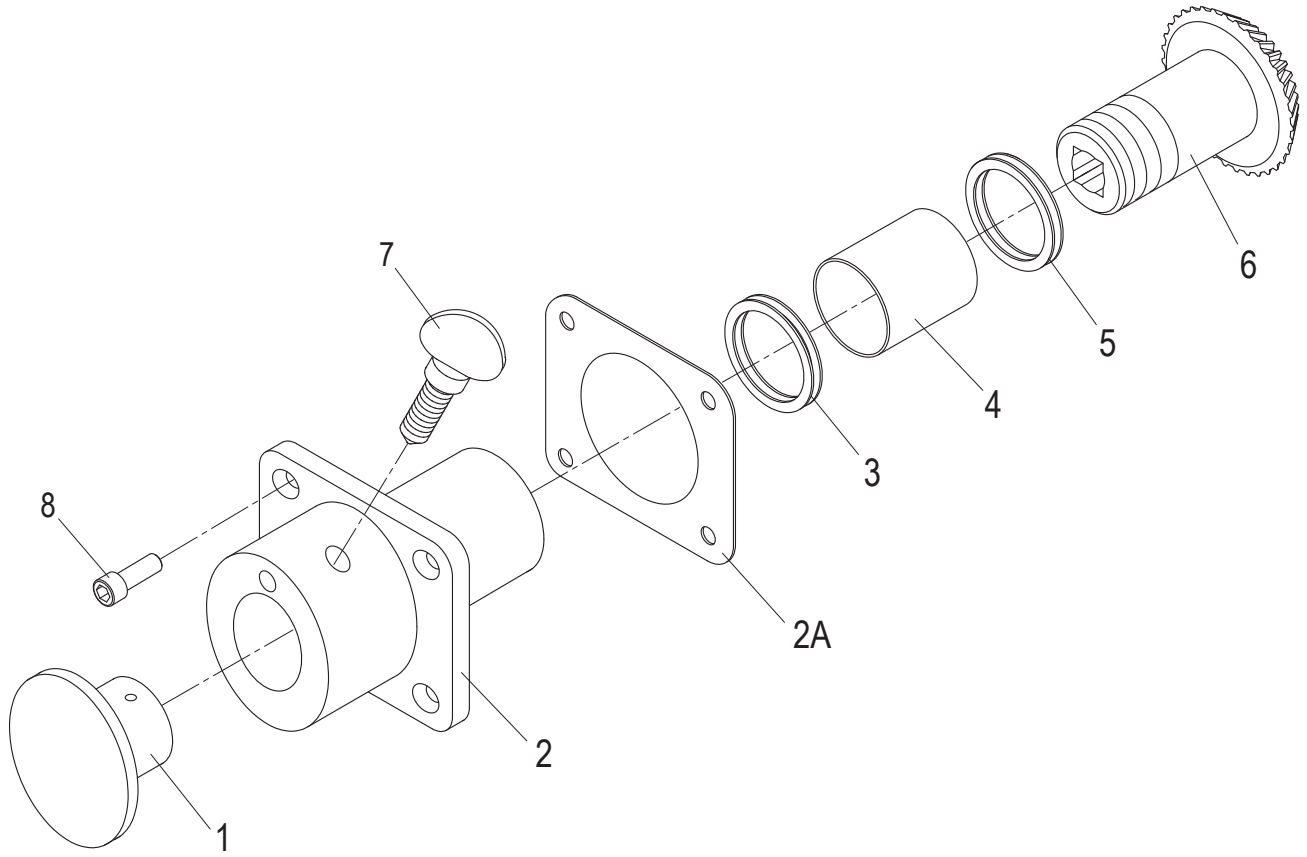

Item	Description	Part Number	Qty	Hardware
1	Attachment Hole Plug	X10007	1	
2	Attachment Hub (Includes X10089 & X10075)	X10006 *X10006-DG	1	
2A	Gasket	-	1	
3	Oil Seal	X10089	1	45x35x8mm
4	Bearing	X10075	1	
5	Thrust Washer	X10004	2	
6	Level Drive Gear (35T)	X10003	1	
7	Thumb Screw	X10005	1	1/2-13x3/4"
8	Screw, Socket Head	-	4	M6x25mm

*Use after S/N 7111033

SP10/SPC10 PLANETARY COMPONENTS

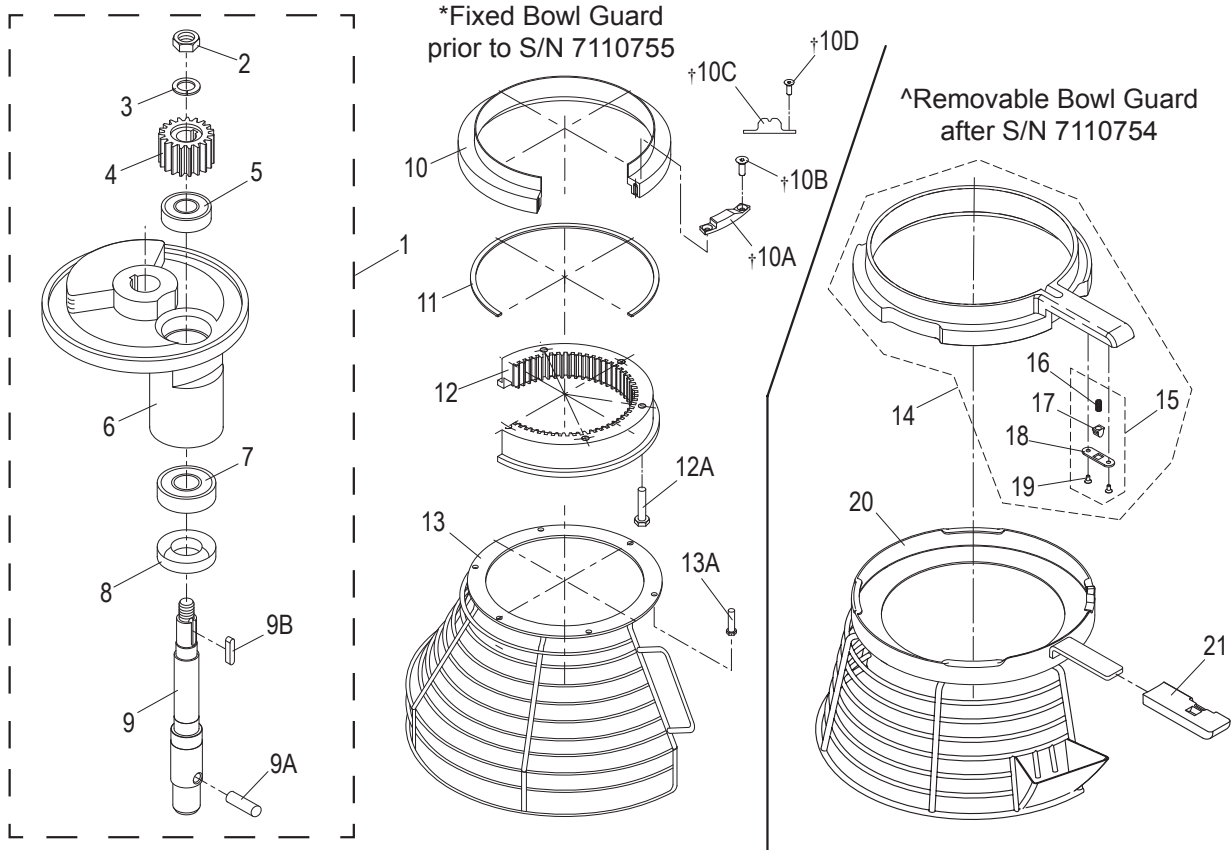

Item	Description	Part Number	Qty	Hardware
1	Complete Planetary Assembly	X10008-82	1	
2	Nut, Hex	X10008	1	M12
3	Washer, Split Lock	X80B05	1	M12
4	Pinion, Beater (19T)	X10009	1	
5	Ball Bearing	X10010	1	
6	Planetary Holder	X10011 **X10011-DG	1	
7	Ball Bearing	X10012	1	
8	Oil Seal	X10013	1	
9	Planetary Shaft	X10015	1	
9A	Dowel Pin	X10080	1	
9B	Shaft Key	X10014	1	5x5x20mm
10	Slide Sheath (Prior To S/N 7110208)	X10076	1	
	Slide Sheath, Molded (Start With S/N 7110208)	X10076P		
†10A	Touch Mass	X10041	1	
†10B	Screw, Flat Head - Ss	X10042	2	M4x10mm
†10C	Safety Guard Spring Lock Fixture	X10135	1	
†10D	Screw, Round Head	-	2	M4x10mm
11	Gasket	X10077	1	
12	Planetary Internal Gear (63T)	X10078	1	
12A	Screw, Socket Head	X10082	6	1/4-20 X 1.25"
13	Front Interlock Guard Assembly	X10079/81	1	
13A	Screw, Hex Head - Locking Patch	X10083	6	M5x8mm
14	Plastic Slide Sheath, Removable Safety Guard	X200S2	1	
15	Spring Plunger Hardware Kit	X200S3	1	
16	Spring	-	1	-
17	Plunger	-	1	-
18	Plate, Plunger Retention	-	1	-
19	Screw, Flat Head	-	2	M3x8mm
20	Bowl Guard Assembly, Stainless Steel	X100S1	1	
21	Handle, Plastic - Removable Safety Guard	X20504	1	

* Prior to S/N 7110755
 ^ After S/N 7110754

†Used with old style (metal) Slide Sheath (X10076). **Use after S/N (7111033).

SP10/SPC10 GEARBOX COMPONENTS

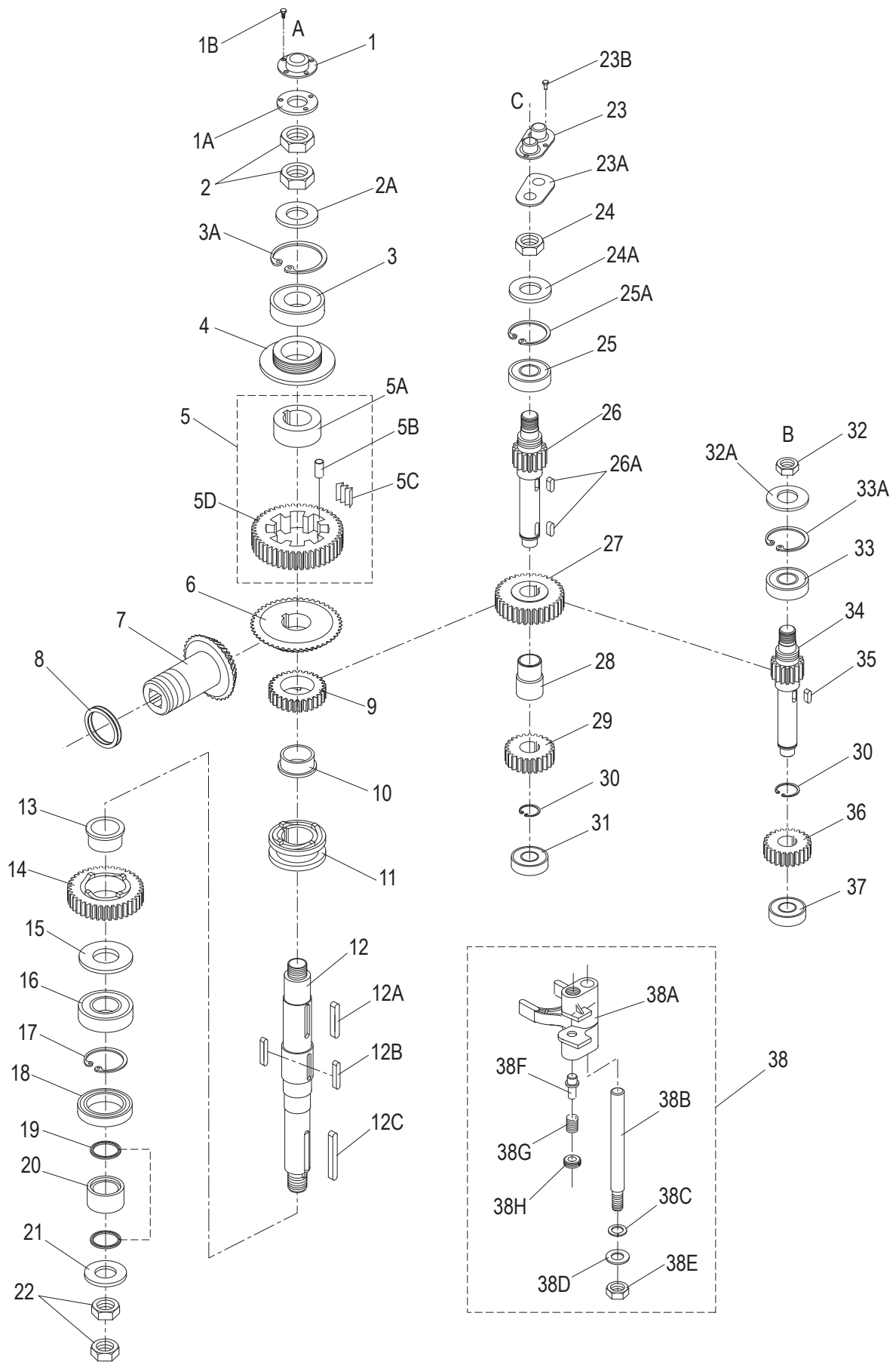

SP10/SPC10 GEARBOX PARTS LIST

Item	Description	Part Number	Qty	Hardware
1	Cap, Bearing Retainer	X10072	1	
1A	Gasket	X10187	1	
1B	Screw, Pan Head	X10133	4	M8x10mm
2	Nut, Jam	X10132	2	1/2-20
2A	Washer, Flat	-	1	1/2"
3	Ball Bearing	X10010	1	
3A	Retaining Ring	-	1	
4	Lead-In Oil Pad	X10090	1	
5	Slow Speed Gear Assembly	X10091-94	1	
5A	Bushing	X10091	1	
5B	Dowel Pin	-	1	
5C	Slice Spring	X10093	1	
5D	Gear, Slow Speed (46T)	-	1	
6	Gear, Bevel (46T)	X10095	1	
7	Level Drive Gear (35T)	X10003	1	
8	Thrust Washer	X10004	1	
9	Gear, Clutch (29T)	X10096	1	
10	Bushing, Clutch	X10099	1	
11	Sleeve, Clutch	X10110	1	
12	Drive Shaft	X10107	1	
12A	Shaft Key	X10098	1	6x6x27mm
12B	Shaft Key	X10109	1	5x5x27mm
12C	Shaft Key	X10108	1	6x6x45mm
13	Bushing, Clutch	X10099	1	
14	Gear, Clutch (38T)	X10100	1	
15	Washer, Stepped	X10101	1	
16	Ball Bearing	X10102	1	
17	Retaining Ring	-	1	RTW-52
18	Oil Seal	X10105	1	
19	O-Ring	X10103	2	28x22x3mm
20	Guard, Oil Bushing	X10104	1	
21	Washer, Flat	-	1	M20
22	Nut, Jam	X10106	2	M20
23	Bearing Retainer, Twin	X10071	1	
23A	Gasket	X10188	1	
23B	Screw, Truss Head	X10131	4	#10-24x3/8"
24	Nut, Hex	X10130	1	3/8"
24A	Washer, Flat	-	1	3/8"
25	Ball Bearing	X10068	1	#35
25A	Retaining Ring	-	1	
26	Transmission Shaft (15T)	X10129	1	
26A	Shaft Key	X10128	2	5x5x10mm
27	Gear (32T)	X10126	1	
28	Bushing, Spacer	X10122	1	
29	Gear (24T)	X10121	1	
30	Retaining Ring	X10120	2	STW-19
31	Ball Bearing	X10117	1	
32	Nut, Hex	X10125	1	M10
32A	Washer, Flat	X10034	1	M10
33	Ball Bearing	X10068	1	
33A	Retaining Ring	-	1	
34	Shaft, Master (15T)	X10124	1	
35	Shaft Key	X10123	1	5x5x15mm
36	Worm Wheel (24T)	X10118-24T	1	
	Worm Wheel (29T)	X10118	1	
37	Ball Bearing	X10117	1	
38	Yoke Shifter Assembly	X10111-116	1	
38A	Yoke, Shifter	-	1	
38B	Guide, Rod Shifter	-	1	
38C	Washer, Split Lock	-	1	3/8"
38D	Washer, Flat	-	1	3/8"
38E	Nut, Stop	-	1	3/8-16
38F	Plunger, Yoke Shifter	-	1	
38G	Spring, Retainer	-	1	
38H	Spring, Yoke Shifter	-	1	

SP10/SPC10 MOTOR COMPONENTS

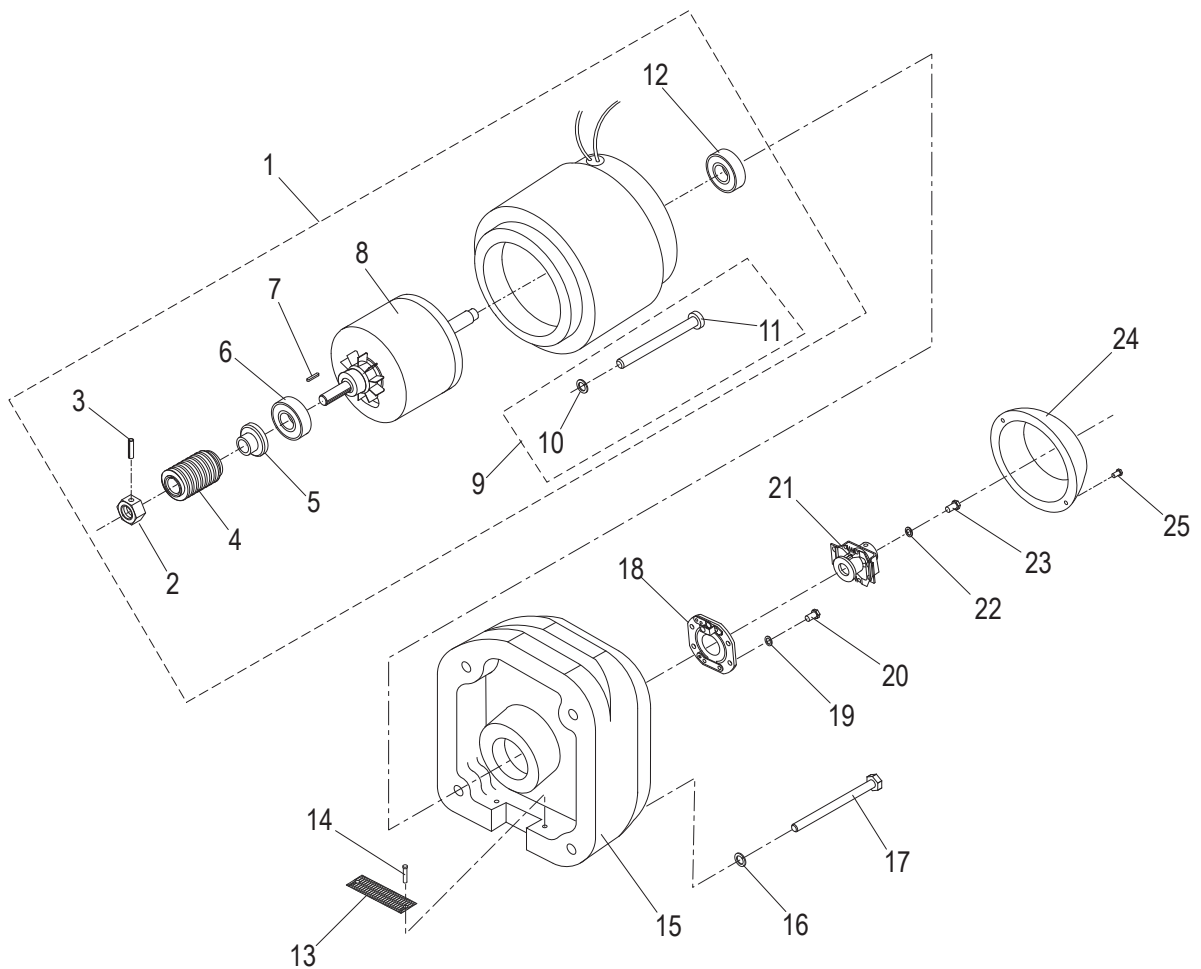

Item	Description	Part Number	Qty	Hardware
1	Motor Assembly, 1/3 HP	X10060-67	1	
	Motor Assembly, 1/3 HP - Motor Brake	X10060-67C		
2	Nut, Hex - Pinned	X20066	1	M8
3	Roll Pin	-	1	M3x16mm
4	Worm (5T)	X20065	1	
5	Spring Shock Absorber	X20060	1	
6	Ball Bearing	X08114	1	
7	Shaft Key	X20202	1	3x3x17mm
8	Motor Shaft	-	1	
	Motor Coil	-	1	
9	Screw And Lock Washer Set	X20206-207	1	
10	Washer, Split Lock	X20207	4	M5
11	Screw, Hex Head	X20206	4	M5x84mm
12	Ball Bearing	X08114	1	
13	Screen	X20031	1	
14	Rivet	-	2	
15	Transmission Cover, Rear	X10054	1	
16	Washer, Split Lock	1226	4	M6
17	Screw, Hex Head	X20161	4	M6x35mm
18	Switch, Platinum	X10051	1	
19	Washer, Split Lock	X20207	2	M5
20	Screw, Hex Head	-	2	M5x10mm
21	Clutch	X10052	1	
22	Washer, Split Lock	X20207	1	M5
23	Screw, Hex Head	-	1	M5x10mm
24	Cover	X10053	1	
25	Screw, Hex Head	-	2	M5x10mm

SPC10 MOTOR BRAKE COMPONENTS

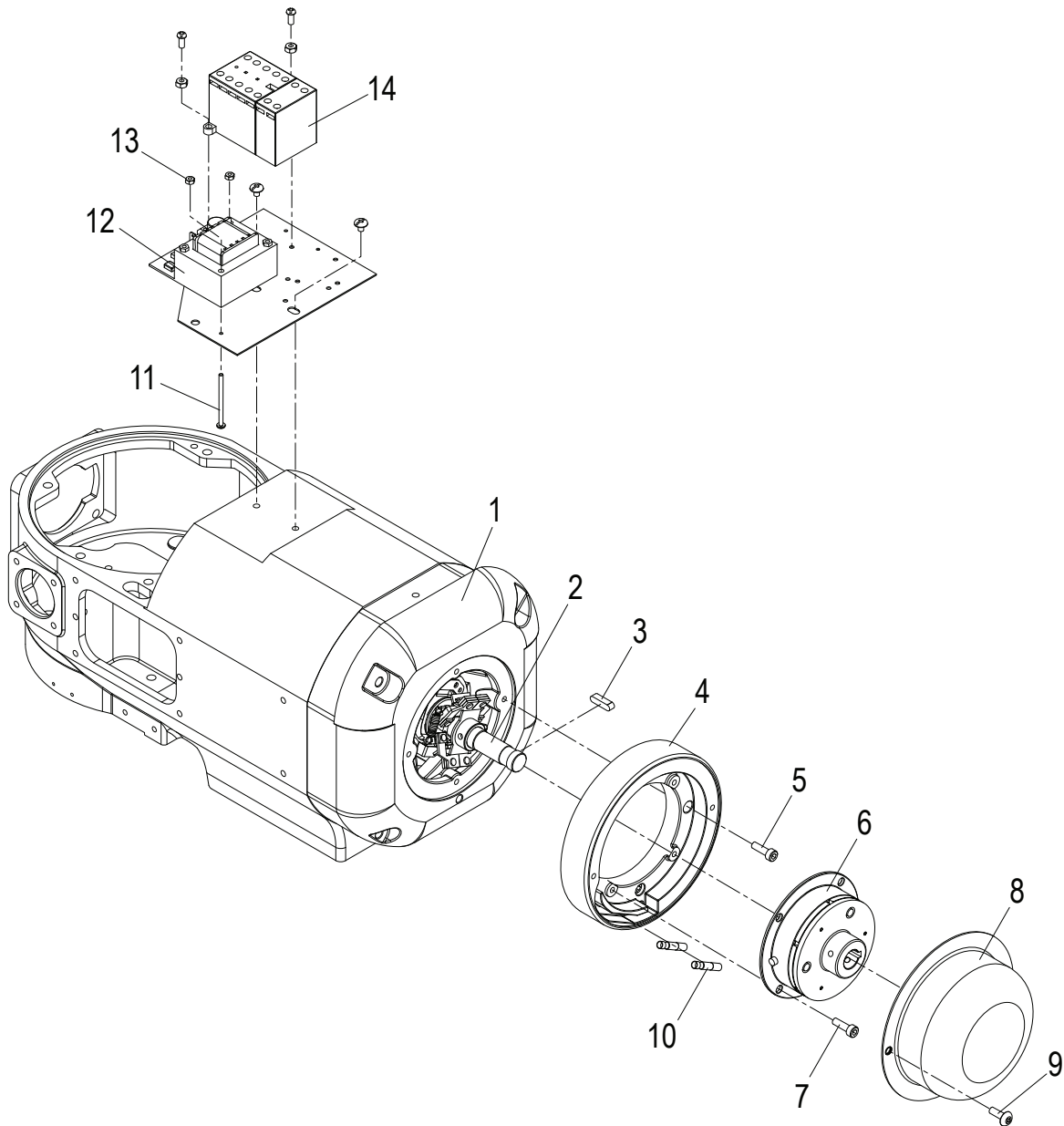

Item	Description	Part Number	Qty	Hardware
1	Motor Cover, Rear - Mtr Brake	X20054-1	1	
2	Motor Shaft	-	1	-
3	Shaft Key	-	1	5x5x20mm
4	Housing, Brake	X20509	1	
5	Screw, Socket Head	-	4	3/16"
6	Magnetic Brake	X20511	1	
7	Screw, Socket Head	X80F16	4	M5x12mm
8	Cover, Magnetic Brake	X20510	1	
9	Screw, Button Head	-	2	M5x10mm
10	Connector	-	2	-
11	Screw, Round Head	-	2	M3x34mm
12	Electronic Circuit Board, 110V	X20512	1	
13	Nut, Hex	-	2	M3
14	Auxiliary Contact Block	X20513	1	

SP10/SPC10 MANUAL LIFT CONTROLS

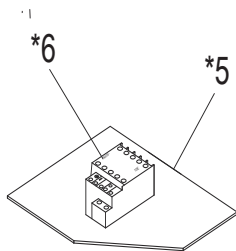
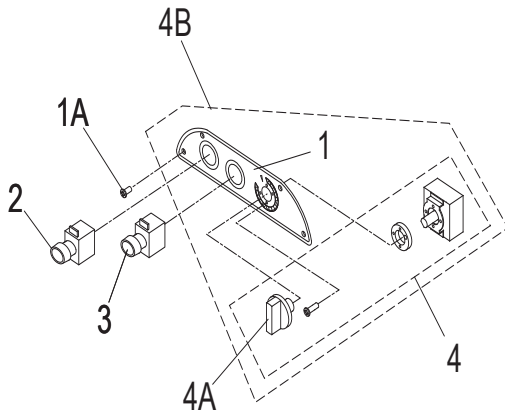

*ONLY USED ON MODELS WITH
INTERNAL ELECTRICAL SYSTEM.

MANUAL TIMER

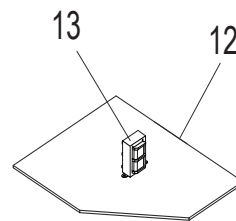
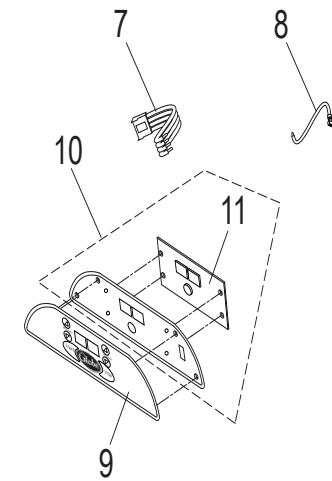

DIGITAL TIMER

Item	Description	Part Number	Qty	Hardware
1	Control Panel	X10002	1	
1A	Screw, Truss Head - Control Panel Mounting	X10179	4	M4x10mm
2	Emergency Stop Button	X10050	1	
3	Start Button	X10049	1	
3A	Boot, Start/Stop Switch Button (Not Shown)	X10049-1	2	
4	Timer Assembly With Knob	X10137	1	
4A	Timer Knob	X10137-1	1	
4B	Timer Assy W/Control Panel (X10137 & X10002)	X10296	1	
*5	Contactor Mounting Plate	-	1	
*6	Contactor, 16V, 600VAC	X10028ABB	1	
7	4 Wire Harness W/Connector	X00675	1	
8	Single Wire W/Quick Connect	X00676	2	
9	Switch, Membrane	X00565	1	
10	Control Panel Assembly	X00562	1	
11	Control Board	X00568	1	
12	Mounting Plate	-		
13	Control Transformer Assembly	X00569	1	
14	Control Transformer Fuse (Not Shown)	X00570	1	

SP10 ELECTRICAL DIAGRAM - 120V SINGLE PHASE - PRIOR

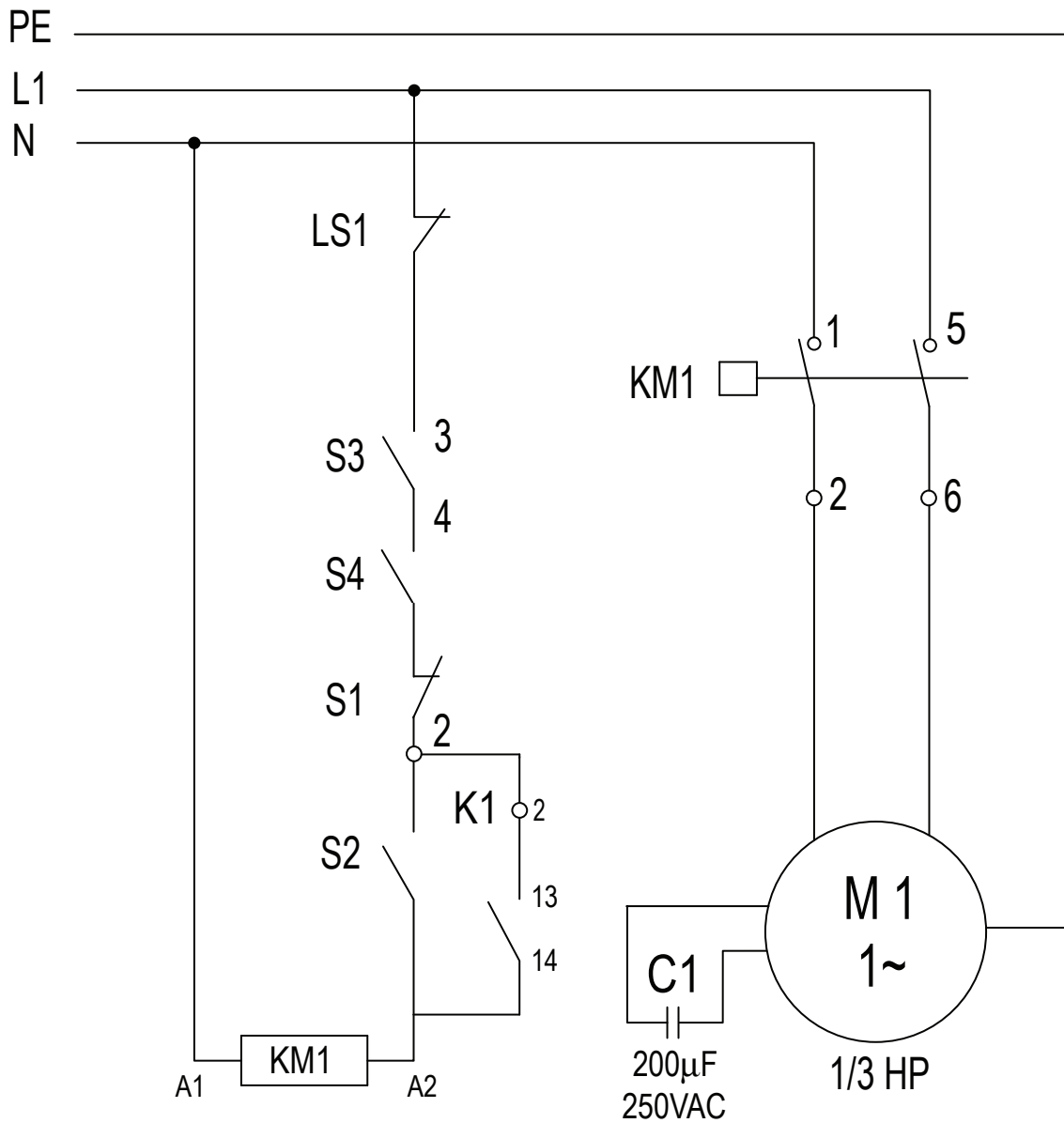

Item	Description	Qty
C1	Capacitor	1
S1	Emergency Stop Button	1
S2	Start Button	1
S3	Microswitch (Interlock Guard)	1
S4	Microswitch (Bowl Lift)	1
KM1	Contactors Coil, 120V, 60 HZ	1
M1	Motor, 1/2 HP Single Phase 120V	1
LS1	Circuit Breaker	1
K1	Timer	1

SP10 WIRING DIAGRAM - 120V SINGLE PHASE - PRIOR

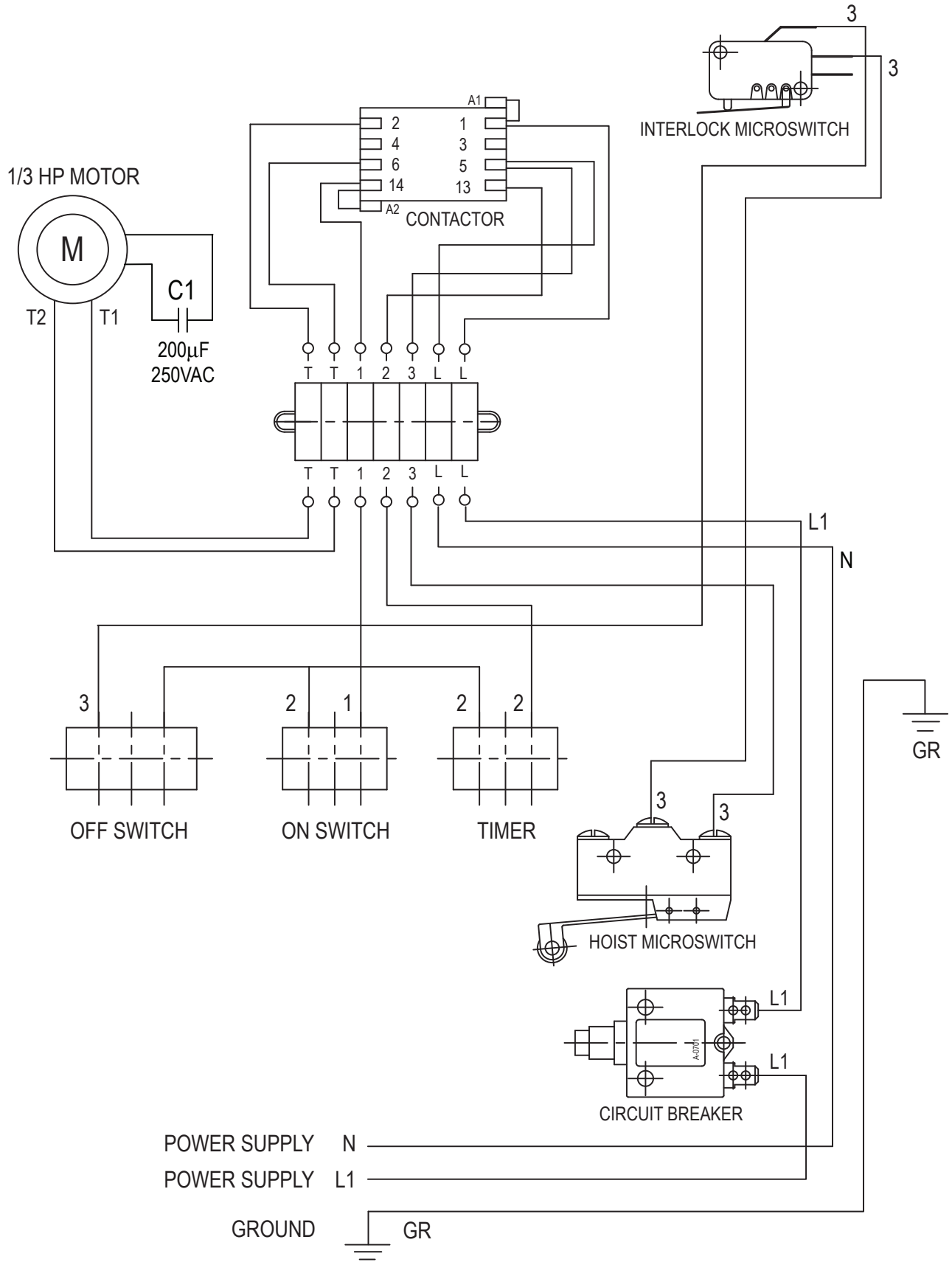

SPC10 WIRING DIAGRAM - 120V SINGLE PHASE - PRIOR

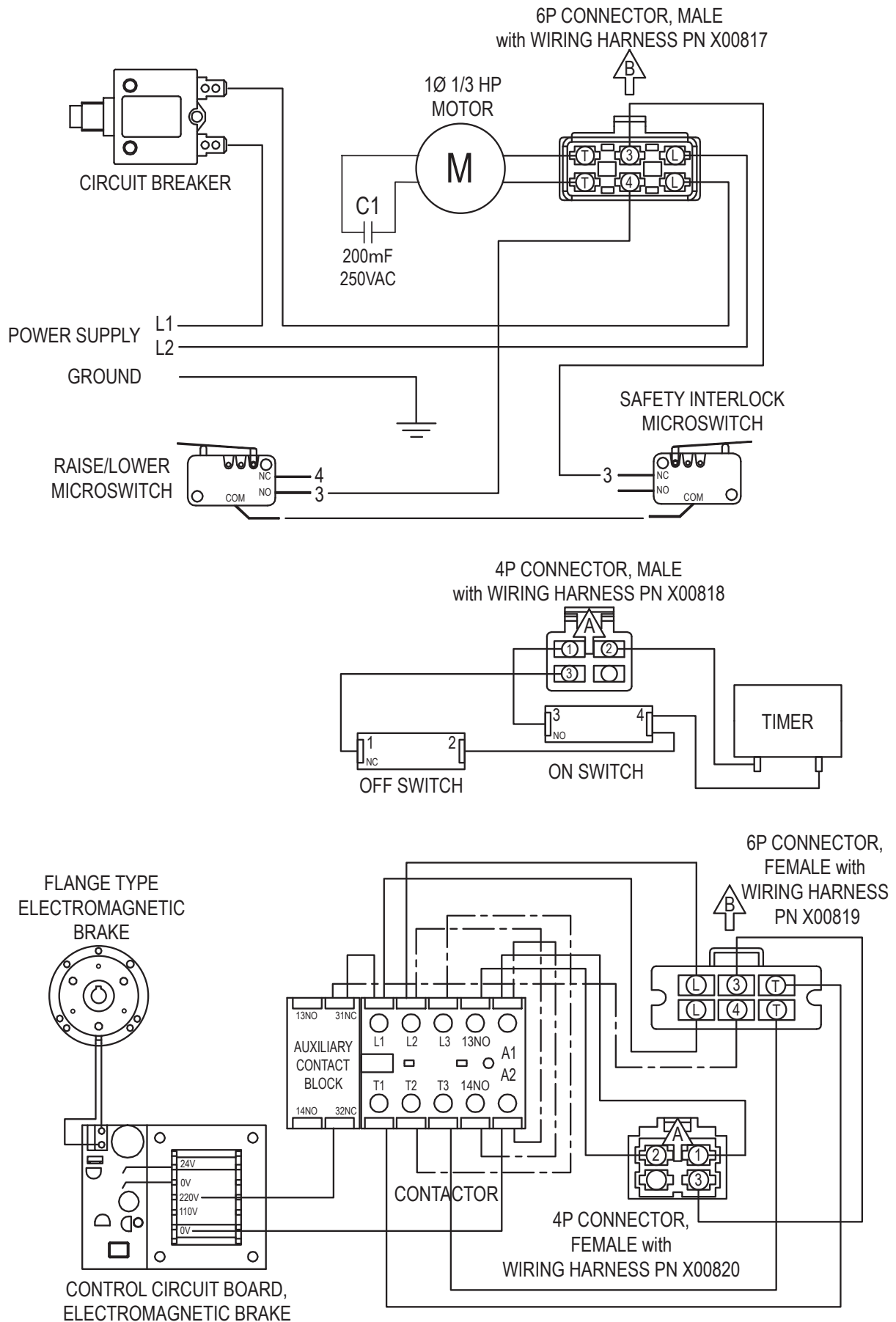

SPC10 WIRING DIAGRAM - 120V SINGLE PHASE - POST

