



Outperform every day.™

ENGLISH

Operator's Manual

HEAVY DUTY CAYENNE® GAS FLAT TOP GRIDDLE



Item	Model	Description	BTU/hr	Gas Type
924GGM	FTG2024	Gas Flat Top Griddle 24"	60,000	Natural Gas or Propane*
936GGM	FTG2036	Gas Flat Top Griddle 36"	90,000	Natural Gas or Propane*
948GGM	FTG2048	Gas Flat Top Griddle 48"	120,000	Natural Gas or Propane*
960GGM	FTG2060	Gas Flat Top Griddle 60"	150,000	Natural Gas or Propane*
972GGM	FTG2072	Gas Flat Top Griddle 72"	180,000	Natural Gas or Propane*

*Shipped setup for Natural Gas and includes a kit for conversion to Propane Gas



Thank you for purchasing this Vollrath equipment. Before operating the equipment, read and familiarize yourself with the following operating and safety instructions. SAVE THESE INSTRUCTIONS FOR FUTURE REFERENCE. Save the original box and packaging. Use this packaging to ship the equipment if repairs are needed.

SAFETY PRECAUTIONS

To ensure safe operation, read the following statements and understand their meaning. Please read carefully.

WARNING

Warning is used to indicate the presence of a hazard that *can* cause *severe* personal injury, death, or substantial property damage if the warning is ignored.

CAUTION

Caution is used to indicate the presence of a hazard that *will* or *can* cause *minor* personal injury or property damage if the caution is ignored.

NOTE

Note is used to notify people of installation, operation, or maintenance information that is important but not hazard-related.

For Your Safety!

These precautions should be followed at all times. Failure to follow these precautions could result in injury to yourself and others.

FUNCTION AND PURPOSE

This equipment is intended to be used for grilling foods in commercial foodservice operations only. It is not intended for household, industrial or laboratory use.

UNPACKING THE EQUIPMENT

When no longer needed, dispose of all packaging and materials in an environmentally responsible manner.

1. Remove all packing material and tape, as well as any protective plastic from the equipment.
2. Use caution and assistance from others in lifting and moving this equipment.
3. Clean any glue residue left over from the plastic or tape.
4. Place the equipment in the desired position and height.
5. Install the four (4) legs (A) and feet (B) onto the equipment. See Figure 1.
6. Before using this equipment it must be cleaned and dried thoroughly.

INITIAL SETUP

NOTE: It is vital that the purchaser of this equipment post in a prominent location instructions to be followed in the event that the user smells gas. This information shall be obtained by consulting the local gas supplier. The purchaser of this equipment must post in a prominent location

WARNING

Read and understand all instructions and warnings before using this equipment. Retain this manual for future reference.

FOR YOUR SAFETY

Do not store or use gasoline or other flammable vapors or liquids in the vicinity of this or any other appliance.

WARNING

Improper installation, adjustment, alteration, service or maintenance can cause property damage, injury or death. Read the installation, operating and maintenance instructions thoroughly before installing or servicing this equipment.

WARNING

FIRE, INJURY or DEATH HAZARD

Have this equipment installed by a qualified installer in accordance with all federal, state and local codes. Failure to install this equipment properly can result in injury or death.

WARNING

FIRE, INJURY or DEATH HAZARD

This appliance must be installed and adjusted by a qualified technician in accordance with all federal, state and local codes. Failure to install, adjust or maintain this equipment properly can result in property damage, injury or death.

WARNING

FIRE HAZARD

Do not install or use without 4" legs. Use of this equipment without legs can cause the appliance to overheat and cause a fire.

WARNING

FIRE, INJURY or DEATH HAZARD

This appliance is for use in non-combustible locations only.

WARNING

FIRE and INJURY OR DEATH HAZARD

Injuries or death can occur if this equipment is not used properly. To reduce risk of injury or death:

- Keep the appliance area free and clear from combustibles
- Do not obstruct the flow of combustion and ventilation air
- Do not spray controls or the outside of the appliance with liquids or cleaning agents
- Let hot appliance cool before cleaning or moving
- The appliance should only be used in a flat, level position
- Do not operate unattended

The installation of this appliance must conform with local codes, or in the absence of local codes, with the National Fuel Gas Code, International Fuel Gas Code, ANSI Z223.1/NFPA 54, or the Natural Gas and Propane Installation Code, CSA B149.1, as applicable.

- The appliance and its individual shutoff valve must be disconnected from the gas supply piping system during any pressure testing of that system at test pressures in excess of ½ psi (3.5 kPa).
- The appliance must be isolated from the gas supply piping system by closing its individual manual shutoff valve during any pressure testing of the gas supply piping system at test pressures equal to or less than ½ psi (3.5 kPa).

Clearance and positioning around the appliance: This appliance must be installed adjacent to non-combustible surfaces only with a minimum spacing of 6" from all sides. This appliance must be a minimum distance of 6" from another appliance. The appliance must have the supplied 4" legs installed and be placed on a non-combustible surface.

Air supply and ventilation: The area in front and around the appliances must be kept clear to avoid any obstruction of the flow of combustion and ventilation air. Adequate clearance must be maintained at all times in front of and at the sides of the appliance for servicing and proper ventilation.

Orifice sizing: Equipment is manufactured for 1000 BTU per cubic feet heat value of natural gas. Installer is responsible for correct orifice sizing. Refer to the International Fuel Gas Code for proper orifice sizing.

Pressure regulator: All commercial cooking equipment must have a pressure regulator on the incoming service line for safe and efficient operation. The regulator provided for this appliance is adaptable for both Natural gas and LP gas. A conversion kit with separate instructions is included explaining this procedure in detail.

Regulator information: ¾" NPT inlet and outlet; factory adjusted for 4" w.c. Natural Gas standard and may be converted by qualified personnel to be used for Propane at 10" w.c.

To gas supply if branch connects to appliance or to appliance if branch connects to gas supply

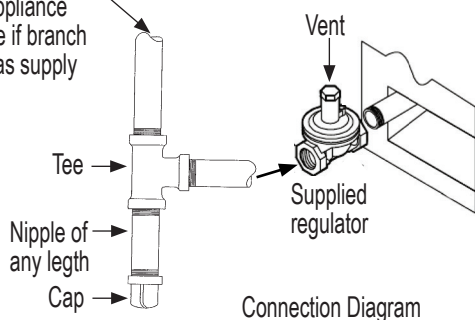

Prior to connecting the regulator, check the incoming line pressure. The regulator can only withstand a maximum pressure of ½ PSI (14" w.c.). If the line pressure is beyond this limit, a step down regulator before the regulator provided will be required. The arrow forged into the bottom of the regulator body shows gas flow direction, and should point downstream to the appliance.

Gas conversion: Conversion from Natural Gas to Liquid Propane (LP) or vice versa may only be performed by a qualified technician or service agent per the International Fuel Gas Code.

NOTE: Refer to the International Fuel Gas Code for proper orifice sizing.

NOTE: The orifice size is marked on the orifice/spud.

Gas connection: The appliance comes fitted with a ¾" N.P.T male adapter for connection to the pressure regulator.

Maintenance: A qualified service company should check the unit for safe and efficient operation on an annual basis. Contact the factory representative or local service company to perform maintenance and repairs.

Gas piping : Gas piping shall be of such size and so installed as to provide a supply of gas sufficient to meet the full gas input of the appliance. If the appliance is to be connected to existing piping, it shall be checked to determine if it has adequate capacity. Joint compound (pipe dope) shall be used sparingly and only on the male threads of the pipe joints. Such compounds must be resistant to the action of LP gases.

CAUTION

Any loose dirt or metal particles, which are allowed to enter the gas lines on this appliance, will damage the valve and affect its operation. When installing this appliance, all pipe and fittings must be free from any internal contaminants. It is recommended that a sediment trap be installed in-line before the regulator.

Manual shut off valve: A manual shut off valve should be installed in an accessible location within 6 ft. (1.8 m) of the appliance.

Checking for gas leaks: Using a gas leak detector or a leak detection solution is recommended for locating gas leaks. Matches, candle flame or other sources of ignition shall not be used for this purpose. Check entire piping system for leaks.

Exhaust canopy: Cooking appliances inherently create a good deal of heat and smoke and should be installed under an efficient exhaust hood with flame proof filters. A vertical distance of not less than 4 ft. (1.2m) shall be provided between the top of the appliance and filters or any other combustible material.

WARNING

FIRE DEATH HAZARD

If you smell gas follow the instructions provided by the gas supplier.

Do not touch any electrical switch; do not try to light the burner; do not use a telephone within close proximity.

Lighting the pilot: The manifold units are equipped with standing pilots, and each should be lit immediately after the gas is supplied to the appliance.

1. Before attempting to light pilots, turn off the main gas valve to the appliance and wait 5 minutes to clear the gas.
2. Turn off all gas control knobs (E). See Figure 1.
3. Turn on control valve and light all pilots.
4. The pilot burner must be lit at the end of the tube. Hold an ignition source through the pilot light hole (D) in the front panel at the pilot tube. When the flame is established remove ignition source.
5. To shut down the appliance turn off the main gas valve to the appliance.

NOTE: Smoke appearing on initial use of the appliance is normal. This is as a result of the rust preventative coating burning off. Allow the appliance to 'burn in' for at least 15 minutes before the first use.

Pilot flame regulation: The pilot flame on the appliance has been factory adjusted. When adjustment is necessary, adjust the pilot flames as small as possible, but high enough to light the burner immediately when burner valve is turned to the 'High' setting. Access to the pilot flame adjustment screw is obtained by removing the front panel.

Burner adjustment: Remove the front panel to gain access. Turn burner valve knob to 'High' position. Slowly decrease mixing ring aperture to give a soft blue flame having luminous tips, then slowly increase opening to a point where the yellow tips disappear and a stable blue flame is obtained.

FEATURES AND CONTROLS



Figure 1. Features and Controls.

- (A) LEG. Supports the equipment.
- (B) ADJUSTABLE FEET. Used to adjust the level of the equipment.
- (C) DRIP TRAY. A tray that collects grease and oil. This tray can be removed for cleaning.
- (D) PILOT LIGHT ACCESS HOLE. Allows access to the pilot light.
- (E) GAS CONTROL KNOB. Used to set or adjust the temperature of the grilling surface.
- (F) GRIDDLE PLATE. Cooking surface.
- (G) KNOB GUARD. Helps protect the control knob from damage.

OPERATION

WARNING

FIRE, INJURY or DEATH HAZARD

Contact a qualified technician or service agent for any adjustments, maintenance or repairs. This appliance is not user serviceable.

WARNING

BURN HAZARD

Hot liquids and steam can burn skin. Never pour any liquid other than oil to be used for cooking on to hot surfaces.

WARNING

FIRE HAZARD

If you smell gas follow the instructions provided by the gas supplier. Do not touch any electrical switch; do not try to light the burner; do not use a telephone within close proximity.

WARNING

BURN HAZARD

Ensure that the griddle plate has cooled down before touching by hand.

Before initial use, turn the gas control knob to the maximum setting, and allow equipment to burn-in for 15 minutes. You will notice smoke appearing due to the cooking surface burning-in. This is normal. After 15 minute burn in period the equipment is ready for use.

To adjust the leveling feet:

1. Hold the leg (A) and rotate the adjustable feet (B) so the equipment is level. See Figure 1.
2. Check the drip tray (C) frequently.
3. To ignite the burners, depress and turn the gas control knob (E) to 'High' position.
4. Allow the appliance to pre-heat before attempting to use.
5. Adjust the valve set-point to obtain the desired level of heat.

CLEANING

To maintain the appearance and increase the service life, clean your equipment daily.

NOTE:

Do not clean the equipment with steel wool.

1. Allow the equipment to cool completely before cleaning.
2. Using a wire brush, scrape the griddle plate (F) to remove any food residue.
3. Using a damp cloth, sponge dipped in soapy water or metal scraper to clean the equipment; rinse and dry thoroughly.
4. Empty and clean the drip tray (C). Place the drip tray (C) into the equipment.

Item	A" (cm)	Burners
924GGM	24" (60.7)	2
936GGM	36" (91.5)	3
948GGM	48" (122.0)	4
960GGM	60" (152.5)	5
972GGM	72" (182.9)	6

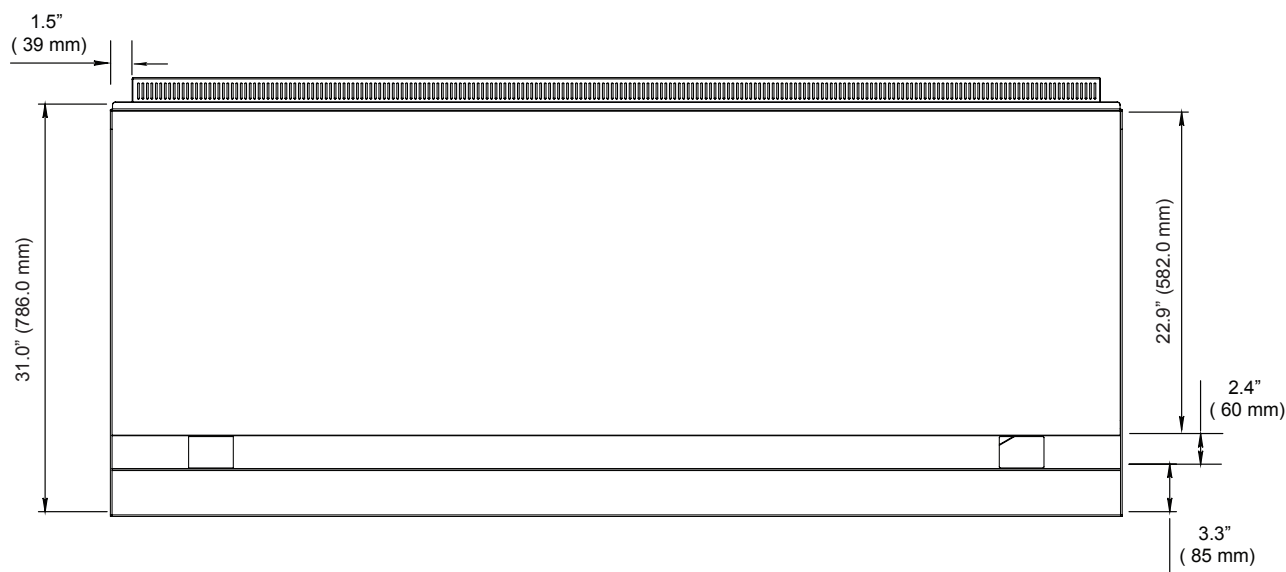
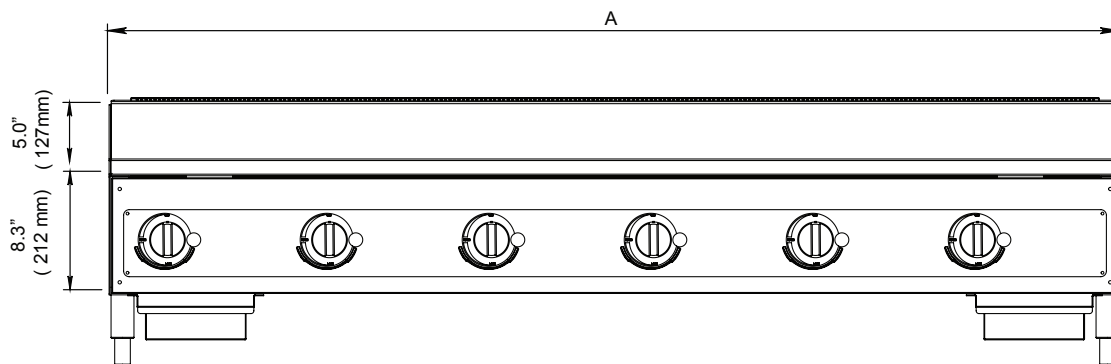
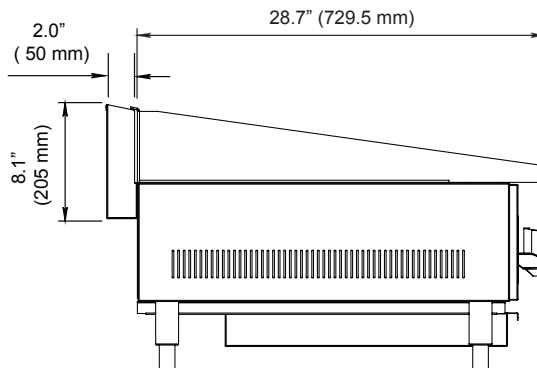

SERVICE AND REPAIR

There are no user serviceable parts within this appliance. To avoid serious injury or damage, never attempt to repair the Griddle yourself. Do not send units directly to the Vollrath Company. Please contact the qualified professional repair service listed below.

VOLLRATH Technical Service • 1-800-628-0832 • Email: techservicereps@vollrathco.com

When contacting the Authorized Professional Service Center, please be ready with the item number, model number (if applicable), serial number, and proof of purchase showing the date the unit was purchased.

WARRANTY STATEMENT FOR THE VOLLRATH Co. L.L.C.

This warranty does not apply to products purchased for personal, family or household use, and The Vollrath Company LLC does not offer a written warranty to purchasers for such uses.

The Vollrath Company LLC warrants the products it manufactures or distributes against defects in materials and workmanship for a period of one year, except as specifically described in our full warranty statement. In all cases, the warranty runs from the date of the end user's original purchase date found on the receipt.

For complete warranty information, product registration and new product announcement, visit www.vollrath.com



www.vollrath.com

The Vollrath Company, L.L.C.
1236 North 18th Street
Sheboygan, WI 53081-3201
U.S.A.

Main Tel: 920.457.4851
Fax: 800.752.5620

Technical Services: 800.628.0832

Canada Service: 800.695.8560

© 2015 The Vollrath Company, L.L.C.

Item No. 2350070-1 en Rev 10/15