



# CATALOG OF REPLACEMENT PARTS

## FD SERIES FOOD WASTE DISPOSERS

**FD4-150**

**FD4-200**

**FD4-300**

**FD4-500**



**Table of Contents**

- 5 DISPOSER (FD4-150, FD4-200, & FD4-300)
- 7 DISPOSER (FD4-500)

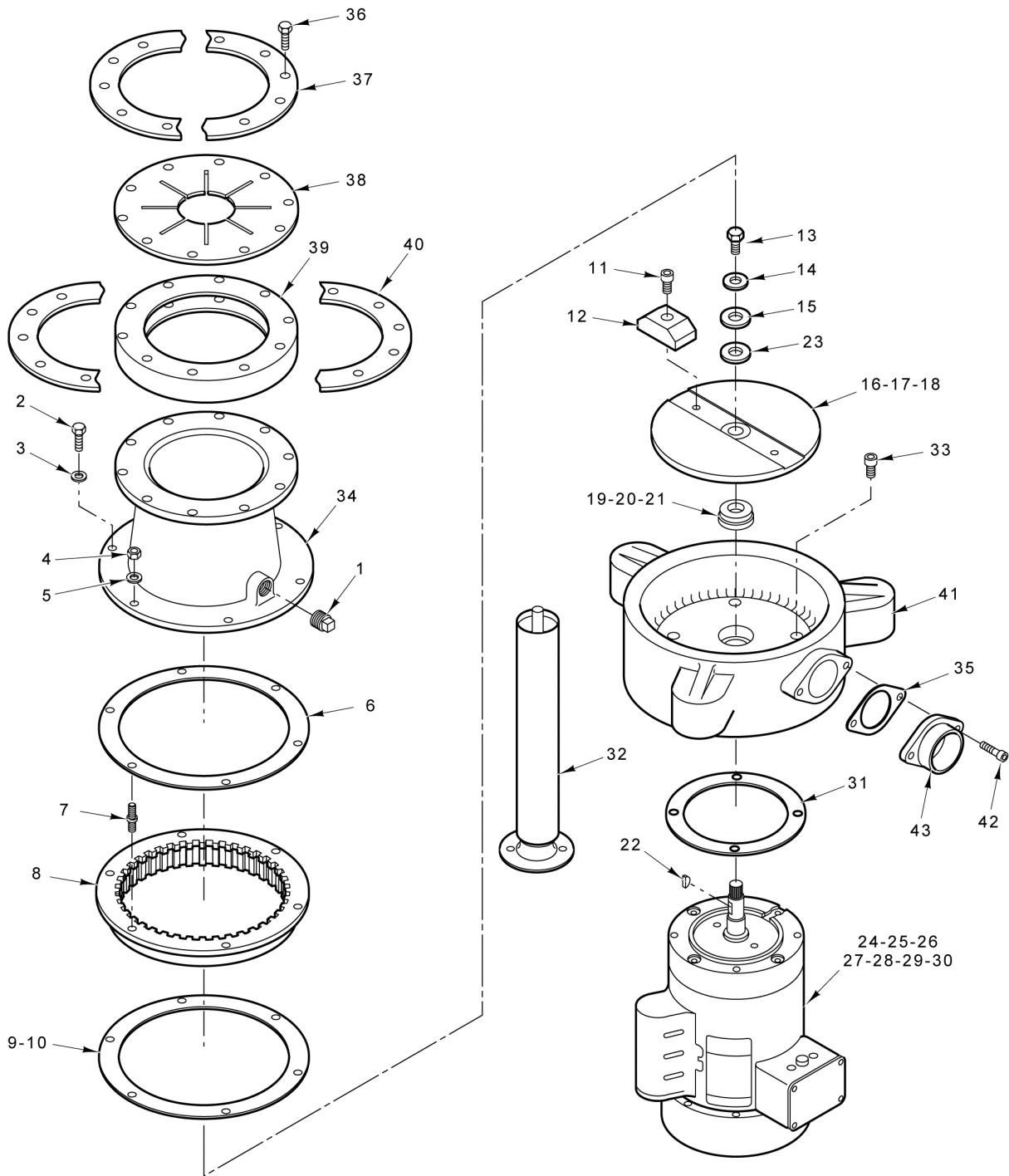

PL-60306

**DISPOSER  
(FD4-150, FD4-200, & FD4-300)**

**DISPOSER  
(FD4-150, FD4-200, & FD4-300)**

ILLUS.	PART NO.	NAME OF PART	AMT.
PL-60306			
1	00-316325	Plug - Pipe 1/2.....	1
2	00-316322	Screw 5/16-18 x 1 Hex Hd. (SST).....	4
3	00-316323	Lockwasher 5/16 Helical.....	4
4	00-316324	Nut 5/16-18 Hex.....	2
5	00-316323	Lockwasher 5/16 Helical.....	2
6	00-316326	Gasket.....	1
7	00-316327	Stud - Centering.....	2
8	00-316328	Ring - Shredder.....	1
9	00-316326	Gasket.....	1
10	00-316355	Kit - Shredder Ring (Incls. Items 4 thru 9).....	1
11	00-316329	Screw 3/8-16 x 3/4 Hex Socket Hd. (SST).....	2
12	00-316330	Block - Cutter.....	2
13	00-316360	Screw 5/16-18 x 3/4 Hex Hd. (SST).....	1
14	00-316323	Lockwasher 5/16 Helical.....	1
15	00-316382	Washer.....	1
16	00-316334	Flywheel.....	1
17	00-316335	Flywheel Assy. (Incls. Items 11, 12, & 16).....	1
18	00-316354	Kit - Flywheel (Incls. Items 11 thru 16 & 23).....	1
19	00-316336	Seal - Cartridge.....	1
20	00-316337	Tool - Install Seal.....	1
21	00-316356	Kit - Cartridge Seal (Incls. Items 19 & 31).....	1
22	00-316363	Key.....	1
23	00-316383	Gasket.....	1
24	00-316375	Motor (1-1/2 Hp.) (115/230 V., 60 Hz., 1 Ph.).....	1
25	00-316376	Motor (1-1/2 Hp.) (110/220 V., 50 Hz., 1 Ph.).....	1
26	00-316377	Motor (1-1/2 Hp.) (208-230/460/60/3; 208/415/50/3).....	1
27	00-316378	Motor (2 Hp.) (115/230 V., 60 Hz., 1 Ph.).....	1
28	00-316379	Motor (2 Hp.) (110/220 V., 50 Hz., 1 Ph.).....	1
29	00-316380	Motor (2 Hp.) (208-230/460/60/3; 208/415/50/3).....	1
30	00-316381	Motor (3 Hp.) (208-230/460/60/3; 208/415/50/3).....	1
31	00-316339	Gasket.....	1
32	00-316395	Leg Assy. - Disposer.....	3
33	00-316329	Screw 3/8-16 x 3/4 Hex Socket Hd. (SST).....	AR
34	00-200942-00001	Housing - Upper.....	1
35	00-316359	Gasket - Flange.....	AR
36	SC-118-16	Cap Screw 1/4-20 x 1-3/8 Hex Hd.....	10
37	00-203185	Ring - Top Cone Clamp (Half).....	2
38	00-202105	Guard - Splash.....	1
39	00-201492	Ring - Isolating.....	1
40	00-203191	Ring - Bottom Cone Clamp (Half).....	2
41	00-316338	Housing - Lower (Incls. Seals).....	1
42	00-316357	Screw.....	AR
43	00-316358	Flange - Drain.....	AR

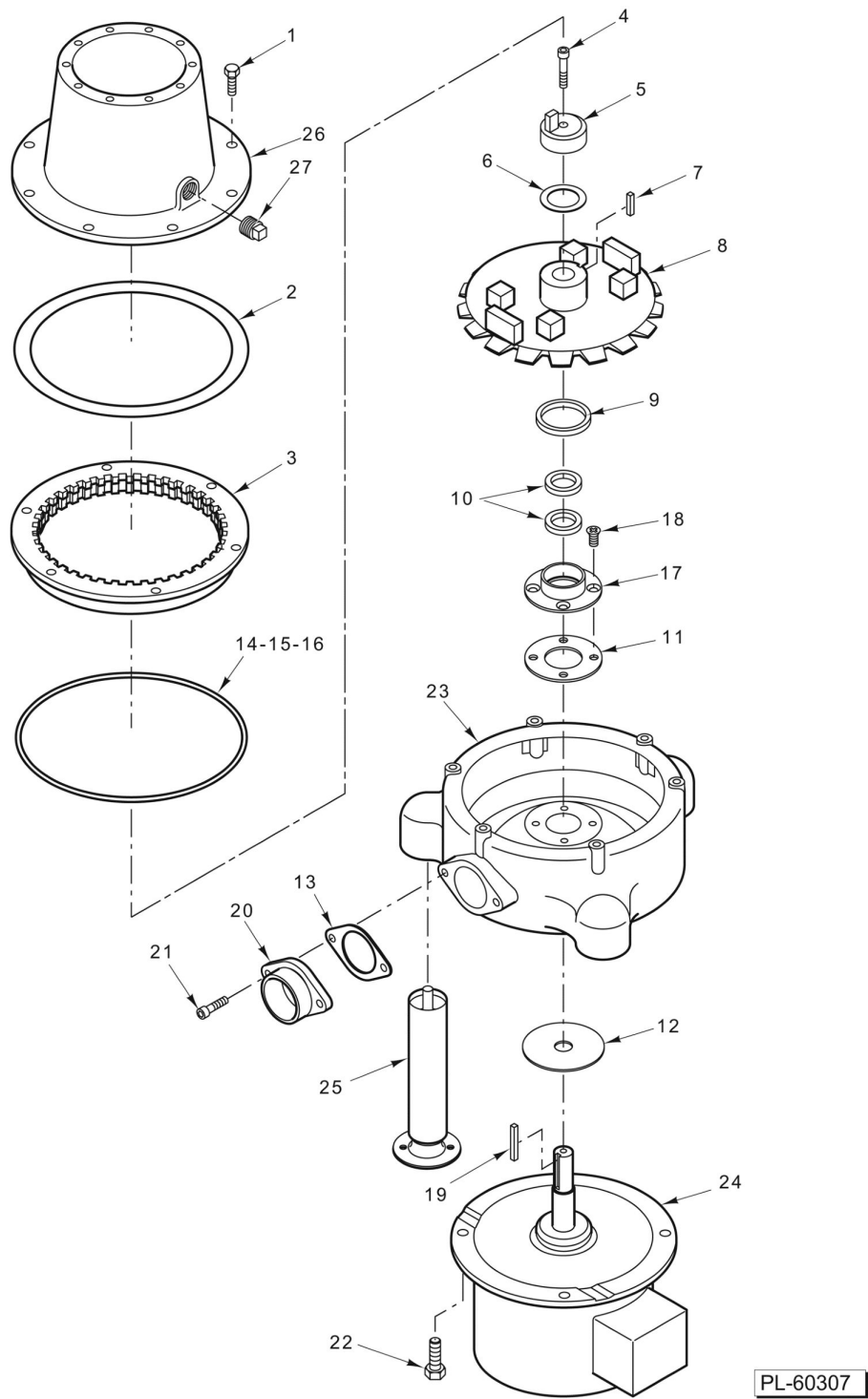

**DISPOSER (FD4-500)**

**DISPOSER (FD4-500)**

ILLUS. PL-60307	PART NO.	NAME OF PART	AMT.
1	00-316295	Screw.....	6
2	00-316296	Gasket.....	1
3	00-316297	Ring - Shredder.....	1
4	00-316299	Screw.....	1
5	00-316300	Bar - Breaker.....	1
6	00-316301	Gasket.....	1
7	00-316302	Pin - Roll.....	1
8	00-316303	Flywheel.....	1
9	00-316304	Seal.....	1
10	00-316305	Seal.....	2
11	00-316306	Gasket.....	1
12	00-316307	Slinger.....	1
13	00-316308	Gasket.....	1
14	00-316298	O-Ring.....	1
15	00-316320	Kit - Seal & Gasket (Incls. Items 2, 6, 9, 10, 11, 13, & 14).....	1
16	00-316321	Kit - Rebuild (Incls. Items 1 thru 14 & Grease).....	1
17	00-316309	Seal - Housing.....	1
18	00-316310	Screw.....	4
19	00-316311	Key.....	1
20	00-316312	Flange - Drain.....	1
21	00-316313	Screw.....	2
22	00-316314	Screw.....	4
23	00-316316	Housing - Lower.....	1
24	00-316374	Motor (5 Hp.).....	1
25	00-316395	Leg Assy. - Disposer.....	3
26	00-200950-00002	Housing - Upper.....	1
27	FP-066-02	Plug 1/2 Sq. Hd. Pipe.....	1

