



BEVERAGE-AIR

Project: _____	AIA#
Item: _____	
Location: _____	SIS#
Approved: _____	

FOOD PREPARATION TABLES

MODEL:
SPE48HC-12M

SPE48HC Sandwich Prep Table With Mega Top Hydrocarbon Series

SPE48HC SANDWICH PREP: MEGA TOP SERIES

3 Year Parts/Labor Warranty
Additional 4 Year Compressor Warranty



CABINET CONSTRUCTION

- Stainless steel front, sides, top, doors and grille (galvanized back & bottom)
- Interior liner is made of corrosion resistant aluminum
- Full electronic control
- Mega top
- Removable hoods made of matching stainless steel
- Self-closing doors with 120° Stay-open feature, on cartridge style hinges
- Easy door removal for service and cleaning
- Field-reversible doors (hinge kit not included)
- Snap-In magnetic gaskets for positive door seal
- Painted aluminum door handles
- 6" Casters, with (2) brakes standard
- 10" Wide cutting board constructed of white polyethylene plastic
- Cutting board removable for cleaning
- Two epoxy-coated steel wire shelves per door section standard
- Twelve (12) 1/6 4" deep pans constructed of polycarbonate plastic

OPTIONS & ACCESSORIES

- Stainless steel back
- Stainless steel interior
- Door lock
- Overshelves (single or double)
- Crumb catcher kit
- Richlite cutting board
- Night cover
- Epoxy coated shelves
- Shelf clips
- Shelf dividers
- Bottle organizer
- Bun rack
- Pan supports
- Pan support crossbar
- Pan configuration
- 6" legs or 3" casters
- Low profile casters
- Remote option* (see note on back page)

REFRIGERATION SYSTEM

- Uses environmentally friendly, energy efficient R290 refrigerant, and meets all regulatory requirements for CARB, SNAP, DOE & more
- Adaptive defrost
- Epoxy coated evaporator coil
- Maintains product temperatures between 36° - 38°F



Please verify qualifying units by visiting:
www.energystar.gov/cfs

3779 Champion Blvd., Winston-Salem, NC 27105
1-888-845-9800 Fax: 1-336-245-6453
Beverage-Air.com Sales@bevair.com



BEVERAGE-AIR

MODEL	SPE48HC-12M
EXTERNAL DIMENSIONAL DATA	
Width Overall	48"
Depth Overall	38 ³ / ₈ "
Height Overall with Casters	49"
Number Doors	2
Depth with Door Open 90°	52 ¹ / ₄ "
Door Opening	19 ⁵ / ₈ " x 21 ⁵ / ₈ "
Width, Cutting Board	10"
INTERNAL DIMENSIONAL DATA	
NET Capacity (cubic ft.)	13.01
Internal Width Overall (in)	44"
Internal Depth Overall (in)	15 ³ / ₈ "
Internal Height Usable (in)	23"
No. of Shelves	4
No. of Pans	12
ELECTRICAL DATA	
Full Load Amperes	2.0
REFRIGERATION DATA	
Horsepower	1/6
Capacity (BTU/Hr)	1094
SHIPPING DATA	
Gross Weight - Crated	336 lbs
Height - Crated	48"
Width - Crated	51"
Depth - Crated	38"

*NOTE: Remote units are field wired and come with 6" legs. Refrigerant must be specified at time of order.

Food Preparation Table - Mega Top

Model: SPE48HC-12M

Model Views

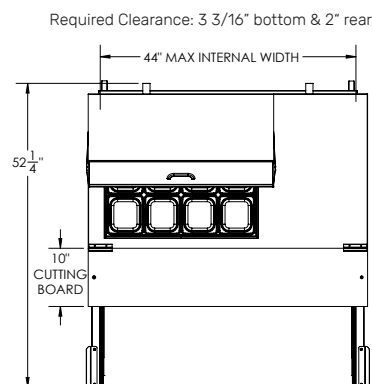

PLAN VIEW

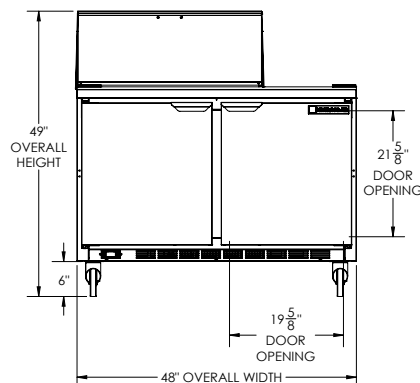

ELEVATION VIEW

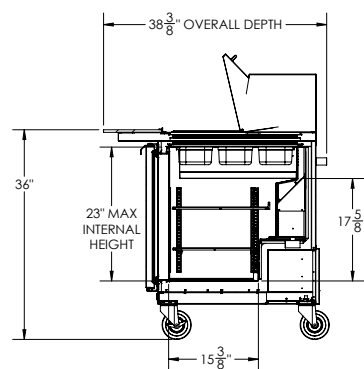

SIDE VIEW

*ELECTRICAL CONNECTION



115/60/1
NEMA 5-15P

Unit pre-wired at factory and include 8' long cord and plug set.



3779 Champion Blvd., Winston-Salem, NC 27105 1-888-845-9800 Fax: 1-336-245-6453 Beverage-Air.com Sales@bevair.com

an Ali Group Company



The Spirit of Excellence