

500-1DN 500-2DN 500-3DN

DRAWER WARMERS



• HALO HEAT . . . a controlled, uniform heat source that gently surrounds foods for better appearance, taste, and longer holding life.

- Product moisture is retained without adding water.
- Holding temperature gauge monitors inside air temperature.
- Dual wattage control on the one and two drawer 120V cabinets for more precise control of hard-to-hold products.
 - 500 watts for breads, rolls, biscuits
 - 1000 watts for meat, potatoes, and vegetables
- Extra large pans for additional capacity.
- Canted thermostat knob and indicator light.
 - Protects controls from damage
 - User safety feature
- ON/OFF adjustable thermostat.
- Can be built into cabinets or counters. Built-in trim kits are available.
- Stackable design.

Exterior of 20 gauge non-magnetic stainless steel with 16 gauge stainless steel drawer rail supports per drawer. Each cabinet is controlled by one (1) ON/OFF adjustable thermostat with a range of 60° to 200°F (16° to 93°C) and includes one (1) holding temperature gauge to monitor inside air temperature. Each drawer includes one (1) 12" x 20" x 6" (305mm x 508mm x 152mm) stainless steel pan. Drawer warmers are designed with four (4) stacking projections, located on the top of each cabinet, to allow stacking in any combination without the need of additional hardware. Stacked combinations can be mounted on a 3" (76mm) or 5" (127mm) Caster Stand Assembly for mobility, or a 6" (152mm) Leg Stand Assembly for stationary placement.

- MODEL 500-1DN: one drawer warmer, narrow design

- MODEL 500-2DN: two drawer warmer, narrow design

- MODEL 500-3DN: three drawer warmer, narrow design

ELECTRONIC CONTROL OPTION

- Solid state electronic control option simplifies temperature setting, has a clear, easy-to-read LED display, and is adjustable in increments of 1 degree.

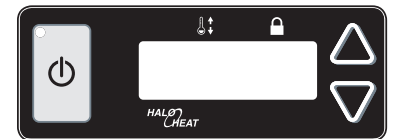

ADDITIONAL FEATURES

- Stack units without additional hardware
- Individual or stacked units can be mounted on:
 - 3" (76mm) casters and Caster Stand Assembly
 - 5" (127mm) casters and Caster Stand Assembly
 - 6" (152mm) Leg Stand Assembly



ANSI/NSF 4



W164 N9221 Water Street • P.O. Box 450 • Menomonee Falls, Wisconsin 53052-0450 • U.S.A.

PHONE: 262.251.3800 800.558.8744 U.S.A./CANADA FAX: 262.251.7067 800.329.8744 U.S.A. ONLY

www.alto-shaam.com





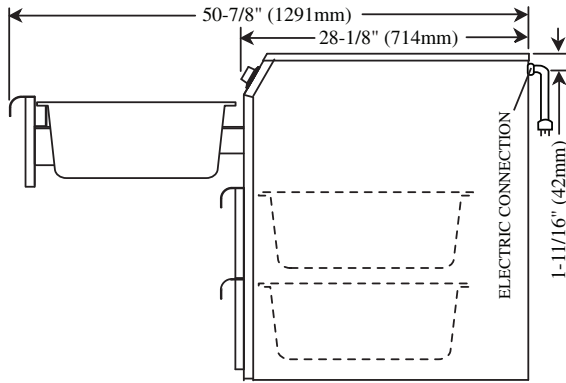

500-1DN, 500-2DN, 500-3DN

DRAWER WARMERS

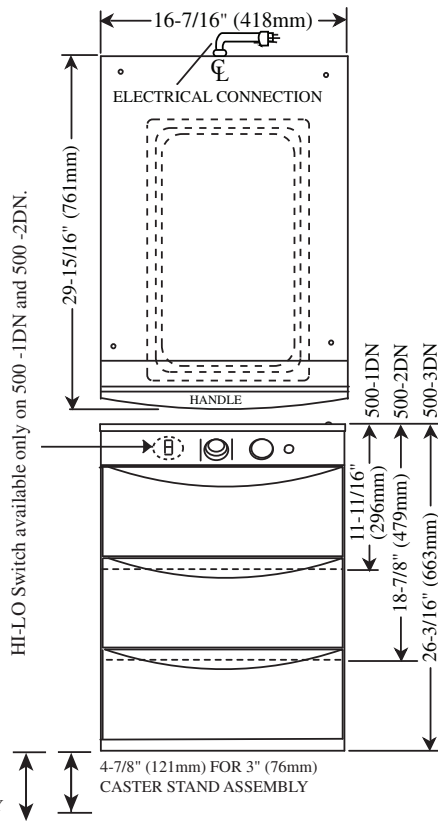

DIMENSIONS: H X W X D	
500-1DN EXTERIOR:	11-11/16" x 16-7/16" x 29-15/16" (296mm x 418mm x 761mm)
500-2DN EXTERIOR:	18-7/8" x 16-7/16" x 29-15/16" (479mm x 418mm x 761mm)
500-3DN EXTERIOR:	26-3/16" x 16-7/16" x 29-15/16" (663mm x 418mm x 761mm)
Pan size: (EACH DRAWER)	
12" x 20" x 6" (305mm x 508mm x 152mm) GN 1/1	
CUT OUT DIMENSIONS: (FOR UNITS WITH BUILT-IN TRIM)	
Add 3/4" (19mm) to unit height and 1-1/2" (38mm) to unit width	



ELECTRICAL						
VOLTAGE	PHASE	CYCLE/HZ	AMPS	kW	CORD & PLUG	
120	1	60 LOW	4.0	0.5		NEMA 5-15P 15A, 125V PLUG
		60 HIGH	8.5	1.05		
208-240 at 208	1	50/60	4.0	0.8		NEMA 6-15P 15A, 250V PLUG FOR USA ONLY
		50/60	4.5	1.05		
230	1	50/60	4.2	0.97		CEE 7/7 220-230V PLUG

PRODUCT CAPACITY
20 lbs (9 kg) MAXIMUM • EACH DRAWER (34 BAKED POTATOES, 50 DINNER ROLLS)

WEIGHT			
	500-1DN	500-2DN	500-3DN
NET	67 lb (30 kg)	100 lb (45 kg) EST.	130 lb (59 kg) EST.
SHIP	75 lb (34 kg)	112 lb (51 kg)	145 lb (66 kg)
CARTON DIMENSIONS: (L x W x H)			
	33" x 21" x 15" (838mm x 533mm x 381mm)	33" x 21" x 22" (838mm x 533mm x 559mm)	33" x 21" x 29" (838mm x 533mm x 737mm)

INSTALLATION REQUIREMENTS
Drawer warmer must be installed level, and must not be installed in any area where it may be affected by steam, grease, dripping water, high temperatures, or any other severely adverse conditions.

CLEARANCE REQUIREMENT
3" (76mm) at the back, 2" (51mm) at the top, and 1" (25mm) at both sides. On-site venting for proper airflow must also be provided for built-in counter installations.

OPTIONS & ACCESSORIES	
Built-in Trim Kit	
<input type="checkbox"/> 500-1DN	44225
<input type="checkbox"/> 500-2DN	44227
<input type="checkbox"/> 500-3DN	44229
<input type="checkbox"/> Anti-Tip Kit	5007514

<input type="checkbox"/> Caster Stand Assembly w/ 5" (127mm) casters	55534
<input type="checkbox"/> Caster Stand Assembly w/ 3" (76mm) casters	5010921
<input type="checkbox"/> Drawer Assembly with vents	55537
<input type="checkbox"/> Leg Stand Assembly	55535
<input type="checkbox"/> Perforated pan grid, 12" x 20" (305mm x 508mm)	16642