

HOBART701 S Ridge Avenue, Troy, OH 45374
1-888-4HOBART • www.hobartcorp.com**FP100
FOOD PROCESSOR****HOBART****STANDARD FEATURES**

- Red OFF, Green ON Button
- Compact Design
- Angled Front
- Planetary Drive
- Large Half Size Feed Hopper
- All Aluminum Hopper and Housing
- Interlock Switch
- Plate Speed of 396 RPMs

OPTIONS

- Maximum Security Correctional Package

ACCESSORIES

- 3-Pack Plates: $\frac{1}{16}$, $\frac{5}{32}$ slicer plates, $\frac{3}{16}$ shredder plate, 1 wall rack
- 6-Pack Plates: $\frac{1}{16}$, $\frac{5}{32}$, $\frac{3}{8}$, $\frac{7}{32}$ slicer plates, $\frac{3}{16}$ shredder plate and $\frac{3}{8}$ dicer plate, 2 wall racks
- 3-Peg Wall Rack: designed to hold three plates for additional plate storage
- Slicer Plates: $\frac{1}{16}$, $\frac{5}{32}$, $\frac{7}{32}$, $\frac{3}{8}$, $\frac{5}{8}$ * and $\frac{3}{8}$ HD, $\frac{1}{2}$; $\frac{3}{16}$ crimping plate; soft dice $\frac{5}{16}$, $\frac{3}{8}$, $\frac{1}{2}$, $\frac{5}{8}$
- Julienne Plates: $\frac{3}{32}$, $\frac{3}{16}$, $\frac{5}{16}$
- Dicer Grids: $\frac{9}{32}$, $\frac{3}{8}$, $\frac{1}{2}$, $\frac{5}{8}$, $\frac{3}{4}$ *; soft dice $\frac{5}{16}$, $\frac{3}{8}$, $\frac{1}{2}$, $\frac{5}{8}$

*NOTE: When you use $\frac{5}{8}$ slicing plate for dicing, only a DICE-3/4 or 15DICE-5/8L dicer plate can be used.

- Shredder Plates: $\frac{1}{16}$, $\frac{3}{32}$, $\frac{1}{8}$, $\frac{3}{16}$, $\frac{5}{16}$, $\frac{7}{32}$
- Grater Plate: Fine, Extra Fine
- Machine Table: Adjustable height to hold Food Processor
- Adjustable height stainless steel lug cart
- Stainless steel receiving pan
- Plastic receiving pan

MODELS

- FP100 Continuous Feed Half Hopper Food Processor

Specifications, Details and Dimensions on Inside and Back.

**FP100 FOOD PROCESSOR**

FP100 FOOD PROCESSOR



701 S Ridge Avenue, Troy, OH 45374
1-888-4HOBART • www.hobartcorp.com

SOLUTIONS/BENEFITS

Red OFF, Green ON Button

Ease of operation

Compact Design

Ease of use, small footprint, reduced labor, increased sanitation and productivity

- Occupies minimal counter space
- Unit and receiving pan fit on 23" deep counter
- Plates remove in seconds
- Feed hopper removes without tools for ease of cleaning
- Produces consistent quality product results in seconds
- Production capability for 11 lbs. per minute

Angled Front

Operator convenience, ease of use

- 50° angle for ease of product loading
- Helps to reduce operator fatigue

Planetary Drive

Performance, reliability

- Helps to prevent stalling under heavy loads
- No rest times required between loads

Large Full Size Feed Hopper

Flexibility, convenience, reduced labor

- Supports processing capabilities for large variety of products
- Design permits continuous cutting of long products
- Eliminates precutting

All Aluminum Hopper and Housing

Durability, sanitation

- Anodized finish resists harsh cleaners
- Easy clean up

Interlock Switch

Protection

- Prevents machine from running when pusher plate swings away or is open

Plate Speed of 396 RPMs

Product quality and consistency

- Precise cutting and dicing action without bruising or mashing of products



701 S Ridge Avenue, Troy, OH 45374
1-888-4HOBART • www.hobartcorp.com

FP100 FOOD PROCESSOR

SPECIFICATIONS

DESIGN: Compact, conveniently designed at 50° angle for operator convenience. Small base occupies minimal counter space. Carrying handle on back of housing designed for ease of moving unit. Housing constructed of anodized aluminum with rubber feet on base to prevent movement or skidding. Removable feed hopper is burnished aluminum. Feed hopper, pusher and deflector plate of acetal thermoplastic.

ELECTRICAL: 120/60/1, 3 Conductor power cord (18 AWG) is 8 feet in length.

MOTOR: 3.5 amps. Planetary gear driven operating at 396 RPM output. 1/3 H.P. with overload protection.

SWITCHES: Easy to operate (red) OFF and (green) ON switch. Pusher plate and feed hopper interlocks.

STANDARD EQUIPMENT: Basic unit with deflector plate and cleaning brush.

WARRANTY: Unit has full one-year warranty on parts, labor and mileage against manufacturer's defects. Service contracts are available.

CUTTING TOOLS: Slicer, julienne and dicer plates feature cast aluminum plates with cutlery-grade stainless steel knives. Shredder and grater plates feature stainless steel cutting plates with acetal thermoplastic support hubs.

WEIGHT: Net - 39 lbs. Approximate Shipping - 46 lbs.

FP100 FOOD PROCESSOR



701 S Ridge Avenue, Troy, OH 45374
1-888-4HOBART • www.hobartcorp.com

DETAILS AND DIMENSIONS

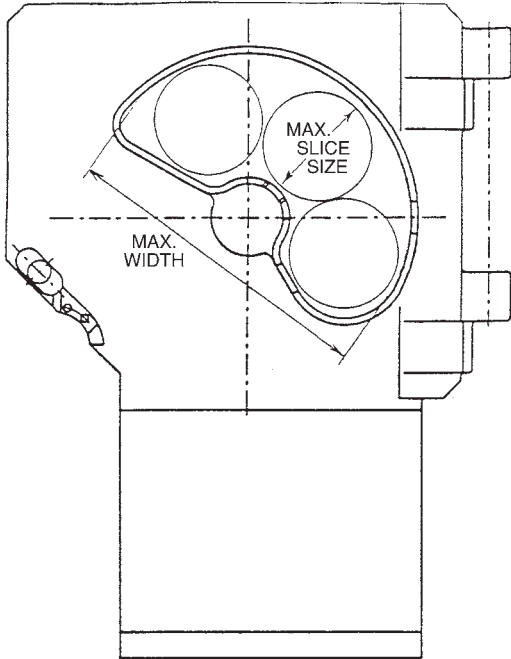

FP100	
Hopper Maximum Width	6 $\frac{3}{8}$ "
Maximum Slice Size	2 $\frac{1}{2}$ "
Usable Depth	6"
Feed Tube Diameter	2 $\frac{1}{8}$ "

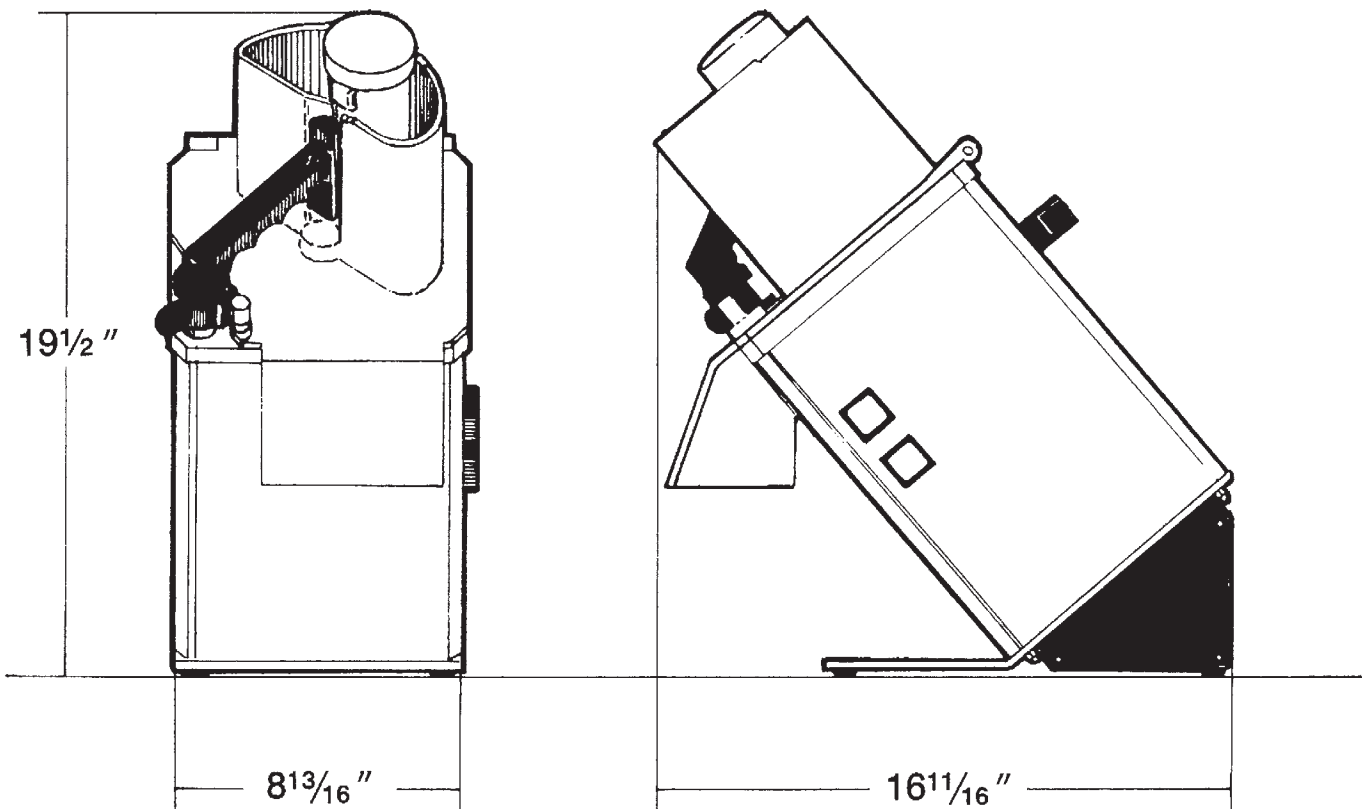

As continued product improvement is a policy of Hobart, specifications are subject to change without notice.