



JOB:  
ITEM:  
QTY:



## PRODUCE/STOCKING CART

### APPLICATION:

These all welded aluminum carts provide maximum strength and durability. The solid top carts have a marine edge to help contain spills. The T-Bar top carts provide air circulation.

### MATERIAL:

Framework is constructed of 1 1/4"x1 1/4"x.070" wall tubing. Solid shelves are constructed with .080" aluminum sheet with raised marine edge. T-Bar shelves are constructed using 1 1/4"x2 1/4"x.100" wall T-Bar. Legs and handles are constructed out of 1 5/16" diameter pipe.

### CASTERS:

These carts come equipped with 5" platform type casters.

### GUARANTEE:

These carts carry a **Lifetime Guarantee** against rust and corrosion and also carry a **Five-Year Guarantee** against workmanship and material defects.



**Model #1415**



**Model #1420**



**Model #1490**



Phone:800-255-0104  
Fax: 877-877-7687  
[www.newageindustrial.com](http://www.newageindustrial.com)  
[sales@newageindustrial.com](mailto:sales@newageindustrial.com)

New Age Industrial reserves the right to modify or make changes at any time without notice to materials and specifications.

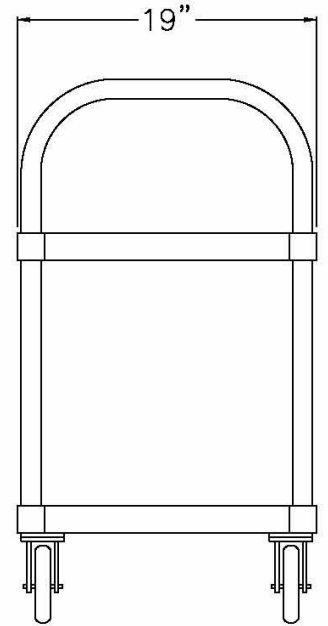
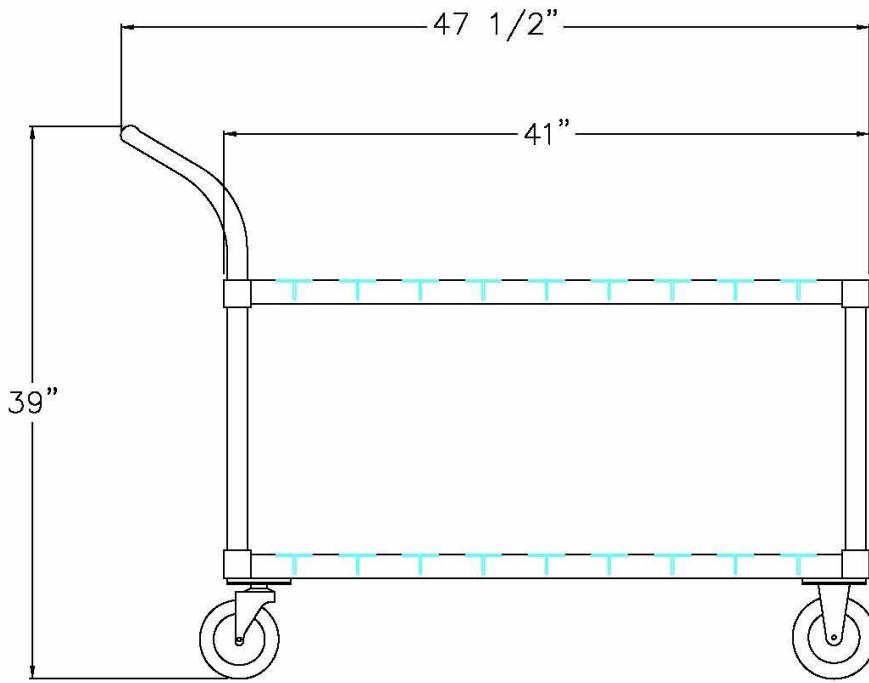

**Model #1420**

Model No.	Size-W	Size-H	Size-D	Wt. Cap.	No. Casters
<b>Solid Top Shelf - T-Bar Bottom Shelf</b>					
1415	19"	30"	41"	800#	4
<b>Solid Top Shelf - T-Bar Bottom Shelf W/Handle</b>					
1416	19"	39"	47 1/2"	800#	4
<b>T-Bar Top &amp; Bottom Shelf W/Handle</b>					
1420	19"	39"	47 1/2"	800#	4
<b>Solid Top &amp; Bottom Shelf W/Handle</b>					
1490	19"	39"	47 1/2"	800#	6



Phone: 800-255-0104  
 Fax: 877-877-7687  
[www.newageindustrial.com](http://www.newageindustrial.com)  
[sales@newageindustrial.com](mailto:sales@newageindustrial.com)

New Age Industrial reserves the right to modify or make changes at any time without notice to materials and specifications.