

Job: _____

Item: _____

Quantity: _____

Bun Pan Dollies

Stores Up To 75 Bun Pans!

- **Ideal dolly for transporting and storing bun pans.**
- Heavy duty, all welded aluminum dollies are indispensable for any bakery or food preparation area.
- Handles and side supports of 1" square tube with rounded corners ensures the strength and rigidity of the frame and is easy on the hands of the operator.

Easy to Maneuver

- Equipped with four 5" platform type heavy duty swivel casters, these all welded aluminum dollies are built to be loaded up.
- Secure, heavy duty caster assembly bolts casters tightly into place, yet allows for easy replacement or upgrade.

Sanitary

- Each unit is all welded with all seams fully welded and sealed providing a smooth, easy to clean surface.
- No cracks or crevices to trap dirt!

Guaranteed

- **Lifetime Guarantee** against rust and corrosion.
- **Five-Year Guarantee** against material defects and workmanship.

NSF Certified.



#1192



#1193



#1194

This information is for general sales and engineering use only. New Age Industrial reserves the right to modify or make changes at any time without notice to materials and specifications.



Distributed by:

Job: _____

Item: _____

Quantity: _____

Bun Pan Dollies

MATERIAL:

- Framework is constructed of 2" x 2" x .125" wall angle.

Models #1193 and #1194:

- Handles and sides are constructed of 1" x 1" x .070" wall tubing.

CASTERS:

- Equipped with four 5" platform type swivel casters.

GUARANTEE:

- Lifetime Guarantee against rust and corrosion.
- Five-Year Guarantee against workmanship and material defects.

NSF CERTIFIED



Model No.	Size W-H-D	Wt. Cap.	Ship Wt.
ANGLE DOLLY WITHOUT SIDES OR HANDLE			
1192	18 7/8" x 7" x 27"	800#	20#
ANGLE DOLLY WITH SIDES & HANDLE			
1193	21" x 33 1/2" x 28 1/2"	1000#	22#
TWO TIER ANGLE DOLLY WITH SIDES & HANDLE			
1194	21" x 44-1/2" x 30"	1200#	29#

Four 5" platform type swivel casters (#C453).

Options:

- Caster Locks (2)**
- Medical Caster Upgrade**
- Prison Package - Tamper-Proof Screws**

ALUMINUM DRAG HOOK

1199	37-1/2" Long	1#
------	--------------	----

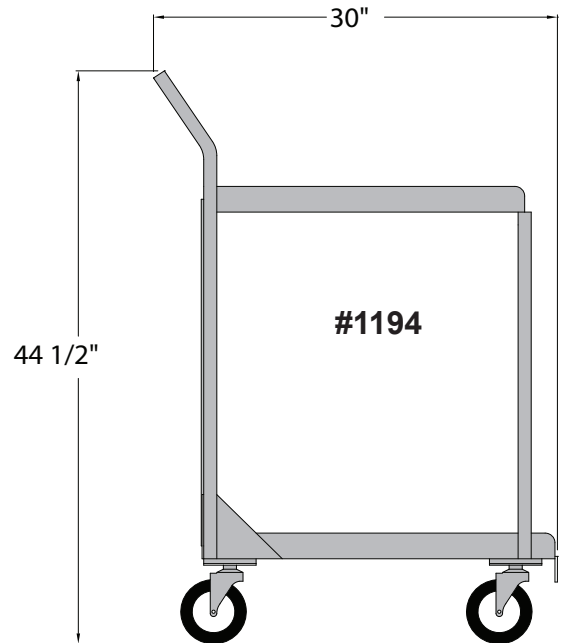
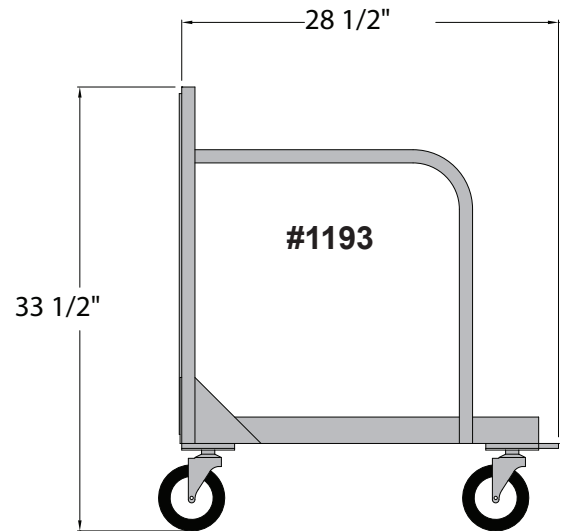

#1199

This information is for general sales and engineering use only. New Age Industrial reserves the right to modify or make changes at any time without notice to materials and specifications.



Distributed by: